

# FACTORYCAT®

Industrial Cleaning Equipment

# MAG-HID

29" - 34" Scrubbers



A COMPLETE FAMILY OF INDUSTRIAL CLEANING EQUIPMENT



# KEY FEATURES

# INDUSTRIES



**Machine Control Panel** uses off-the-shelf toggle and marine duty switches and features universal icons which simplifies training.



**Vacuum Muffler** allows machine to consistently achieve as low as 62 dB while thoroughly drying the floor.



**Squeegee Adjustments made simple** with quick change squeegee latch allows toolless maintenance and 4-sided squeegee blade.

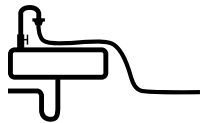

**Front Fill System** features a retractable hose for easy filling on standard sink-faucets and a stainless screen for bucket filling.



**Oversized Vacuum Screen Shut-Off** quickly arrests overflow issues to protect the Vacuum Motor.

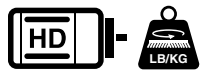

**High Performance motors and down pressure** provides an unmatched standard of cleaning.



- Fabrication Shops
- Machine Shops
- Aviation
- Beverage Distribution
- Warehouses
- Automotive Shops
- Food Packaging
- Sports Arenas

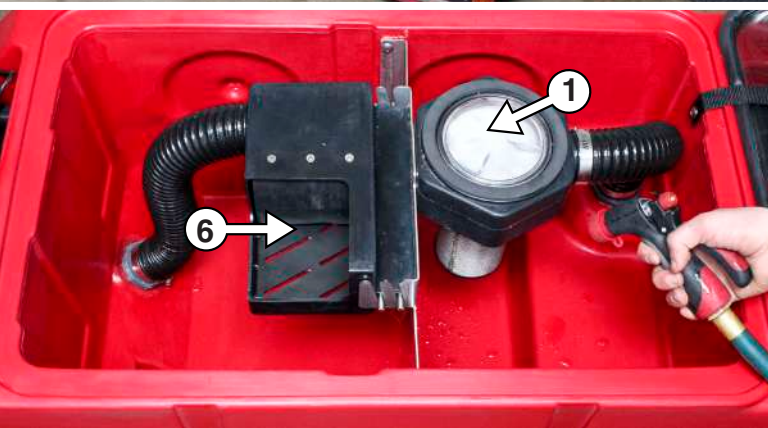
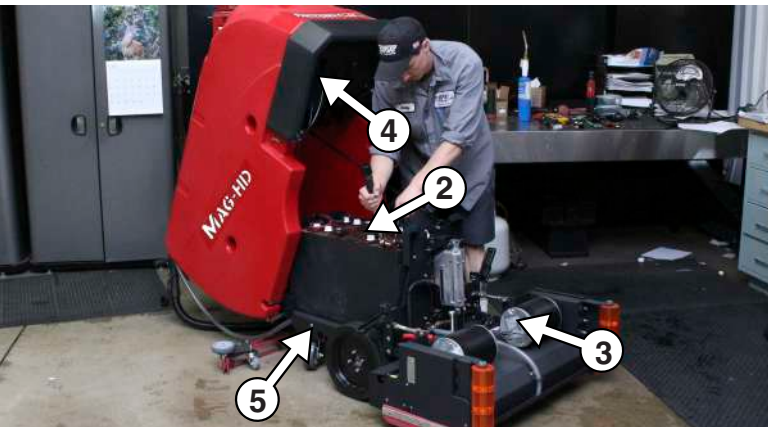

## TANK TIPS FOR ACCESS

- 1 Vacuum Screen & Filter Cleaning
- 2 Service Batteries
- 3 Inspect Scrub Motors
- 4 Inspect Vacuum Motor
- 5 Inline Solution Filter
- 6 Drain Saver

Reduce costly repairs associated with clogged floor drains with our Drain Saver Basket.



# VIEW INSIDE

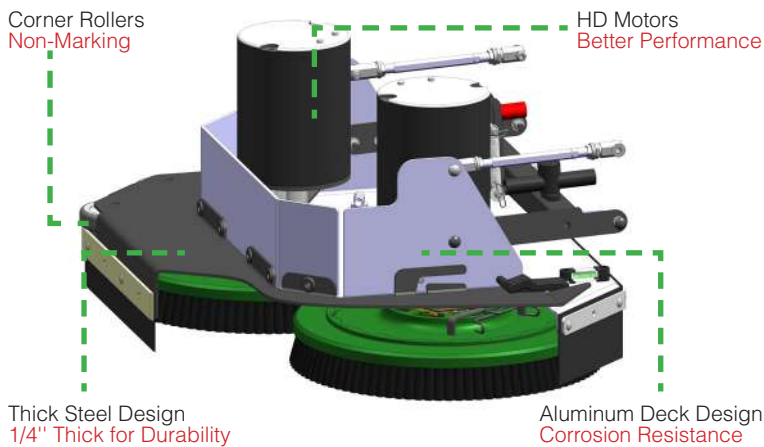
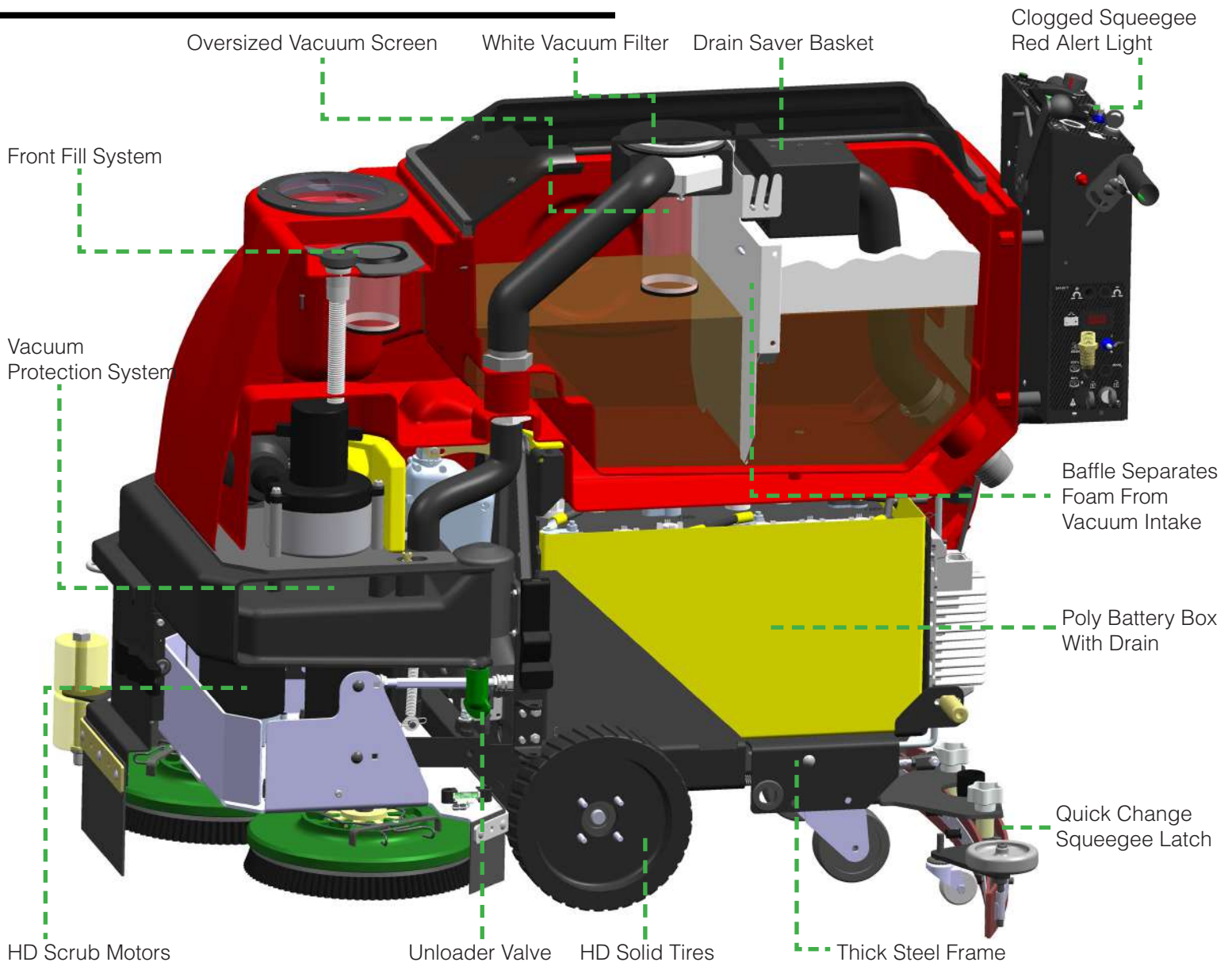

## Disk Benefits

- Brush / Pad Selection
- Lowest Maintenance Cost
- Gimballled Drivers Improves Cleaning On Irregular Floors
- Brushes Individually Driven For Unmatched Performance

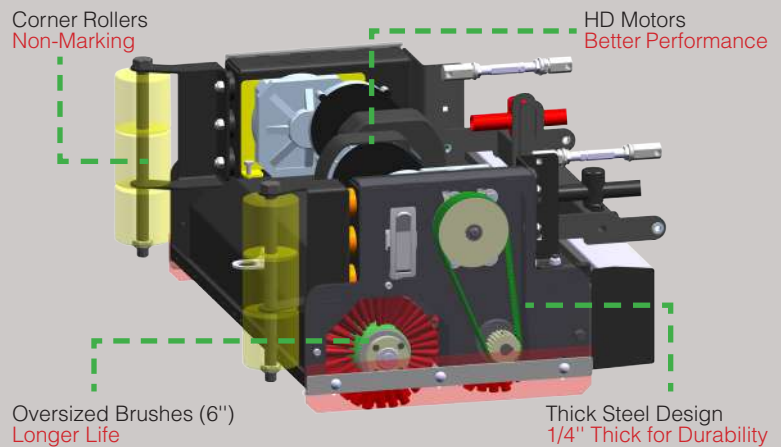

## Cylindrical Benefits

- Eliminates Dust Mopping
- Scrub & Sweep Simultaneously
- Superior Expansion Joint Cleaning

# CALL FOR A DEMONSTRATION



☎ **800-634-4060**  
 🌐 **(+001)-262-681-3583**  
 🌐 **www.factorycat.com**

Since 1986, our family owned company has been designing, building and supporting the best in floor maintenance equipment. Our **FACTORYCAT** brand services the world with unsurpassed industrial cleaning equipment, continually exceeding expectations and setting the industry bar that much higher.

We've built our reputation by providing the highest value machines and providing local support via 425 distributors in over 42 different countries.

**AUTHORIZED DISTRIBUTOR**



## BODY CONSTRUCTION / DIMENSIONS

Tank Material:	Poly 3/8" (9.5 mm)
Chassis Construction:	3/16" Steel (4.8 mm) Powder Coated Steel
Front Wheels (Diameter x Width):	(2x) 12" x 2.75" ([2x] 30.5 x 7 cm) - Solid Black
Rear Casters (Diameter x Width):	(2x) 5" x 2" ([2x] 12.7 x 5.1 cm) - Non-Marking Grey
Size (L x W x H):	55" x 26" x 40" (139.7 x 66 x 101.6 cm)
Weight (w/o Batteries):	441 - 481 lbs (200 - 218 kg)
Weight (w/ 315 ah Batteries):	775 - 825 lbs (352 - 374 kg)

## BRUSH / PAD SYSTEM

Disk Dimensions:	30" - (2x) 15" Diameter (76.2 - [2x] 38.1 cm)
<small>Includes Jaws with Rollers for Wall Protection</small>	34" - (2x) 17" Diameter (86.4 - [2x] 43.2 cm)
Disk Motor:	(2x) 1.0 hp ([2x] 746 watts)
Disk Brush Speed:	350 rpm
Cylindrical Dimensions:	29" - (2x) 6" x 27" (73.7 - [2x] 15.2 x 68.6 cm)
<small>6" Diameter Brush</small>	33" - (2x) 6" x 31" (83.8 - [2x] 15.2 x 78.7 cm)
Cylindrical Motor:	(2x) 1.0 hp / 350 rpm ([2x] 746 watts)
Cylindrical Brush Speed:	750 rpm
Brush Pressure Settings:	(5) with Auto Adjust
Brush Down Pressure:	Up to 185 lbs (84 kg) / 500 lbs (227 kg) Actuator Rating

## POWER SYSTEM

System Voltage:	24 VDC
Standard Battery:	315 ah WET
Optional Battery:	360 ah WET / 335 ah AGM*
<small>*Includes Onboard Charger</small>	
Run Time:	Up to 5.0 Hours**
<small>**Run times are based on continuous scrubbing run times.</small>	
Charger:	120VAC / 60 Hz Input - 24VDC / 30 amp Output

## DRIVE SYSTEM

Power:	0.75hp - All Gear / Sealed (559 watts)
Forward Speed:	0 - 290 ft/min / 0 - 3.3 mph (0 - 88 m/min / 0 - 5 km/h)
Scrubbing Speed:	0 - 229 ft/min / 0 - 2.6 mph (0 - 70 m/min / 0 - 4 km/h)
Reverse Speed:	0 - 202 ft/min / 0 - 2.3 mph (0 - 62 m/min / 0 - 4 km/h)

## SOLUTION / RECOVERY SYSTEMS

XL Tank Solution Capacity:	35 Gallons (132.5 liters) - w/ Graduated Site Tube
Solution Flow / Filter:	0 - 1.0 GPM / Stainless Inline (0 - 4 LPM)
XL Tank Recovery Capacity:	37 Gallons (140.1 liters) - 1.5" diameter Drain Hose
Optional Small Tank Capacity:	30 Gal (113.6 liters) Solution / 32 Gal (121.1 liters) Recovery
Demisting Chamber:	1.25 Gallons (4.7 liters)
Drain Saver:	30 cubic inches (492 cubic cm)
Vacuum Power:	0.8 hp / 3 Stage (640 watts)
Vacuum Specs (Water Lift / Airflow):	68" / 72 cfm (173 cm / 2 cm/m)
Squeegee:	Curved w/ 4-sided Rear Blade & Quick Change Latch All Sizes - 42" (106.7 cm) Optional - 33", 36", & 39" (83.8, 91.4, 99.1 cm)

## GENERAL

Cleaning Width:	30" & 34" - Disk (76.2 & 86.4 cm) 29" & 33" - Cylindrical (73.7, 83.8 cm)
Productivity - Theoretical:	Up to 31,915 sqft (2,965 sqm)***
<small>***Productivity is based off of ISSA 2010 Cleaning Times</small>	
Productivity - Practical:	Up to 14,851 sqft (1,380 sqm)***
<small>***Productivity is based off of ISSA 2010 Cleaning Times</small>	



**Manufactured By**  
 R.P.S. Corporation  
 1711 South Street  
 Racine, Wisconsin 53404 (USA)  
 Phone: (800) 634-4060  
 International: (+001) 262-681-3583  
 www.factorycat.com