

FACTORYCAT®

Industrial Cleaning Equipment

MINI-HID

25" - 29" Scrubbers



A COMPLETE FAMILY OF INDUSTRIAL CLEANING EQUIPMENT

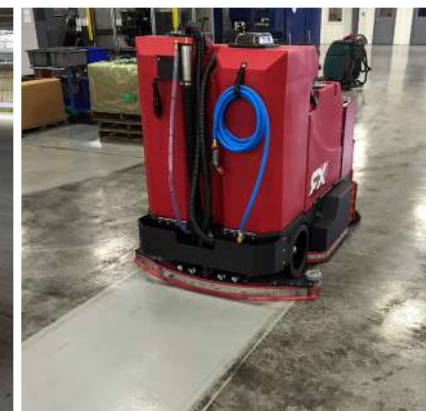

KEY FEATURES

INDUSTRIES



Machine Control Panel uses off-the-shelf toggle and marine duty switches and features universal icons which simplifies training.



Vacuum Muffler allows machine to consistently achieve as low as 62 dB while thoroughly drying the floor.



Squeegee Adjustments made simple with quick change squeegee latch allows toolless maintenance and 4-sided squeegee blade.

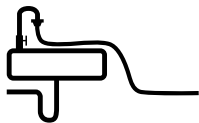

Front Fill System features a retractable hose for easy filling on standard sink-faucets and a stainless screen for bucket filling.



Oversized Vacuum Screen Shut-Off quickly arrests overflow issues to protect the Vacuum Motor.

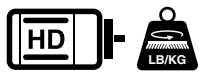

High Performance motors and down pressure provides an unmatched standard of cleaning.



- Fabrication Shops
- Machine Shops
- Aviation
- Beverage Distribution
- Warehouses
- Automotive Shops
- Food Packaging
- Sports Arenas

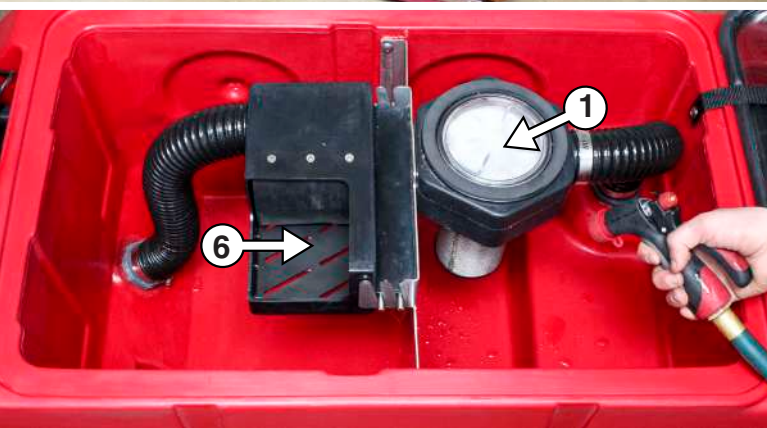
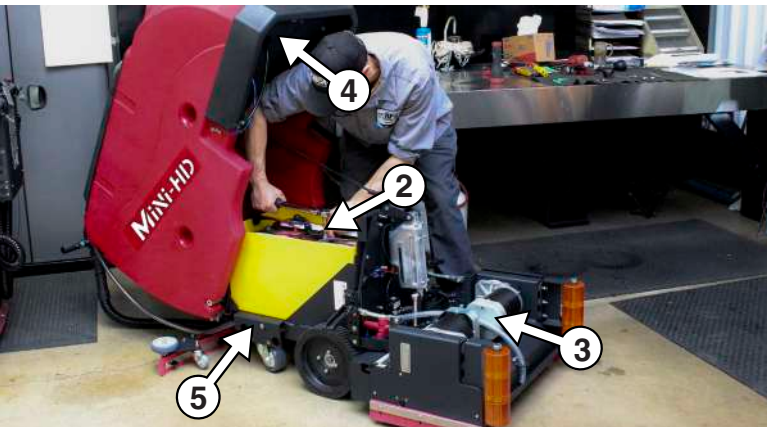

TANK TIPS FOR ACCESS

- 1 Vacuum Screen & Filter Cleaning
- 2 Service Batteries
- 3 Inspect Scrub Motors
- 4 Inspect Vacuum Motor
- 5 Inline Solution Filter
- 6 Drain Saver

Reduce costly repairs associated with clogged floor drains with our Drain Saver Basket.



VIEW INSIDE

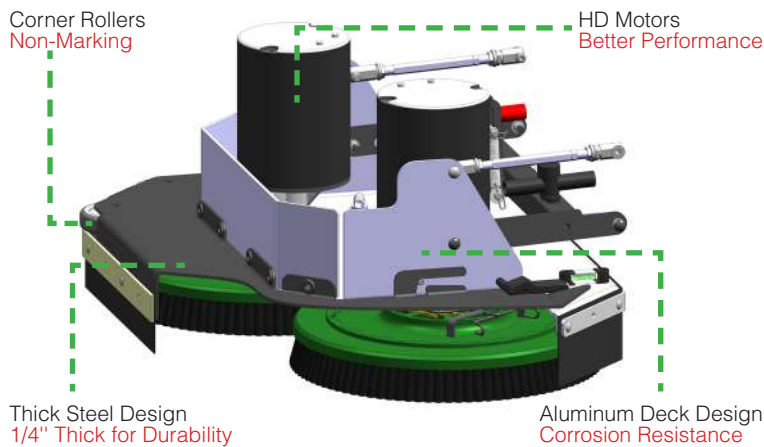
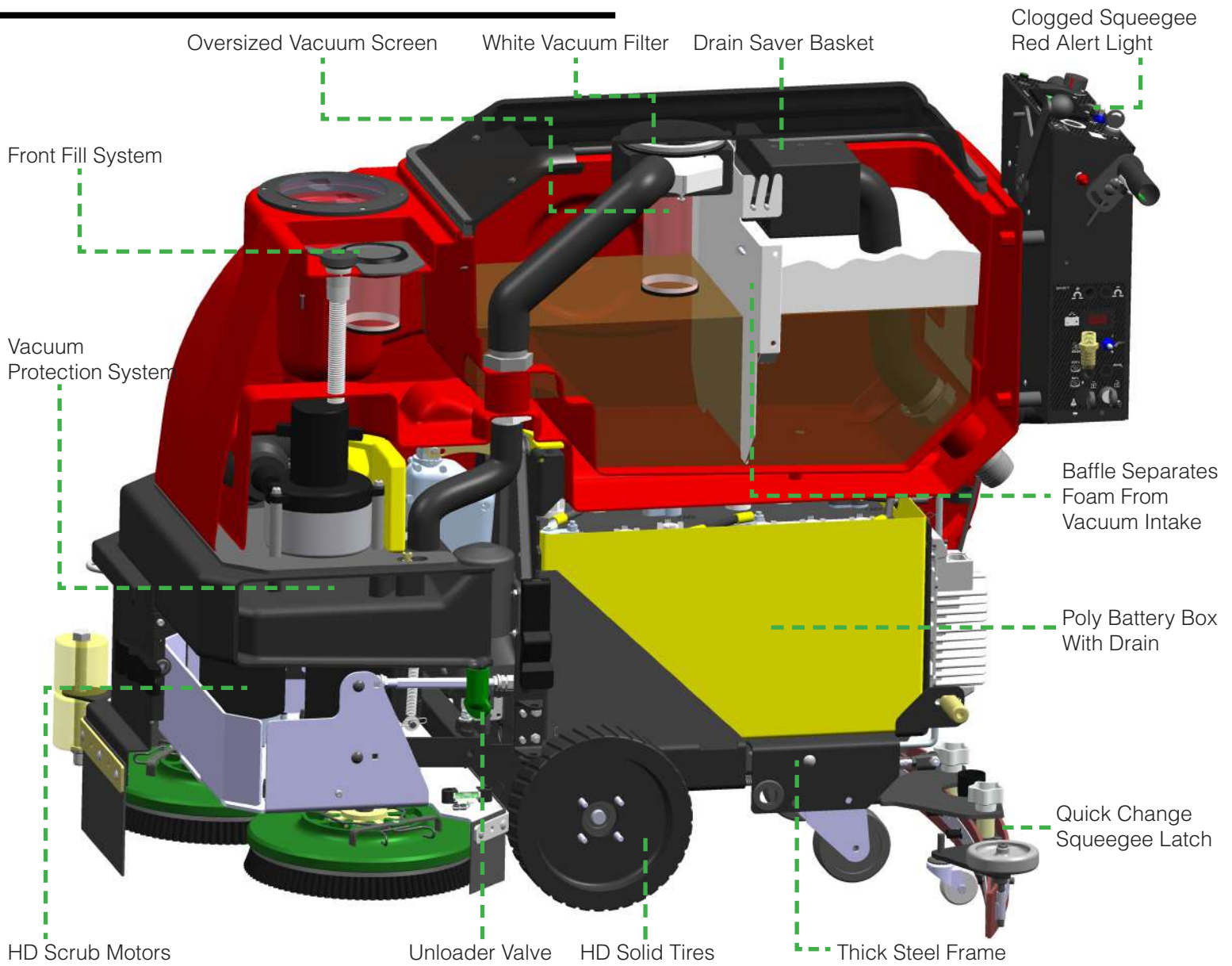

Disk Benefits

- Brush / Pad Selection
- Lowest Maintenance Cost
- Gimballled Drivers Improves Cleaning On Irregular Floors
- Brushes Individually Driven For Unmatched Performance

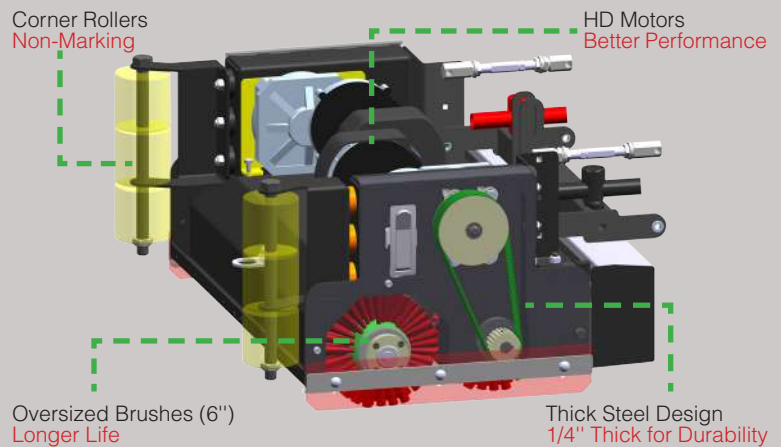

Cylindrical Benefits

- Eliminates Dust Mopping
- Scrub & Sweep Simultaneously
- Superior Expansion Joint Cleaning

CALL FOR A DEMONSTRATION



☎ **800-634-4060**
 🌐 **(+001)-262-681-3583**
 🌐 **www.factorycat.com**

Since 1986, our family owned company has been designing, building and supporting the best in floor maintenance equipment. Our **FACTORYCAT** brand services the world with unsurpassed industrial cleaning equipment, continually exceeding expectations and setting the industry bar that much higher.

We've built our reputation by providing the highest value machines and providing local support via 425 distributors in over 42 different countries.

AUTHORIZED DISTRIBUTOR

BODY CONSTRUCTION / DIMENSIONS

Tank Material:	Poly 3/8" (9.5 mm)
Chassis Construction:	3/16" (4.8 mm) Powder Coated Steel
Front Wheels (Diameter x Width):	(2x) 10" x 2.5" ([2x] 25.4 x 6.4 cm) - Solid Black
Rear Casters (Diameter x Width):	(2x) 4" x 2" ([2x] 10.2 x 5.1 cm) - Non-Marking Grey
Size (L x W x H):	52" x 22" x 40" (132.1 x 55.9 x 101.6 cm)
Weight (w/o Batteries):	393 - 443 lbs (178 - 201 kg)
Weight (w/ 210 ah Batteries):	625 - 675 lbs (284 - 306 kg)

BRUSH / PAD SYSTEM

Disk Dimensions:	26" - (2x) 13" Diameter (66 - [2x] 33 cm)
<small>Includes Jaws with Rollers for Wall Protection</small>	28" - (2x) 14" Diameter (71.1 - [2x] 35.6 cm)
Disk Motor:	(2x) 0.75 hp / 270 rpm ([2x] 559 watts)
Optional Motor Upgrade:	(2x) 1.0 hp / 350 rpm ([2x] 746 watts)
Disk Brush Speed:	270 rpm or 350 rpm
Cylindrical Dimensions:	25" - (2x) 6" x 23" (63.5 - [2x] 15.2 x 58.4 cm)
<small>6" Diameter Brush</small>	29" - (2x) 6" x 27" (73.7 - [2x] 15.2 x 68.6 cm)
Cylindrical Motor:	25" - (2x) 0.75 hp / 350 rpm ([2x] 559 watts)
	29" - (2x) 1.0 hp / 350 rpm ([2x] 746 watts)
Cylindrical Brush Speed:	750 rpm
Brush Pressure Settings:	(5) with Auto Adjust
Brush Down Pressure:	Up to 175 lbs (79 kg) / 500 lbs (227 kg) Actuator Rating

POWER SYSTEM

System Voltage:	24 VDC
Standard Battery:	210 ah WET
Optional Battery:	245 ah WET / 250 ah AGM*
<small>*Includes Onboard Charger</small>	
Run Time:	Up to 3.5 Hours**
<small>**Run times are based on continuous scrubbing run times.</small>	
Charger:	120VAC / 60 Hz Input - 24VDC / 25 amp Output

DRIVE SYSTEM

Power:	0.75hp - All Gear / Sealed (559 watts)
Forward Speed:	0 - 290 ft/min / 0 - 3.3 mph (0 - 88 m/min / 0 - 5 km/h)
Scrubbing Speed:	0 - 229 ft/min / 0 - 2.6 mph (0 - 70 m/min / 0 - 4 km/h)
Reverse Speed:	0 - 202 ft/min / 0 - 2.3 mph (0 - 62 m/min / 0 - 4 km/h)

SOLUTION / RECOVERY SYSTEMS

XL Tank Solution Capacity:	21 Gallons (79.5 liters) - w/ Graduated Site Tube
Solution Flow / Filter:	0 - 0.7 GPM / Stainless Inline (0 - 2 LPM)
XL Tank Recovery Capacity:	23 Gallons (87.1 liters) - 1.5" diameter Drain Hose
Optional Small Tank Capacity:	16 Gal (60.6 liters) Solution / 17 Gal (64.4 liters) Recovery
Demisting Chamber:	1.25 Gallons (4.7 liters)
Drain Saver:	30 cubic inches (492 cubic cm)
Vacuum Power:	0.8 hp / 3 Stage (640 watts)
Vacuum Specs (Water Lift / Airflow):	68" / 72 cfm (173 cm / 2 cm/m)
Squeegee:	Curved w/ 4-sided Rear Blade & Quick Change Latch 25C, 26D - 36" (91.4 cm) 28D, 29C - 39" (99.1 cm) Optional - 33" & 42" (83.8, 106.7 cm)

GENERAL

Cleaning Width:	26" & 28" - Disk (66 & 71.1 cm) 25" & 29" - Cylindrical (63.5 & 73.7 cm)
Productivity - Theoretical:	Up to 27,027 sqft (2,511 sqm)***
<small>***Productivity is based off of ISSA 2010 Cleaning Times</small>	
Productivity - Practical:	Up to 12,526 sqft (1,164 sqm)***
<small>***Productivity is based off of ISSA 2010 Cleaning Times</small>	



Manufactured By
 R.P.S. Corporation
 1711 South Street
 Racine, Wisconsin 53404 (USA)
 Phone: (800) 634-4060
 International: (+001) 262-681-3583
 www.factorycat.com