

# COMBiLiFT

LIFTING INNOVATION

## COMBi-WR

The first purpose built, pedestrian reach stacker combining innovative features and effortless operation.



Fork Lift Truck Association

Winner



COMBi-WR

[combilift.com](http://combilift.com)

REF.	DESCRIPTION	Std.	Optional	
1a	Max. Lift Height	118"	165"	192"
1b	Free Lift Height	35"	59"	73"
2	Height Mast Closed	83"	106"	120"
3	Max. (Mast Raised)	165"	213"	240"
4	Overall Length	77"		
5	Fork Travel	23"		
6	Ground Clearance Under Mast	3"		
7	Ground Clearance to Center of Wheelbase	2"		
8	Width	52"		
9	Outside Spread of Fork Arms	32"		
10	Track Front	46"		
11	Frame Opening	41½"		
12	Load Center Distance	24"		
13	Overhang Front	24"		
14	Wheelbase	46"		
15	Overhang Back	7"		
16	Fork Side Shift	3" Left / 3" Right		
17	Length from Face of Fork	34½"		
18	Fork Backward Tilt	3°		
19	Fork Forward Tilt	3°		
20	Minimum Outside Radius	53"		
21	Leg Height	5"		
22	Leg Length	21"		
A	Capacity	3,100 lbs @ 125" Lift		
B	Unladen Weight	5,000 lbs	5,700 lbs	5,950 lbs
C	Maximum Ground Speed	3¾ mph		
D	Gradeability	5%		
E	Battery Capacity	24 V / 270 Ah		
F	Fork Section	1½" x 4" x 42"		
G	Front Tire (Polyurethane)	OD 5" / Width 3"		
H	Rear Tire (Vulkollan)	OD 10" / Width 3"		
I	Standard Color	Yellow & Gray		
J	AC Electric Traction Motor	24V / 3.35 HP		
K	AC Electric Pump Motor	24V / 6.7 HP		

International Application No. PCT/EP2012/067238

## Superior safety with Combilift's patented Multi Position Tiller Arm

The tiller can be turned to the left or right to allow the operator to remain at the side. This enables full visibility of the load and forks, while maintaining full steering control, providing greater awareness of the surroundings for enhanced overall safety.

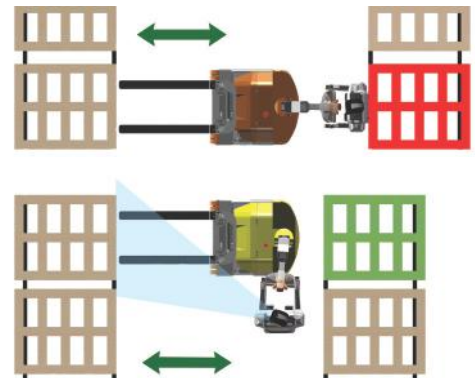
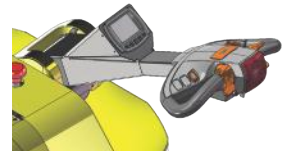

Standing to the side of the stacker eliminates the risk of being trapped or crushed whilst allowing the Combi-WR to operate in very narrow aisles.

### Features Include:

- Pantograph
- Power Steering
- AC Motor Technology
- 39" High Load Back Rest
- Rear Wheel Drive
- 3/3" Side Shift
- Patented Multi-Position Tiller Arm

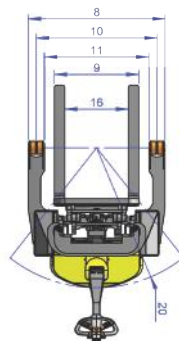
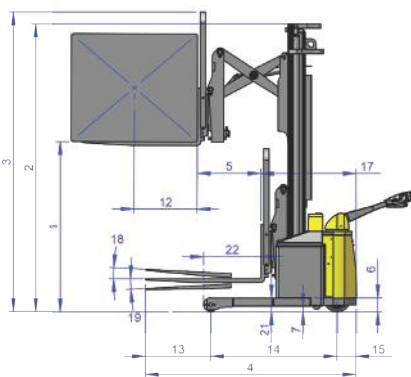

### Load Capacity:

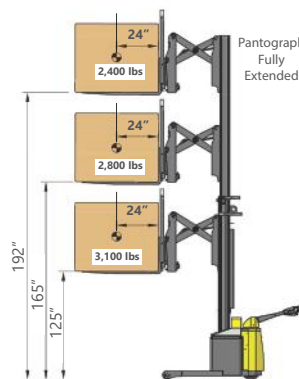

303 Concord Street  
Greensboro  
North Carolina 27406  
**Toll free: 1-877 COMBI 56**  
Tel: 336-378-8884  
info@combilift.com

Combilift has a policy of continuous product development and reserves the right to alter specifications without prior notice. Specifications and/or dimensions may vary from those illustrated in some countries.

# COMBI-WR

combilift.com