

# 80V ELECTRIC PNEUMATIC



4000 - 11000 LBS.

SPECIFICATIONS



8FBMK25-30T | 8FBM20-50T

CLASS  
**1**

ELECTRIC MOTOR RIDERS

[ToyotaForklift.com](http://ToyotaForklift.com)

## 80V ELECTRIC PNEUMATIC

### CAPACITY

4000 – 11000 LBS.

### WHEELBASE

62 – 80 IN.

### LOAD CENTER

24 IN.

### INDUSTRIES



Agriculture



Brick, Block  
& Pipe



Concrete



Distribution



Oil & Gas

## STANDARD FEATURES

### SUPPORT

- System of Active Stability™ (SAS)
  - Active control rear stabilizer
  - Active Mast Control
- Operator Presence Sensing System (OPSS)
- Key lowering interlock
- Electric horn
- Manual return to neutral

### PERFORMANCE

- AC drive system
- AC hydraulic lift system
- Wet disc brakes
- Three forms of energy regeneration
  - Coast control
  - Plug braking
  - Foot braking
- Digital (LCD) multifunction display
  - Time & date
  - Speedometer
  - Multifunction hour meter
  - Battery capacity indicator
  - Over-discharge warning (lift interrupt)
  - Parking brake indicator
- Low-speed-setting switch
- Direction indicator
- Maximum speed limiter
- Built-in analyzer
- Self-diagnostics
- Power select functions (S.P.H.)

### BODY/EXTERIOR DESIGN

- Wide-view 2-stage mast (V)
- Punched plate entry/exit step
- 48" load backrest extension
- Solid pneumatic tires
- Wide-view carriage bars
- Drawbar pin
- Adjustable front headlights
- ORS vinyl full-suspension seat
- Retractable non-cinching seat belt
- Wide-opening battery hood
- Bolt-on overhead guard
- Long forkbar option (see dealer for details)

### OPERABILITY & ERGONOMICS

- Strategically configured instrument display
- On-demand hydrostatic power steering
- Dual operator assist grips
- SAS automatic fork-leveling control
- Electric directional shift control
- 11.8"-dia. two-spoke steering wheel
- Seat-mounted mini-lever hydraulic controls
- Heavy-duty slip-resistant floor mat
- Dash-integrated pen/pencil holder
- Hood-integrated clipboard
- Dash-mounted cup holder
- Automatic parking brake

### SERVICEABILITY

- AC drive motor (no brushes or commutator)
- AC hydraulic motor (no brushes or commutator)
- Easy-access no-tools floorboard
- Battery compartment hood assist damper
- Planned maintenance indicator
- Easy-access controllers
- CAN-bus controller wiring

## OPTIONAL EQUIPMENT

### LOAD HANDLING

- Wide visible mast (V)
- Full free-lift 2-stage mast (FV)
- Full free-lift 2-cylinder 2-stage mast (FW)
- Full free-lift 3-stage mast (FSV)
- Full free-lift 4-cylinder 3-stage mast (FSW)
- Mast shipped separately (for masts with lowered height greater than 104")
- Fully oil-charged lift cylinders
- Cushioned lower near floor
- Tilt cylinder boots
- Mast tilt (bottler's tilt 10° forward/5° backward)
- Tapered forks
- Fully tapered & polished forks
- Fork bar (wide carriage)
- High-load backrest
- Less forks
- Less backrest

Optional Equipment, continued

**LOAD HANDLING (HOSE & VALVE ASSEMBLY)**

- 3-way valve (no 3rd function hosing)
- 3-way valve (with 3rd function hosing)
- 4-way valve (no 3rd & 4th function hosing)
- 4-way valve (with 3rd function hosing)
- 4-way valve (with 3rd & 4th function hosing)
- Clamp release interlock
- Cascade hang-on sideshifter
- Integral sideshifter
- Hydraulic cushioned forks
- Hydraulic accumulator
- Hydraulic quick disconnects on 3rd lever
- Hydraulic quick disconnects on 4th lever

**LIGHTS & INDICATORS**

- Front combination lights (includes headlights)
- LED front combination headlights
- Rear combination lights
- LED rear combination light
- Rear working light
- LED rear working light
- Double rear working light
- LED double rear working light
- LED headlights
- Operator compartment light
- Strobe light, yellow (on top of OHG)
- Strobe light, yellow (on bottom of OHG)
- Rotary light, yellow (on top of OHG)
- Rotary light, yellow (on bottom of OHG)
- Deluxe display (includes tilt & load indicator)
- Back up buzzer
- Armrest horn

**BODY**

- Left-hand shift lever
- Joystick hydraulic controls with ErgoShift
- Speed and acceleration control (with load)
- Double accelerator pedal (one on each side of brake pedal)
- D2 pedal layout
- Rearview mirrors (left & right sides)
- Flat internal rearview mirror
- Panoramic rearview mirror
- Drive unit protector
- Battery slide-out with side covers
- Battery low lift-out with side covers
- Battery side extraction with fork pockets & side covers
- Touchpad keyless entry system
- Rear assist grip with horn button
- Impact sensor
- Auto height select
- 24-Volt power supply (80W)
- 12-Volt power supply (80W)
- Anti-static strap
- Cloth ORS 4-way adjustable full-suspension seat
- Swivel seat
- Orange seatbelt
- Raised overhead guard
- Steel cabin
- Comfort cabin with CD stereo
- Cabin without doors (includes windshield with wiper, roof & rear glass)
- Cabin without doors for raised OHG
- Canvas cabin (includes windshield with wiper & roof)
- Front windshield with wiper & roof
- Overhead guard sheet
- Heater
- Sun visor
- Clipboard

**WHEELS & TIRES**

- Solid pneumatic (Marangoni)
- Solid pneumatic (Continental)
- Non-marking solid pneumatic (Marangoni)
- Non-marking solid pneumatic (Continental)

**SPECIAL MODEL**

- Cold storage model
- Rustproof specification
- Fisherman spec model



TOYOTA

TOYOTA

## TRUCK SPECIFICATIONS

## MODEL NUMBERS

GENERAL DATA				05-8FBM20T	05-8FBMK25T	05-8FBM25T
Load Capacity		lb (kg)		4000 (2000)	5000 (2500)	5000 (2500)
Power Type		Voltage V		Battery 80	Battery 80	Battery 80
Operator Position				Seated Rider	Seated Rider	Seated Rider
Tire Type		Front / Rear		Solid Pneumatic	Solid Pneumatic	Solid Pneumatic
Wheels (x = driven)		Front / Rear		2x / 2	2x / 2	2x / 2
EXTERIOR DIMENSIONS				05-8FBM20T	05-8FBMK25T	05-8FBM25T
<b>A</b>	Maximum Fork Height (MFH, V mast, top of forks)	in (mm)		131.5 (3340)	131.5 (3340)	131.5 (3340)
<b>B</b>	Free-Lift (top of forks)	in (mm)		4.73 (120)	4.73 (120)	4.73 (120)
<b>C</b>	Fork Size (T x W x L)	in (mm)		1.6 x 5 x 42 (40 x 125 x 1070)	1.6 x 5 x 42 (40 x 125 x 1070)	1.6 x 5 x 42 (40 x 125 x 1070)
<b>D</b>	Tilt Range (forward / backward)	deg		4.5 / 8	4.5 / 8	4.5 / 8
<b>E</b>	Length to Fork Face	in (mm)		89.9 (2284)	89.9 (2284)	95.6 (2429)
<b>F</b>	Overall Width	in (mm)		47 (1195)	47 (1195)	47 (1195)
<b>G</b>	Mast Lowered Height	in (mm)		88 (2235)	88 (2235)	88 (2235)
<b>H</b>	Mast Extended Height (top of load backrest)	in (mm)		179.5 (4559)	179.5 (4559)	179.5 (4559)
<b>I</b>	Overhead Guard Height	in (mm)		87.2 (2215)	87.2 (2215)	87.2 (2215)
<b>J</b>	Turning Radius (outside)	in (mm)		78.9 (2003)	78.9 (2003)	84.2 (2138)
<b>K</b>	Load Distance <sup>1</sup>	in (mm)		16.5 (420)	16.5 (420)	16.5 (420)
	Basic Right-Angle Stacking Aisle Width <sup>2</sup>	in (mm)		95.4 (2423)	95.4 (2423)	100.7 (2558)
PERFORMANCE DATA				05-8FBM20T	05-8FBMK25T	05-8FBM25T
Speeds	Maximum Travel (forward / reverse)	Full Load	mph (km/h)	11.8 (19)	11.8 (19)	11.8 (19)
		No Load	mph (km/h)	12.4 (20)	12.4 (20)	12.4 (20)
	Lifting	Full Load	fpm (mm/sec)	96 (490)	91 (460)	91 (460)
		No Load	fpm (mm/sec)	124 (630)	124 (630)	124 (630)
	Lowering	Full Load	fpm (mm/sec)	106 (540)	100 (510)	100 (510)
		No Load	fpm (mm/sec)	86 (435)	94 (480)	94 (480)
Drawbar Pull	5-Minute Ratings		lbf (N)	4271 (19000)	4271 (19000)	4271 (19000)
	60-Minute Ratings		lbf (N)	2001 (8900)	2001 (8900)	2001 (8900)
Gradeability*	5-Minute Ratings		% (tan $\theta$ )	26 / 29	25 / 29	24 / 29
	30-Minute Ratings		% (tan $\theta$ )	17 / 29	16 / 28	15 / 25
TRUCK WEIGHTS				05-8FBM20T	05-8FBMK25T	05-8FBM25T
Total Weight Without Battery		lb (kg)		6420 (2912)	6603 (2995)	6495 (2946)
Weight Distribution (with standard battery)	Full Load	Front	lb (kg)	11576 (5251)	13210 (5992)	13320 (6042)
		Rear	lb (kg)	2277 (1033)	1828 (829)	2282 (1035)
	No Load	Front	lb (kg)	4568 (2072)	4960 (2250)	4941 (2241)
		Rear	lb (kg)	4687 (2126)	4894 (2220)	5097 (2312)
TIRES				05-8FBM20T	05-8FBMK25T	05-8FBM25T
Tires	Number (front / rear)			2 / 2	2 / 2	2 / 2
	Size	Front		23 x 9 - 10	23 x 9 - 10	23 x 9 - 10
		Rear		18 x 7 - 8	18 x 7 - 8	18 x 7 - 8
Wheelbase		in (mm)		62 (1575)	62 (1575)	67.7 (1720)
Tread	Front	in (mm)		38.8 (986)	38.8 (986)	38.8 (986)
	Rear	in (mm)		37 (940)	37 (940)	37 (940)
Underclearance (full load)	Minimum (mast)		in (mm)	3.7 (95)	3.7 (95)	3.7 (95)
	Center of Wheelbase		in (mm)	4.5 (115)	4.5 (115)	4.5 (115)
Brake	Service (foot)			Hydraulic	Hydraulic	Hydraulic
	Parking (auto)			Electro-Mechanical	Electro-Mechanical	Electro-Mechanical
POWER SYSTEM				05-8FBM20T	05-8FBMK25T	05-8FBM25T
Battery Compartment	Width	in		40.5	40.5	40.5
	Length	in		28	28	33.7
	Height	in		30.9	30.9	30.9
Battery (5-hour ratings)	Voltage/Capacity		V/Ah	80/420	80/560	80/700
	Min. Weight		lb	3435	3435	4107
Electric Motors	Drive	hp (kW)		26.8 (20)	26.8 (20)	26.8 (20)
	Load Handling	hp (kW)		34.2 (25.5)	34.2 (25.5)	34.2 (25.5)
Control Type		Drive, Load Handling, Power Steering		Transistor Inverter	Transistor Inverter	Transistor Inverter
Auxiliary Hydraulic Function Specifications (for attachments) <sup>3</sup>	Max. Operating Pressure		psi (bar)	2321 (160)	2321 (160)	2321 (160)
	Maximum Flow Rate		gpm (lmp)	10.6 (40)	10.6 (40)	10.6 (40)

\* Computed values.

<sup>1</sup> Centerline of front axle to front face of forks.<sup>2</sup> Add load length & clearance.<sup>3</sup> Values taken at Hydraulic Control Valve. Does not take into consideration losses through mast plumbing (hosing, fittings, QDs, etc.).

## TRUCK SPECIFICATIONS

## MODEL NUMBERS

GENERAL DATA				05-8FBMK30T	05-8FBM30T	05-8FBM35T
Load Capacity		lb (kg)		6000 (2722)	6000 (2722)	7000 (3175)
Power Type		Battery		Battery	Battery	Battery
		Voltage	V	80	80	80
Operator Position		Seated Rider		Seated Rider	Seated Rider	Seated Rider
Tire Type		Front / Rear		Solid Pneumatic	Solid Pneumatic	Solid Pneumatic
Wheels (x = driven)		Front / Rear		2x / 2	2x / 2	2x / 2
EXTERIOR DIMENSIONS				05-8FBMK30T	05-8FBM30T	05-8FBM35T
<b>A</b>	Maximum Fork Height (MFH, V mast, top of forks)	in (mm)		131.7 (3345)	131.7 (3345)	131.7 (3345)
<b>B</b>	Free-Lift (top of forks)	in (mm)		4.9 (125)	4.9 (125)	4.9 (125)
<b>C</b>	Fork Size (T x W x L)	in (mm)		1.8 x 5 x 42 (45 x 125 x 1070)	1.8 x 5 x 42 (45 x 125 x 1070)	1.8 x 5 x 42 (45 x 125 x 1070)
<b>D</b>	Tilt Range (forward / backward)	deg		4.5 / 8	4.5 / 8	4.5 / 8
<b>E</b>	Length to Fork Face	in (mm)		91.9 (2334)	96.4 (2449)	97.6 (2479)
<b>F</b>	Overall Width	in (mm)		47 (1195)	47 (1195)	47 (1195)
<b>G</b>	Mast Lowered Height	in (mm)		94.3 (2395)	94.3 (2395)	94.3 (2395)
<b>H</b>	Mast Extended Height (top of load backrest)	in (mm)		179.7 (4564)	179.7 (4564)	179.7 (4564)
<b>I</b>	Overhead Guard Height	in (mm)		87.2 (2215)	87.2 (2215)	87.2 (2215)
<b>J</b>	Turning Radius (outside)	in (mm)		80 (2032)	84.2 (2138)	85.3 (2167)
<b>K</b>	Load Distance <sup>1</sup>	in (mm)		17.3 (440)	18.5 (470)	17.3 (440)
	Basic Right-Angle Stacking Aisle Width <sup>2</sup>	in (mm)		97.3 (2471)	101.5 (2577)	102.6 (2606)
PERFORMANCE DATA				05-8FBMK30T	05-8FBM30T	05-8FBM35T
Speeds	Maximum Travel (forward / reverse)	Full Load	mph (km/h)	11.8 (19)	11.8 (19)	11.8 (19)
		No Load	mph (km/h)	12.4 (20)	12.4 (20)	12.4 (20)
	Lifting	Full Load	fpm (mm/sec)	75 (380)	75 (380)	69 (350)
		No Load	fpm (mm/sec)	108 (550)	108 (550)	108 (550)
	Lowering	Full Load	fpm (mm/sec)	110 (560)	110 (560)	110 (560)
		No Load	fpm (mm/sec)	83 (420)	83 (420)	87 (440)
Drawbar Pull	5-Minute Ratings		lbf (N)	4271 (19000)	4271 (19000)	4271 (19000)
	60-Minute Ratings		lbf (N)	2001 (8900)	2001 (8900)	2001 (8900)
Gradeability*	5-Minute Ratings		% (tan $\theta$ )	21 / 29	22 / 29	19 / 27
	30-Minute Ratings		% (tan $\theta$ )	13 / 23	13 / 23	11 / 21
TRUCK WEIGHTS				05-8FBMK30T	05-8FBM30T	05-8FBM35T
Total Weight Without Battery		lb (kg)		8027 (3641)	7271 (3298)	8223 (3730)
Weight Distribution (with standard battery)	Full Load	Front	lb (kg)	15390 (6981)	15483 (7023)	17084 (7749)
		Rear	lb (kg)	2072 (940)	1896 (860)	2249 (1020)
	No Load	Front	lb (kg)	5386 (2443)	5816 (2638)	5803 (2632)
		Rear	lb (kg)	6076 (2756)	5565 (2524)	6528 (2961)
TIRES				05-8FBMK30T	05-8FBM30T	05-8FBM35T
Tires	Number (front / rear)			2 / 2	2 / 2	2 / 2
	Size	Front		23 x 10 - 12	23 x 10 - 12	23 x 10 - 12
		Rear		18 x 7 - 8	18 x 7 - 8	18 x 7 - 8
Wheelbase		in (mm)		62 (1575)	67.7 (1720)	67.7 (1720)
Tread	Front	in (mm)		37.2 (946)	37.2 (946)	37.2 (946)
	Rear	in (mm)		37 (940)	37 (940)	37 (940)
Underclearance (full load)	Minimum (mast)		in (mm)	3.7 (95)	3.7 (95)	3.7 (95)
	Center of Wheelbase		in (mm)	4.5 (115)	4.5 (115)	4.5 (115)
Brake	Service (foot)			Hydraulic	Hydraulic	Hydraulic
	Parking (auto)			Electro-Mechanical	Electro-Mechanical	Electro-Mechanical
POWER SYSTEM				05-8FBMK30T	05-8FBM30T	05-8FBM35T
Battery Compartment	Width		in	40.5	40.5	40.5
	Length		in	28	33.7	33.7
	Height		in	30.9	30.9	30.9
Battery (5-hour ratings)	Voltage/Capacity		V/Ah	80/560	80/700	80/700
	Min. Weight		lb	3435	4107	4107
Electric Motors	Drive		hp (kW)	26.8 (20)	26.8 (20)	26.8 (20)
	Load Handling		hp (kW)	34.2 (25.5)	34.2 (25.5)	34.2 (25.5)
Control Type		Drive, Load Handling, Power Steering		Transistor Inverter	Transistor Inverter	Transistor Inverter
Auxiliary Hydraulic Function Specifications (for attachments) <sup>3</sup>	Max. Operating Pressure		psi (bar)	2321 (160)	2321 (160)	2321 (160)
	Maximum Flow Rate		gpm (lmp)	10.6 (40)	10.6 (40)	10.6 (40)

\* Computed values.

<sup>1</sup> Centerline of front axle to front face of forks.<sup>2</sup> Add load length & clearance.<sup>3</sup> Values taken at Hydraulic Control Valve. Does not take into consideration losses through mast plumbing (hosing, fittings, QDs, etc.).

**MODEL NUMBERS**

GENERAL DATA				8FBM40T	8FBM45T	8FBM50T
Load Capacity		lb (kg)		8000 (3640)	9000 (4090)	11000 (4990)
Power Type				Battery	Battery	Battery
		Voltage	V	80	80	80
Operator Position				Seated Rider	Seated Rider	Seated Rider
Tire Type		Front / Rear		Solid Pneumatic	Solid Pneumatic	Solid Pneumatic
Wheels (x = driven)		Front / Rear		2x / 2	2x / 2	2x / 2
EXTERIOR DIMENSIONS				8FBM40T	8FBM45T	8FBM50T
<b>A</b>	Maximum Fork Height (MFH, V mast, top of forks)	in (mm)		131.9 (3350)	131.9 (3350)	132.3 (3360)
<b>B</b>	Free-Lift (top of forks)	in (mm)		5.1 (130)	5.1 (130)	5.5 (140)
<b>C</b>	Fork Size (T x W x L)	in (mm)		1.8 x 5 x 42 (45 x 125 x 1070)	1.8 x 5 x 42 (45 x 125 x 1070)	1.8 x 5 x 42 (45 x 125 x 1070)
<b>D</b>	Tilt Range (forward / backward)	deg		5/10	5/10	5/10
<b>E</b>	Length to Fork Face	in (mm)		114.4 (2907)	116.0 (2947)	120.9 (3072)
<b>F</b>	Overall Width	in (mm)		53 (1345)	53.0 (1345)	56.7 (1440)
<b>G</b>	Mast Lowered Height	in (mm)		98.4 (2500)	98.4 (2500)	98.4 (2500)
<b>H</b>	Mast Extended Height (top of load backrest)	in (mm)		179.9 (4570)	179.9 (4570)	180.3 (4580)
<b>I</b>	Overhead Guard Height	in (mm)		92.9 (2360)	92.9 (2360)	92.9 (2360)
<b>J</b>	Turning Radius (outside)	in (mm)		100.1 (2543)	100.7 (2558)	105.7 (2686)
<b>K</b>	Load Distance <sup>1</sup>	in (mm)		20.4 (518)	20.4 (518)	20.8 (528)
	Basic Right-Angle Stacking Aisle Width <sup>2</sup>	in (mm)		120.5 (3061)	121.1 (3076)	126.5 (3214)
PERFORMANCE DATA				8FBM40T	8FBM45T	8FBM50T
Speeds	Maximum Travel (forward / reverse)	Full Load	mph (km/h)	11.0 (18)	11.0 (18)	11.0 (18)
		No Load	mph (km/h)	11.0 (18)	11.0 (18)	11.0 (18)
	Lifting	Full Load	fpm (mm/sec)	68.9 (350)	68.9 (350)	65.0 (330)
		No Load	fpm (mm/sec)	90.6 (460)	90.6 (460)	90.6 (460)
	Lowering	Full Load	fpm (mm/sec)	108.3 (550)	108.3 (550)	108.3 (550)
		No Load	fpm (mm/sec)	90.3 (460)	90.3 (460)	90.3 (460)
Drawbar Pull	5-Minute Ratings		lbf (N)	4946 (22,000)	4946 (22,000)	4946 (22,000)
	60-Minute Ratings		lbf (N)	2792 (12,420)	2792 (12,420)	2792 (12,420)
Gradeability*	5-Minute Ratings		% (tanθ)	15 / 25	14 / 24	13 / 23
	30-Minute Ratings		% (tanθ)	11.3 / 17.0	9.5 / 16.8	8.8 / 15.8
TRUCK WEIGHTS				8FBM40T	8FBM45T	8FBM50T
Total Weight Without Battery		lb (kg)		9652 (4378)	10,820 (4908)	12,220 (5543)
Weight Distribution (with standard battery)	Full Load	Front	lb (kg)	21,065 (9555)	22,622 (10,261)	24,948 (11,316)
		Rear	lb (kg)	2429 (1102)	2921 (1325)	3100 (1406)
	No Load	Front	lb (kg)	7844 (3558)	7749 (3515)	7822 (3548)
		Rear	lb (kg)	6832 (3099)	7875 (3572)	9200 (3548)
TIRES				8FBM40T	8FBM45T	8FBM50T
Tires	Number (front / rear)			2 / 2	2 / 2	2 / 2
	Size	Front		250 - 15	250 - 15	28 x 12.5 - 15
		Rear		23 x 9 - 10	23 x 9 - 10	23 x 9 - 10
Wheelbase		in (mm)		79.9 (2030)	79.9 (2030)	79.9 (2030)
Tread	Front	in (mm)		44.1 (1119)	44.1 (1119)	45.1 (1145)
	Rear	in (mm)		43.8 (1113)	43.8 (1113)	43.8 (1113)
Underclearance (full load)	Minimum (mast)		in (mm)	5.9 (150)	5.9 (150)	5.9 (150)
	Center of Wheelbase		in (mm)	5.7 (145)	5.7 (145)	5.7 (145)
Brake	Service (foot)			Hydraulic	Hydraulic	Hydraulic
	Parking (auto)			Electro-Mechanical	Electro-Mechanical	Electro-Mechanical
POWER SYSTEM				8FBM40T	8FBM45T	8FBM50T
Battery Compartment	Width	in		40.5	40.5	40.5
	Length	in		39.3	39.3	39.3
	Height	in		30.9	30.9	30.9
Battery (5-hour ratings)	Voltage/Capacity		V/Ah	80 / 840	80 / 840	80 / 840
	Min. Weight		lb	4802	4802	4802
Electric Motors	Drive	hp (kW)		33.8 (25.2)	33.8 (25.2)	33.8 (25.2)
	Load Handling	hp (kW)		34.2 (25.5)	34.2 (25.5)	34.2 (25.5)
Control Type	Drive, Load Handling, Power Steering			Transistor Inverter	Transistor Inverter	Transistor Inverter
Auxiliary Hydraulic Function Specifications (for attachments) <sup>3</sup>	Max. Operating Pressure		psi (bar)	2320-2610 (160-180) adjustable	2320-2610 (160-180) adjustable	2320-2610 (160-180) adjustable
	Maximum Flow Rate		gpm (lmp)	18.5 (70)	18.5 (70)	18.5 (70)

\* Computed values.

<sup>1</sup> Centerline of front axle to front face of forks.

<sup>2</sup> Add load length & clearance.

<sup>3</sup> Values taken at Hydraulic Control Valve. Does not take into consideration losses through mast plumbing (hosing, fittings, QDs, etc.).



TOYOTA

SAS

TOYOTA



EXTERIOR DIMENSIONS

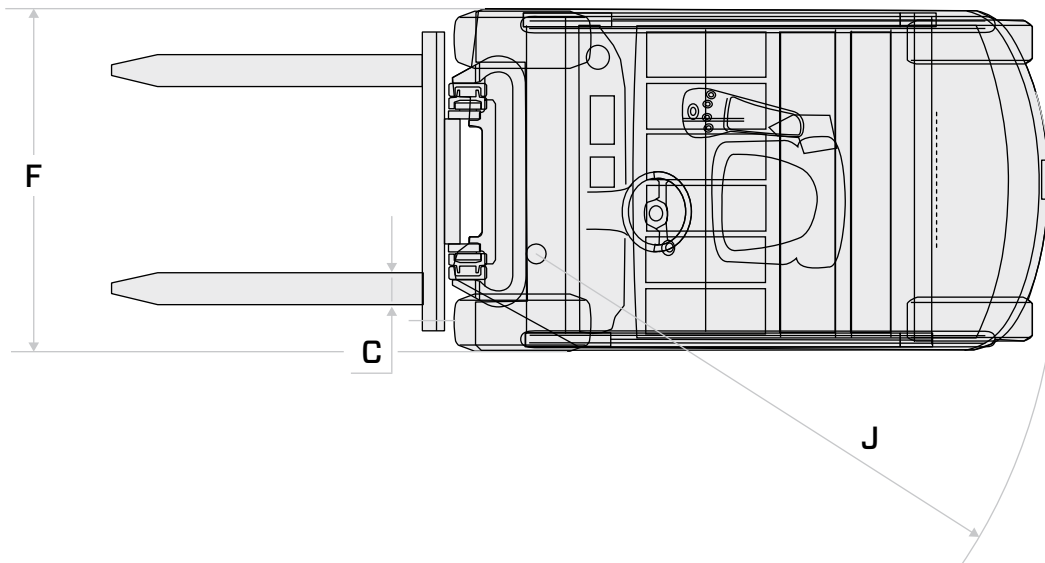
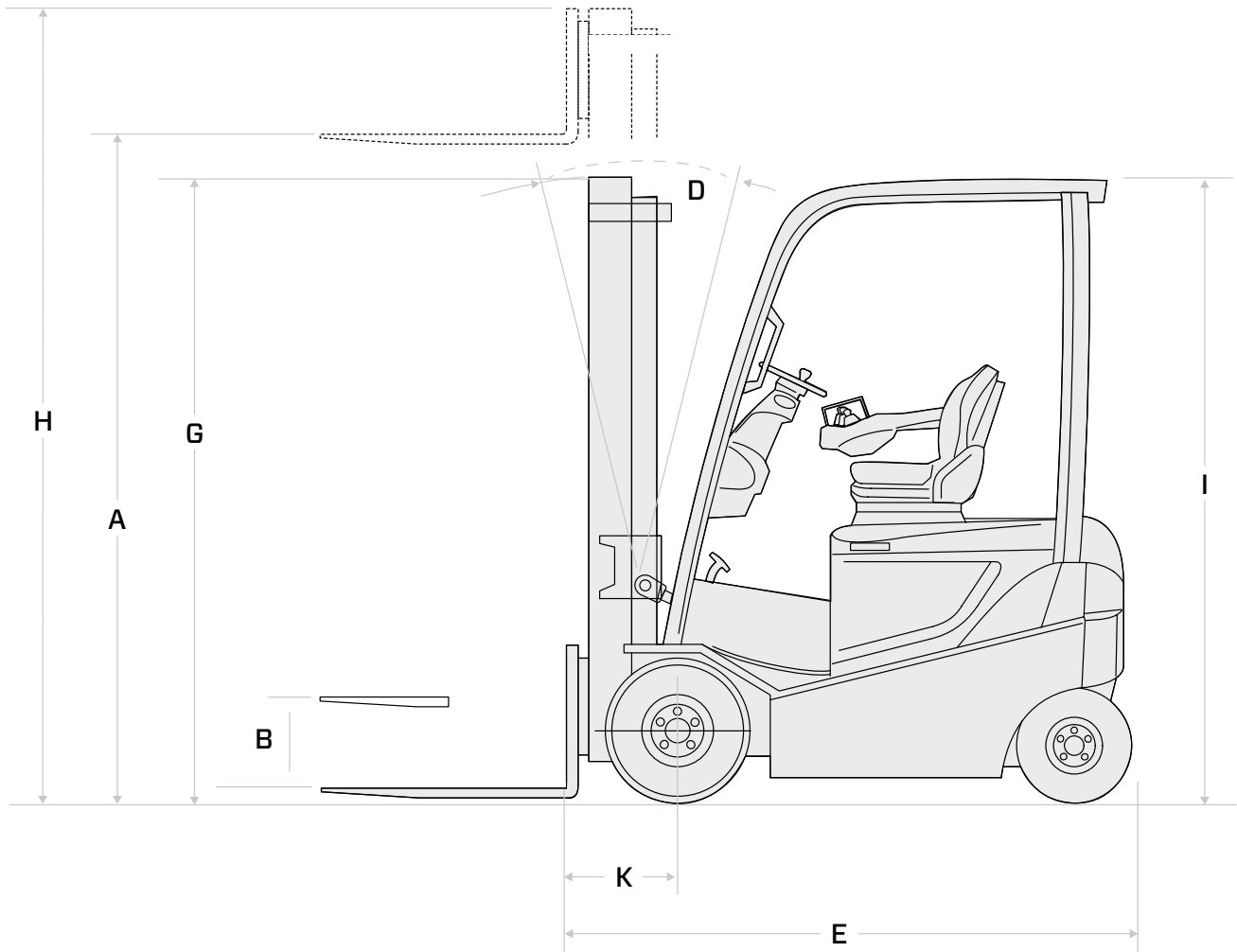

## MAST SPECIFICATIONS

MAST TYPE	MAXIMUM FORK HEIGHT (TOP OF FORKS)	OVERALL HEIGHT				FREE-LIFT		TILT RANGE		LOAD CAPACITY AT	
		LOWERED	EXTENDED		WITHOUT LOAD BACKREST	WITH STANDARD LOAD BACKREST <sup>1</sup>	FWD	BWD	24 IN. (610 MM) LOAD CENTER*	32 IN. (810 MM) LOAD CENTER*	
			WITHOUT LOAD BACKREST	WITH STANDARD LOAD BACKREST <sup>1</sup>							deg
05-8FBM20T											
Wide Visible (V)	119.5 (3040)	84 (2135)	145.6 (3699)	167.7 (4259)	4.73 (120)	4.73 (120)	4.5	8	4000 (1814)	3349 (1519)	
	131.5 (3340)	88 (2235)	157.4 (3999)	179.5 (4559)	4.73 (120)	4.73 (120)	4.5	8	4000 (1814)	3349 (1519)	
	147 (3740)	101.8 (2585)	173.2 (4399)	195.2 (4959)	4.73 (120)	4.73 (120)	4.5	8	4000 (1814)	3349 (1519)	
	159 (4040)	111.6 (2835)	185 (4699)	207.1 (5259)	4.73 (120)	4.73 (120)	4.5	8	4000 (1814)	3349 (1519)	
	179 (4540)	121.5 (3085)	204.7 (5199)	226.7 (5759)	4.73 (120)	4.73 (120)	4.5	8	4000 (1814)	3349 (1519)	
Full Free-Lift 2-Stage (FV)	119.5 (3040)	84 (2135)	145.6 (3699)	167.7 (4259)	59.5 (1511)	38 (965)	4.5	8	4000 (1814)	3349 (1519)	
	131.5 (3340)	88 (2235)	157.4 (3999)	179.5 (4559)	63.4 (1611)	41.9 (1065)	4.5	8	4000 (1814)	3349 (1519)	
	147 (3740)	101.8 (2585)	173.2 (4399)	195.2 (4959)	77.2 (1961)	55.7 (1415)	4.5	8	4000 (1814)	3349 (1519)	
	159 (4040)	111.6 (2835)	185 (4699)	207.1 (5259)	87.1 (2211)	65.6 (1665)	4.5	8	4000 (1814)	3349 (1519)	
Full Free-Lift 2-Stage, 4-Cylinder (FW)	119.5 (3040)	84 (2135)	145.6 (3699)	167.7 (4259)	60.6 (1540)	36 (915)	4.5	8	4000 (1814)	3349 (1519)	
	131.5 (3340)	88.8 (2255)	157.4 (3999)	179.5 (4559)	65.4 (1660)	40.7 (1035)	4.5	8	4000 (1814)	3349 (1519)	
	147 (3740)	98.6 (2505)	173.2 (4399)	195.2 (4959)	72.4 (1840)	50.6 (1285)	4.5	8	4000 (1814)	3349 (1519)	
	159 (4040)	104.5 (2655)	185 (4699)	207.1 (5259)	80.7 (2050)	56.5 (1435)	4.5	8	4000 (1814)	3349 (1519)	
Full Free-Lift 3-Stage (FSV)	171 (4340)	84 (2135)	196.8 (4999)	218.9 (5559)	58.1 (1476)	37.6 (955)	4.5	8	4000 (1814)	3349 (1519)	
	186.5 (4740)	88 (2235)	212.6 (5399)	234.6 (5959)	62 (1576)	41.5 (1055)	4.5	8	4000 (1814)	3349 (1519)	
	198 (5040)	94.3 (2395)	224.4 (5699)	246.4 (6259)	68.3 (1736)	47.8 (1215)	4.5	8	4000 (1814)	3349 (1519)	
	218 (5540)	101.8 (2585)	244.1 (6199)	266.1 (6759)	75.8 (1926)	55.3 (1405)	4.5	8	4000 (1814)	3349 (1519)	
	238 (6040)	111.6 (2835)	263.7 (6699)	285.8 (7259)	85.7 (2176)	65.2 (1655)	4.5	8	3307 (1500)	2769 (1256)	
	257 (6540)	121.5 (3085)	283.4 (7199)	305.5 (7759)	95.5 (2426)	75 (1905)	4.5	8	2800 (1270)	2345 (1063)	
Full Free-Lift 3-Stage, 4-Cylinder (FSW)	173 (4400)	82.1 (2085)	199.2 (5059)	221.2 (5619)	58.3 (1480)	34.1 (865)	4.5	8	4000 (1814)	3349 (1519)	
	186.5 (4740)	86.8 (2205)	212.6 (5399)	234.6 (5959)	63 (1600)	38.8 (985)	4.5	8	4000 (1814)	3349 (1519)	
	198 (5040)	90.7 (2305)	224.4 (5699)	246.4 (6259)	67 (1700)	42.7 (1085)	4.5	8	4000 (1814)	3349 (1519)	
	218 (5540)	98.6 (2505)	244.1 (6199)	266.1 (6759)	74.8 (1900)	50.6 (1285)	4.5	8	4000 (1814)	3349 (1519)	
	238 (6040)	104.5 (2655)	263.7 (6699)	285.8 (7259)	80.7 (2050)	56.5 (1435)	4.5	8	3307 (1500)	2769 (1256)	
	257 (6540)	112.4 (2855)	283.4 (7199)	305.5 (7759)	88.6 (2250)	64.4 (1635)	4.5	8	2800 (1270)	2345 (1063)	

MAST TYPE	MAXIMUM FORK HEIGHT (TOP OF FORKS)	OVERALL HEIGHT				FREE-LIFT		TILT RANGE		LOAD CAPACITY AT	
		LOWERED	EXTENDED		WITHOUT LOAD BACKREST	WITH STANDARD LOAD BACKREST <sup>1</sup>	FWD	BWD	24 IN. (610 MM) LOAD CENTER*	32 IN. (810 MM) LOAD CENTER*	
			WITHOUT LOAD BACKREST	WITH STANDARD LOAD BACKREST <sup>1</sup>							deg
05-8FBMK25T											
Wide Visible (V)	119.5 (3040)	84 (2135)	145.6 (3699)	167.7 (4259)	4.73 (120)	4.73 (120)	4.5	8	5000 (2268)	3968 (1800)	
	131.5 (3340)	88 (2235)	157.4 (3999)	179.5 (4559)	4.73 (120)	4.73 (120)	4.5	8	5000 (2268)	3968 (1800)	
	147 (3740)	101.8 (2585)	173.2 (4399)	195.2 (4959)	4.73 (120)	4.73 (120)	4.5	8	5000 (2268)	3968 (1800)	
	159 (4040)	111.6 (2835)	185 (4699)	207.1 (5259)	4.73 (120)	4.73 (120)	4.5	8	5000 (2268)	3968 (1800)	
	179 (4540)	121.5 (3085)	204.7 (5199)	226.7 (5759)	4.73 (120)	4.73 (120)	4.5	8	5000 (2268)	3968 (1800)	
Full Free-Lift 2-Stage (FV)	119.5 (3040)	84 (2135)	145.6 (3699)	167.7 (4259)	59.5 (1511)	38 (965)	4.5	8	5000 (2268)	3968 (1800)	
	131.5 (3340)	88 (2235)	157.4 (3999)	179.5 (4559)	63.4 (1611)	41.9 (1065)	4.5	8	5000 (2268)	3968 (1800)	
	147 (3740)	101.8 (2585)	173.2 (4399)	195.2 (4959)	77.2 (1961)	55.7 (1415)	4.5	8	5000 (2268)	3968 (1800)	
	159 (4040)	111.6 (2835)	185 (4699)	207.1 (5259)	87.1 (2211)	65.6 (1665)	4.5	8	5000 (2268)	3968 (1800)	
Full Free-Lift 2-Stage, 4-Cylinder (FW)	119.5 (3040)	84 (2135)	145.6 (3699)	167.7 (4259)	60.6 (1540)	36 (915)	4.5	8	5000 (2268)	3968 (1800)	
	131.5 (3340)	88.8 (2255)	157.4 (3999)	179.5 (4559)	65.4 (1660)	40.7 (1035)	4.5	8	5000 (2268)	3968 (1800)	
	147 (3740)	98.6 (2505)	173.2 (4399)	195.2 (4959)	72.4 (1840)	50.6 (1285)	4.5	8	5000 (2268)	3968 (1800)	
	159 (4040)	104.5 (2655)	185 (4699)	207.1 (5259)	80.7 (2050)	56.5 (1435)	4.5	8	5000 (2268)	3968 (1800)	
Full Free-Lift 3-Stage (FSV)	171 (4340)	84 (2135)	196.8 (4999)	218.9 (5559)	58.1 (1476)	37.6 (955)	4.5	8	4938 (2240)	3968 (1800)	
	186.5 (4740)	88 (2235)	212.6 (5399)	234.6 (5959)	62 (1576)	41.5 (1055)	4.5	8	4828 (2190)	3968 (1800)	
	198 (5040)	94.3 (2395)	224.4 (5699)	246.4 (6259)	68.3 (1736)	47.8 (1215)	4.5	8	4740 (2150)	3968 (1800)	
	218 (5540)	101.8 (2585)	244.1 (6199)	266.1 (6759)	75.8 (1926)	55.3 (1405)	4.5	8	4145 (1880)	3483 (1580)	
	238 (6040)	111.6 (2835)	263.7 (6699)	285.8 (7259)	85.7 (2176)	65.2 (1655)	4.5	8	3307 (1500)	2778 (1260)	
	257 (6540)	121.5 (3085)	283.4 (7199)	305.5 (7759)	95.5 (2426)	75 (1905)	4.5	8	2800 (1270)	2337 (1270)	
Full Free-Lift 3-Stage, 4-Cylinder (FSW)	173 (4400)	82.1 (2085)	199.2 (5059)	221.2 (5619)	58.3 (1480)	34.1 (865)	4.5	8	4938 (2240)	3968 (1800)	
	186.5 (4740)	86.8 (2205)	212.6 (5399)	234.6 (5959)	63 (1600)	38.8 (985)	4.5	8	4828 (2190)	3968 (1800)	
	198 (5040)	90.7 (2305)	224.4 (5699)	246.4 (6259)	67 (1700)	42.7 (1085)	4.5	8	4740 (2150)	3968 (1800)	
	218 (5540)	98.6 (2505)	244.1 (6199)	266.1 (6759)	74.8 (1900)	50.6 (1285)	4.5	8	4145 (1880)	3483 (1580)	
	238 (6040)	104.5 (2655)	263.7 (6699)	285.8 (7259)	80.7 (2050)	56.5 (1435)	4.5	8	3307 (1500)	2778 (1260)	
	257 (6540)	112.4 (2855)	283.4 (7199)	305.5 (7759)	88.6 (2250)	64.4 (1635)	4.5	8	2800 (1270)	2337 (1270)	

<sup>1</sup> Height of standard load backrest is 48" (1220 mm).  
 \* All capacities of 1500 lbs. or less are subject to a secondary review by Toyota.

MAST TYPE	MAXIMUM FORK HEIGHT (TOP OF FORKS)	OVERALL HEIGHT				FREE-LIFT		TILT RANGE		LOAD CAPACITY AT	
		LOWERED	EXTENDED		WITHOUT LOAD BACKREST	WITH STANDARD LOAD BACKREST <sup>1</sup>	FWD	BWD	24 IN. (610 MM) LOAD CENTER*	32 IN. (810 MM) LOAD CENTER*	
			WITHOUT LOAD BACKREST	WITH STANDARD LOAD BACKREST <sup>1</sup>							
in (mm)	in (mm)	in (mm)	in (mm)	in (mm)	in (mm)	deg	deg	lb (kg)	lb (kg)		
<b>05-8FBM25T</b>											
Wide Visible (V)	119.5 (3040)	84 (2135)	145.6 (3699)	167.7 (4259)	4.73 (120)	4.73 (120)	4.5	8	5000 (2268)	3968 (1800)	
	131.5 (3340)	88 (2235)	157.4 (3999)	179.5 (4559)	4.73 (120)	4.73 (120)	4.5	8	5000 (2268)	3968 (1800)	
	147 (3740)	101.8 (2585)	173.2 (4399)	195.2 (4959)	4.73 (120)	4.73 (120)	4.5	8	5000 (2268)	3968 (1800)	
	159 (4040)	111.6 (2835)	185 (4699)	207.1 (5259)	4.73 (120)	4.73 (120)	4.5	8	5000 (2268)	3968 (1800)	
Full Free-Lift 2-Stage (FV)	119.5 (3040)	84 (2135)	145.6 (3699)	167.7 (4259)	59.5 (1511)	38 (965)	4.5	8	5000 (2268)	3968 (1800)	
	131.5 (3340)	88 (2235)	157.4 (3999)	179.5 (4559)	63.4 (1611)	41.9 (1065)	4.5	8	5000 (2268)	3968 (1800)	
	147 (3740)	101.8 (2585)	173.2 (4399)	195.2 (4959)	77.2 (1961)	55.7 (1415)	4.5	8	5000 (2268)	3968 (1800)	
Full Free-Lift 2-Stage, 4-Cylinder (FW)	119.5 (3040)	84 (2135)	145.6 (3699)	167.7 (4259)	60.6 (1540)	36 (915)	4.5	8	5000 (2268)	3968 (1800)	
	131.5 (3340)	88.8 (2255)	157.4 (3999)	179.5 (4559)	65.4 (1660)	40.7 (1035)	4.5	8	5000 (2268)	3968 (1800)	
	147 (3740)	98.6 (2505)	173.2 (4399)	195.2 (4959)	72.4 (1840)	50.6 (1285)	4.5	8	5000 (2268)	3968 (1800)	
Full Free-Lift 3-Stage (FSV)	159 (4040)	104.5 (2655)	185 (4699)	207.1 (5259)	80.7 (2050)	56.5 (1435)	4.5	8	5000 (2268)	3968 (1800)	
	171 (4340)	84 (2135)	196.8 (4999)	218.9 (5559)	58.1 (1476)	37.6 (955)	4.5	8	5000 (2268)	3968 (1800)	
	186.5 (4740)	88 (2235)	212.6 (5399)	234.6 (5959)	62 (1576)	41.5 (1055)	4.5	8	5000 (2268)	3968 (1800)	
	198 (5040)	94.3 (2395)	224.4 (5699)	246.4 (6259)	68.3 (1736)	47.8 (1215)	4.5	8	5000 (2268)	3968 (1800)	
	218 (5540)	101.8 (2585)	244.1 (6199)	266.1 (6759)	75.8 (1926)	55.3 (1405)	4.5	8	5000 (2268)	3968 (1800)	
Full Free-Lift 3-Stage, 4-Cylinder (FSW)	238 (6040)	111.6 (2835)	263.7 (6699)	285.8 (7259)	85.7 (2176)	65.2 (1655)	4.5	8	3990 (1810)	3351 (1520)	
	257 (6540)	121.5 (3085)	283.4 (7199)	305.5 (7759)	95.5 (2426)	75 (1905)	4.5	8	3880 (1760)	3263 (1480)	
	173 (4400)	82.1 (2085)	199.2 (5059)	221.2 (5619)	58.3 (1480)	34.1 (865)	4.5	8	5000 (2268)	3968 (1800)	
	186.5 (4740)	86.8 (2205)	212.6 (5399)	234.6 (5959)	63 (1600)	38.8 (985)	4.5	8	5000 (2268)	3968 (1800)	
	198 (5040)	90.7 (2305)	224.4 (5699)	246.4 (6259)	67 (1700)	42.7 (1085)	4.5	8	5000 (2268)	3968 (1800)	

MAST TYPE	MAXIMUM FORK HEIGHT (TOP OF FORKS)	OVERALL HEIGHT				FREE-LIFT		TILT RANGE		LOAD CAPACITY AT	
		LOWERED	EXTENDED		WITHOUT LOAD BACKREST	WITH STANDARD LOAD BACKREST <sup>1</sup>	FWD	BWD	24 IN. (610 MM) LOAD CENTER*	32 IN. (810 MM) LOAD CENTER*	
			WITHOUT LOAD BACKREST	WITH STANDARD LOAD BACKREST <sup>1</sup>							
in (mm)	in (mm)	in (mm)	in (mm)	in (mm)	in (mm)	deg	deg	lb (kg)	lb (kg)		
<b>05-8FBMK30T</b>											
Wide Visible (V)	118 (3005)	87.2 (2215)	145.9 (3705)	166.3 (4224)	4.9 (125)	4.9 (125)	4.5	8	6000 (2722)	5000 (2268)	
	132 (3345)	94.3 (2395)	159.3 (4045)	179.7 (4564)	4.9 (125)	4.9 (125)	4.5	8	6000 (2722)	5000 (2268)	
	147.5 (3745)	101.8 (2585)	175 (4445)	195.2 (4959)	4.9 (125)	4.9 (125)	4.5	8	6000 (2722)	5000 (2268)	
	159 (4045)	111.6 (2835)	186.8 (4745)	207.3 (5264)	4.9 (125)	4.9 (125)	4.5	8	6000 (2722)	5000 (2268)	
Full Free-Lift 2-Stage (FV)	179 (4545)	121.5 (3085)	206.5 (5245)	226.9 (5764)	4.9 (125)	4.9 (125)	4.5	8	6000 (2722)	5000 (2268)	
	120 (3045)	83.7 (2125)	145.9 (3705)	166.3 (4224)	54.9 (1395)	36 (915)	4.5	8	6000 (2722)	5000 (2268)	
	132 (3345)	88.8 (2255)	159.3 (4045)	179.7 (4564)	59.6 (1515)	40.7 (1035)	4.5	8	6000 (2722)	5000 (2268)	
Full Free-Lift 2-Stage, 4-Cylinder (FW)	147.5 (3745)	101.8 (2585)	175 (4445)	195.2 (4959)	72.6 (1845)	53.7 (1365)	4.5	8	6000 (2722)	5000 (2268)	
	159 (4045)	111.6 (2835)	186.8 (4745)	207.3 (5264)	72.6 (1845)	53.7 (1365)	4.5	8	6000 (2722)	5000 (2268)	
	118 (3005)	86 (2185)	145.9 (3705)	166.3 (4224)	59.4 (1510)	38 (965)	4.5	8	6000 (2722)	5000 (2268)	
Full Free-Lift 3-Stage (FSV)	132 (3345)	92.7 (2355)	159.3 (4045)	179.7 (4564)	66.9 (1700)	44.7 (1135)	4.5	8	6000 (2722)	5000 (2268)	
	147.5 (3745)	100.6 (2555)	175 (4445)	195.2 (4959)	74.8 (1900)	52.6 (1335)	4.5	8	6000 (2722)	5000 (2268)	
	159 (4045)	108.5 (2755)	186.8 (4745)	207.3 (5264)	80.3 (2040)	60.4 (1535)	4.5	8	6000 (2722)	5000 (2268)	
Full Free-Lift 3-Stage, 4-Cylinder (FSW)	171 (4345)	84 (2135)	198.6 (5045)	219.1 (5564)	60.2 (1530)	40.9 (1040)	4.5	8	5700 (2585)	4410 (2000)	
	187 (4745)	88 (2235)	214.4 (5445)	234.8 (5964)	67.3 (1710)	48 (1220)	4.5	8	5700 (2585)	4410 (2000)	
	198.5 (5045)	94.3 (2395)	246.6 (5745)	266.3 (6264)	74.8 (1900)	55.5 (1410)	4.5	8	5700 (2585)	4410 (2000)	
	218 (5545)	101.8 (2585)	245.9 (6245)	266.3 (6764)	84.6 (2150)	65.4 (1660)	4.5	8	5335 (2420)	4410 (2000)	
	238 (6045)	111.6 (2835)	265.6 (6745)	286 (7264)	94.5 (2400)	75.2 (1910)	4.5	8	4321 (1960)	3638 (1650)	
Full Free-Lift 3-Stage, 4-Cylinder (FSW)	258 (6545)	121.5 (3085)	285.2 (7245)	305.7 (7764)	104.3 (2650)	85 (2160)	4.5	8	3594 (1630)	3020 (1370)	
	173 (4395)	86 (2185)	200.6 (5095)	221 (5614)	60.2 (1530)	38 (965)	4.5	8	5700 (2585)	4410 (2000)	
	187 (4745)	90.7 (2305)	214.4 (5445)	234.8 (5964)	65 (1650)	42.7 (1085)	4.5	8	5700 (2585)	4410 (2000)	
	198.5 (5045)	94.7 (2405)	246.6 (5745)	266.3 (6264)	68.9 (1750)	46.7 (1185)	4.5	8	5700 (2585)	4410 (2000)	
	218 (5545)	102.6 (2605)	245.9 (6245)	266.3 (6764)	76.8 (1950)	54.5 (1385)	4.5	8	5335 (2420)	4410 (2000)	

<sup>1</sup> Height of standard load backrest is 48" (1220 mm).  
\* All capacities of 1500 lbs. or less are subject to a secondary review by Toyota.

# MAST SPECIFICATIONS

MAST TYPE	MAXIMUM FORK HEIGHT (TOP OF FORKS)	OVERALL HEIGHT				FREE-LIFT		TILT RANGE		LOAD CAPACITY AT	
		LOWERED	EXTENDED		WITHOUT LOAD BACKREST	WITH STANDARD LOAD BACKREST <sup>1</sup>	FWD	BWD	24 IN. (610 MM) LOAD CENTER*	32 IN. (810 MM) LOAD CENTER*	
			WITHOUT LOAD BACKREST	WITH STANDARD LOAD BACKREST <sup>1</sup>							deg
05-8FBM30T											
Wide Visible (V)	118 (3005)	87.2 (2215)	145.9 (3705)	166.3 (4224)	4.9 (125)	4.9 (125)	4.5	8	6000 (2722)	5000 (2268)	
	132 (3345)	94.3 (2395)	159.3 (4045)	179.7 (4564)	4.9 (125)	4.9 (125)	4.5	8	6000 (2722)	5000 (2268)	
	147.5 (3745)	101.8 (2585)	175 (4445)	131.3 (3334)	4.9 (125)	4.9 (125)	4.5	8	6000 (2722)	5000 (2268)	
	159 (4045)	111.6 (2835)	186.8 (4745)	207.3 (5264)	4.9 (125)	4.9 (125)	4.5	8	6000 (2722)	5000 (2268)	
Full Free-Lift 2-Stage (FV)	120 (3045)	83.7 (2125)	145.9 (3705)	166.3 (4224)	54.9 (1395)	36 (915)	4.5	8	6000 (2722)	5000 (2268)	
	132 (3345)	88.8 (2255)	159.3 (4045)	179.7 (4564)	59.6 (1515)	40.7 (1035)	4.5	8	6000 (2722)	5000 (2268)	
	147.5 (3745)	101.8 (2585)	175 (4445)	131.3 (3334)	72.6 (1845)	53.7 (1365)	4.5	8	6000 (2722)	5000 (2268)	
	159 (4045)	111.6 (2835)	186.8 (4745)	207.3 (5264)	72.6 (1845)	53.7 (1365)	4.5	8	6000 (2722)	5000 (2268)	
Full Free-Lift 2-Stage, 4-Cylinder (FW)	118 (3005)	86 (2185)	145.9 (3705)	166.3 (4224)	59.4 (1510)	38 (965)	4.5	8	6000 (2722)	5000 (2268)	
	132 (3345)	92.7 (2355)	159.3 (4045)	179.7 (4564)	66.9 (1700)	44.7 (1135)	4.5	8	6000 (2722)	5000 (2268)	
	147.5 (3745)	100.6 (2555)	175 (4445)	131.3 (3334)	74.8 (1900)	52.6 (1335)	4.5	8	6000 (2722)	5000 (2268)	
	159 (4045)	108.5 (2755)	186.8 (4745)	207.3 (5264)	80.3 (2040)	60.4 (1535)	4.5	8	6000 (2722)	5000 (2268)	
Full Free-Lift 3-Stage (FSV)	171 (4345)	84 (2135)	198.6 (5045)	219.1 (5564)	60.2 (1530)	40.9 (1040)	4.5	8	5700 (2585)	4410 (2000)	
	187 (4745)	88 (2235)	214.4 (5445)	234.8 (5964)	67.3 (1710)	48 (1220)	4.5	8	5700 (2585)	4410 (2000)	
	198.5 (5045)	94.3 (2395)	246.6 (5745)	246.6 (6264)	74.8 (1900)	55.5 (1410)	4.5	8	5700 (2585)	4410 (2000)	
	218 (5545)	101.8 (2585)	245.9 (6245)	266.3 (6764)	84.6 (2150)	65.4 (1660)	4.5	8	5335 (2420)	4410 (2000)	
	238 (6045)	111.6 (2835)	265.6 (6745)	286 (7264)	94.5 (2400)	75.2 (1910)	4.5	8	4387 (1990)	3682 (1670)	
	258 (6545)	121.5 (3085)	285.2 (7245)	305.7 (7764)	104.3 (2650)	85 (2160)	4.5	8	4167 (1890)	3505 (1590)	
Full Free-Lift 3-Stage, 4-Cylinder (FSW)	173 (4395)	86 (2185)	200.6 (5095)	221 (5614)	60.2 (1530)	38 (965)	4.5	8	5700 (2585)	4410 (2000)	
	187 (4745)	90.7 (2305)	214.4 (5445)	234.8 (5964)	65 (1650)	42.7 (1085)	4.5	8	5700 (2585)	4410 (2000)	
	198.5 (5045)	94.7 (2405)	246.6 (5745)	246.6 (6264)	68.9 (1750)	46.7 (1185)	4.5	8	5700 (2585)	4410 (2000)	
	218 (5545)	102.6 (2605)	245.9 (6245)	266.3 (6764)	76.8 (1950)	54.5 (1385)	4.5	8	5335 (2420)	4410 (2000)	
	238 (6045)	108.5 (2755)	265.6 (6745)	286 (7264)	82.7 (2100)	60.4 (1535)	4.5	8	4387 (1990)	3682 (1670)	
	258 (6545)	116.3 (2955)	285.2 (7245)	305.7 (7764)	90.6 (2300)	68.3 (1735)	4.5	8	4167 (1890)	3505 (1590)	

MAST TYPE	MAXIMUM FORK HEIGHT (TOP OF FORKS)	OVERALL HEIGHT				FREE-LIFT		TILT RANGE		LOAD CAPACITY AT	
		LOWERED	EXTENDED		WITHOUT LOAD BACKREST	WITH STANDARD LOAD BACKREST <sup>1</sup>	FWD	BWD	24 IN. (610 MM) LOAD CENTER*	32 IN. (810 MM) LOAD CENTER*	
			WITHOUT LOAD BACKREST	WITH STANDARD LOAD BACKREST <sup>1</sup>							deg
05-8FBM35T											
Wide Visible (V)	118 (3005)	87.2 (2215)	145.9 (3705)	166.3 (4224)	4.9 (125)	4.9 (125)	4.5	8	7000 (3175)	5180 (2350)	
	132 (3345)	94.3 (2395)	159.3 (4045)	179.7 (4564)	4.9 (125)	4.9 (125)	4.5	8	7000 (3175)	5180 (2350)	
	147.5 (3745)	101.8 (2585)	175 (4445)	131.3 (3334)	4.9 (125)	4.9 (125)	4.5	8	7000 (3175)	5180 (2350)	
	159 (4045)	111.6 (2835)	186.8 (4745)	207.3 (5264)	4.9 (125)	4.9 (125)	4.5	8	7000 (3175)	5180 (2350)	
Full Free-Lift 2-Stage (FV)	120 (3045)	83.7 (2125)	145.9 (3705)	166.3 (4224)	54.9 (1395)	36 (915)	4.5	8	7000 (3175)	5180 (2350)	
	132 (3345)	88.8 (2255)	159.3 (4045)	179.7 (4564)	59.6 (1515)	40.7 (1035)	4.5	8	7000 (3175)	5180 (2350)	
	147.5 (3745)	101.8 (2585)	175 (4445)	131.3 (3334)	72.6 (1845)	53.7 (1365)	4.5	8	7000 (3175)	5180 (2350)	
	159 (4045)	111.6 (2835)	186.8 (4745)	207.3 (5264)	72.6 (1845)	53.7 (1365)	4.5	8	7000 (3175)	5180 (2350)	
Full Free-Lift 2-Stage, 4-Cylinder (FW)	118 (3005)	86 (2185)	145.9 (3705)	166.3 (4224)	59.4 (1510)	38 (965)	4.5	8	7000 (3175)	5180 (2350)	
	132 (3345)	92.7 (2355)	159.3 (4045)	179.7 (4564)	66.9 (1700)	44.7 (1135)	4.5	8	7000 (3175)	5180 (2350)	
	147.5 (3745)	100.6 (2555)	175 (4445)	131.3 (3334)	74.8 (1900)	52.6 (1335)	4.5	8	7000 (3175)	5180 (2350)	
	159 (4045)	108.5 (2755)	186.8 (4745)	207.3 (5264)	80.3 (2040)	60.4 (1535)	4.5	8	7000 (3175)	5180 (2350)	
Full Free-Lift 3-Stage (FSV)	171 (4345)	87.2 (2215)	198.6 (5045)	219.1 (5564)	60.2 (1530)	40.9 (1040)	4.5	8	6834 (3100)	5400 (2449)	
	187 (4745)	94.3 (2395)	214.4 (5445)	234.8 (5964)	67.3 (1710)	48 (1220)	4.5	8	6834 (3100)	5400 (2449)	
	198.5 (5045)	101.8 (2585)	246.6 (5745)	246.6 (6264)	74.8 (1900)	55.5 (1410)	4.5	8	6768 (3070)	5400 (2449)	
	218 (5545)	111.6 (2835)	245.9 (6245)	266.3 (6764)	84.6 (2150)	65.4 (1660)	4.5	8	6504 (2950)	5400 (2449)	
	238 (6045)	121.5 (3085)	265.6 (6745)	286 (7264)	94.5 (2400)	75.2 (1910)	4.5	8	5578 (2530)	4696 (2130)	
	258 (6545)	131.3 (3335)	285.2 (7245)	305.7 (7764)	104.3 (2650)	85 (2160)	4.5	8	4497 (2040)	3792 (1720)	
Full Free-Lift 3-Stage, 4-Cylinder (FSW)	173 (4395)	86 (2185)	200.6 (5095)	221 (5614)	60.2 (1530)	38 (965)	4.5	8	6834 (3100)	5400 (2449)	
	187 (4745)	90.7 (2305)	214.4 (5445)	234.8 (5964)	65 (1650)	42.7 (1085)	4.5	8	6834 (3100)	5400 (2449)	
	198.5 (5045)	94.7 (2405)	246.6 (5745)	246.6 (6264)	68.9 (1750)	46.7 (1185)	4.5	8	6768 (3070)	5400 (2449)	
	218 (5545)	102.6 (2605)	245.9 (6245)	266.3 (6764)	76.8 (1950)	54.5 (1385)	4.5	8	6504 (2950)	5400 (2449)	
	238 (6045)	108.5 (2755)	265.6 (6745)	286 (7264)	82.7 (2100)	60.4 (1535)	4.5	8	5578 (2530)	4696 (2130)	
	258 (6545)	116.3 (2955)	285.2 (7245)	305.7 (7764)	90.6 (2300)	68.3 (1735)	4.5	8	4497 (2040)	3792 (1720)	

<sup>1</sup> Height of standard load backrest is 48" (1220 mm).  
 \* All capacities of 1500 lbs. or less are subject to a secondary review by Toyota.

MAST TYPE	MAXIMUM FORK HEIGHT (TOP OF FORKS)	OVERALL HEIGHT			FREE-LIFT		TILT RANGE		LOAD CAPACITY AT
		LOWERED	EXTENDED		WITHOUT LOAD BACKREST	WITH STANDARD LOAD BACKREST <sup>1</sup>	FWD	BWD	24 IN. (610 MM) LOAD CENTER*
			WITHOUT LOAD BACKREST	WITH STANDARD LOAD BACKREST <sup>1</sup>					lb (kg)
	in (mm)	in (mm)	in (mm)	in (mm)	in (mm)	in (mm)	deg	deg	lb (kg)
<b>8FBM40T</b>									
Wide Visible (V)	120 (3050)	92.9 (2360)	151.8 (3856)	165.4 (4200)	3.15 (80)	3.15 (80)	5	10	8000 (3640)
	132 (3350)	98.4 (2500)	163.6 (4156)	177.2 (4500)	3.15 (80)	3.15 (80)	5	10	8000 (3640)
	147.5 (3750)	108.3 (2750)	179.5 (4560)	192.9 (4900)	3.15 (80)	3.15 (80)	5	10	8000 (3640)
	159 (4050)	113.4 (2880)	191.2 (4856)	204.7 (5200)	3.15 (80)	3.15 (80)	5	10	8000 (3640)
	179 (4550)	123.2 (3130)	210.9 (5356)	224.4 (5700)	3.15 (80)	3.15 (80)	5	6	8000 (3640)
	199 (5050)	133.1 (3380)	230.6 (5856)	244.1 (6200)	3.15 (80)	3.15 (80)	5	6	8000 (3640)
Full Free-Lift 2-Stage (FV)	218.5 (5550)	142.9 (3630)	250.2 (6356)	263.8 (6700)	3.15 (80)	3.15 (80)	5	6	7914 (3590)
	120 (3050)	92.9 (2360)	153.1 (3890)	165.4 (4200)	57.9 (1470)	45.7 (1160)	5	10	8000 (3640)
	132 (3350)	98.4 (2500)	165 (4190)	177.2 (4500)	63.4 (1610)	48.8 (1240)	5	10	8000 (3640)
	147.5 (3750)	108.3 (2750)	180.7 (4590)	192.9 (4900)	73.2 (1860)	51.2 (1300)	5	10	8000 (3640)
Full Free-Lift 2-Stage, 4-Cylinder (FW)	159 (4050)	113.4 (2880)	192.5 (4890)	204.7 (5200)	78.3 (1990)	61 (1550)	5	10	8000 (3640)
	120 (3050)	92.9 (2360)	153.1 (3890)	165.4 (4200)	57.9 (1470)	45.7 (1160)	5	10	8000 (3640)
	132 (3350)	98.4 (2500)	165 (4190)	177.2 (4500)	63.4 (1610)	48.8 (1240)	5	10	8000 (3640)
	147.5 (3750)	108.3 (2750)	180.7 (4590)	192.9 (4900)	73.2 (1860)	51.2 (1300)	5	10	8000 (3640)
Full Free-Lift 3-Stage (FSV)	159 (4050)	113.4 (2880)	192.5 (4890)	204.7 (5200)	78.3 (1990)	61 (1550)	5	10	8000 (3640)
	175 (4450)	92.9 (2360)	208.3 (5290)	220.5 (5600)	57.9 (1470)	45.7 (1160)	5	6	8000 (3640)
	187 (4750)	96.1 (2440)	220.1 (5590)	232.3 (5900)	61 (1550)	48.8 (1240)	5	6	8000 (3640)
	199 (5050)	98.4 (2500)	231.9 (5890)	244.1 (6200)	63.4 (1610)	51.2 (1300)	5	6	8000 (3640)
	218.5 (5550)	108.3 (2750)	251.6 (6390)	263.8 (6700)	73.2 (1860)	61 (1550)	5	6	7716 (3500)
	238 (6050)	113.4 (2880)	271.3 (6890)	283.5 (7200)	78.3 (1990)	66.1 (1680)	5	6	7430 (3370)
	258 (6550)	123.2 (3130)	290.9 (7390)	303.1 (7700)	88.2 (2240)	76 (1930)	5	6	6812 (3090)
Full Free-Lift 3-Stage, 4-Cylinder (FSW)	175 (4450)	92.9 (2360)	208.3 (5290)	220.5 (5600)	57.9 (1470)	45.7 (1160)	5	6	8000 (3640)
	187 (4750)	96.1 (2440)	220.1 (5590)	232.3 (5900)	61 (1550)	48.8 (1240)	5	6	8000 (3640)
	199 (5050)	98.4 (2500)	231.9 (5890)	244.1 (6200)	63.4 (1610)	51.2 (1300)	5	6	8000 (3640)
	218.5 (5550)	108.3 (2750)	251.6 (6390)	263.8 (6700)	73.2 (1860)	61 (1550)	5	6	7716 (3500)
	238 (6050)	113.4 (2880)	271.3 (6890)	283.5 (7200)	78.3 (1990)	66.1 (1680)	5	6	7430 (3370)
	258 (6550)	123.2 (3130)	290.9 (7390)	303.1 (7700)	88.2 (2240)	76 (1930)	5	6	6812 (3090)

MAST TYPE	MAXIMUM FORK HEIGHT (TOP OF FORKS)	OVERALL HEIGHT			FREE-LIFT		TILT RANGE		LOAD CAPACITY AT
		LOWERED	EXTENDED		WITHOUT LOAD BACKREST	WITH STANDARD LOAD BACKREST <sup>1</sup>	FWD	BWD	24 IN. (610 MM) LOAD CENTER*
			WITHOUT LOAD BACKREST	WITH STANDARD LOAD BACKREST <sup>1</sup>					lb (kg)
	in (mm)	in (mm)	in (mm)	in (mm)	in (mm)	in (mm)	deg	deg	lb (kg)
<b>8FBM45T</b>									
Wide Visible (V)	120 (3050)	92.9 (2360)	151.8 (3856)	165.4 (4200)	3.15 (80)	3.15 (80)	5	10	9000 (4090)
	132 (3350)	98.4 (2500)	163.6 (4156)	177.2 (4500)	3.15 (80)	3.15 (80)	5	10	9000 (4090)
	147.5 (3750)	108.3 (2750)	179.5 (4560)	192.9 (4900)	3.15 (80)	3.15 (80)	5	10	9000 (4090)
	159 (4050)	113.4 (2880)	191.2 (4856)	204.7 (5200)	3.15 (80)	3.15 (80)	5	10	9000 (4090)
	179 (4550)	123.2 (3130)	210.9 (5356)	224.4 (5700)	3.15 (80)	3.15 (80)	5	6	9000 (4090)
	199 (5050)	133.1 (3380)	230.6 (5856)	244.1 (6200)	3.15 (80)	3.15 (80)	5	6	9000 (4090)
Full Free-Lift 2-Stage (FV)	218.5 (5550)	142.9 (3630)	250.2 (6356)	263.8 (6700)	3.15 (80)	3.15 (80)	5	6	8928 (4050)
	120 (3050)	92.9 (2360)	153.1 (3890)	165.4 (4200)	57.9 (1470)	45.7 (1160)	5	10	9000 (4090)
	132 (3350)	98.4 (2500)	165 (4190)	177.2 (4500)	63.4 (1610)	48.8 (1240)	5	10	9000 (4090)
	147.5 (3750)	108.3 (2750)	180.7 (4590)	192.9 (4900)	73.2 (1860)	51.2 (1300)	5	10	9000 (4090)
Full Free-Lift 2-Stage, 4-Cylinder (FW)	159 (4050)	113.4 (2880)	192.5 (4890)	204.7 (5200)	78.3 (1990)	61 (1550)	5	10	9000 (4090)
	120 (3050)	92.9 (2360)	153.1 (3890)	165.4 (4200)	57.9 (1470)	45.7 (1160)	5	10	9000 (4090)
	132 (3350)	98.4 (2500)	165 (4190)	177.2 (4500)	63.4 (1610)	48.8 (1240)	5	10	9000 (4090)
	147.5 (3750)	108.3 (2750)	180.7 (4590)	192.9 (4900)	73.2 (1860)	51.2 (1300)	5	10	9000 (4090)
Full Free-Lift 3-Stage (FSV)	159 (4050)	113.4 (2880)	192.5 (4890)	204.7 (5200)	78.3 (1990)	61 (1550)	5	10	9000 (4090)
	175 (4450)	92.9 (2360)	208.3 (5290)	220.5 (5600)	57.9 (1470)	45.7 (1160)	5	6	9000 (4090)
	187 (4750)	96.1 (2440)	220.1 (5590)	232.3 (5900)	61 (1550)	48.8 (1240)	5	6	9000 (4090)
	199 (5050)	98.4 (2500)	231.9 (5890)	244.1 (6200)	63.4 (1610)	51.2 (1300)	5	6	8818 (4000)
	218.5 (5550)	108.3 (2750)	251.6 (6390)	263.8 (6700)	73.2 (1860)	61 (1550)	5	6	8708 (3950)
	238 (6050)	113.4 (2880)	271.3 (6890)	283.5 (7200)	78.3 (1990)	66.1 (1680)	5	6	8443 (3830)
	258 (6550)	123.2 (3130)	290.9 (7390)	303.1 (7700)	88.2 (2240)	76 (1930)	5	6	7319 (3320)
Full Free-Lift 3-Stage, 4-Cylinder (FSW)	175 (4450)	92.9 (2360)	208.3 (5290)	220.5 (5600)	57.9 (1470)	45.7 (1160)	5	6	9000 (4090)
	187 (4750)	96.1 (2440)	220.1 (5590)	232.3 (5900)	61 (1550)	48.8 (1240)	5	6	9000 (4090)
	199 (5050)	98.4 (2500)	231.9 (5890)	244.1 (6200)	63.4 (1610)	51.2 (1300)	5	6	8818 (4000)
	218.5 (5550)	108.3 (2750)	251.6 (6390)	263.8 (6700)	73.2 (1860)	61 (1550)	5	6	8708 (3950)
	238 (6050)	113.4 (2880)	271.3 (6890)	283.5 (7200)	78.3 (1990)	66.1 (1680)	5	6	8443 (3830)
	258 (6550)	123.2 (3130)	290.9 (7390)	303.1 (7700)	88.2 (2240)	76 (1930)	5	6	7319 (3320)

<sup>1</sup> Height of standard load backrest is 48" (1220 mm).  
\* All capacities of 1500 lbs. or less are subject to a secondary review by Toyota.

## MAST SPECIFICATIONS

MAST TYPE	MAXIMUM FORK HEIGHT (TOP OF FORKS)	OVERALL HEIGHT				FREE-LIFT		TILT RANGE		LOAD CAPACITY AT
		LOWERED	EXTENDED		WITHOUT LOAD BACKREST	WITH STANDARD LOAD BACKREST <sup>1</sup>	FWD	BWD	24 IN. (610 MM)	
			WITHOUT LOAD BACKREST	WITH STANDARD LOAD BACKREST <sup>1</sup>					LOAD CENTER <sup>2</sup>	
			in (mm)	in (mm)					lb (kg)	
<b>8FBM50T</b>										
Wide Visible (V)	120 (3060)	92.9 (2360)	155.7 (3956)	165.4 (4200)	3.15 (80)	3.15 (80)	5	10	11000 (4990)	
	132 (3360)	98.4 (2500)	163.6 (4156)	177.2 (4500)	3.15 (80)	3.15 (80)	5	10	11000 (4990)	
	148 (3760)	108.3 (2750)	179.5 (4560)	192.9 (4900)	3.15 (80)	3.15 (80)	5	10	11000 (4990)	
	160 (4060)	113.4 (2880)	191.2 (4856)	204.7 (5200)	3.15 (80)	3.15 (80)	5	10	11000 (4990)	
	179.5 (4560)	123.2 (3130)	210.9 (5356)	224.4 (5700)	3.15 (80)	3.15 (80)	5	6	11000 (4990)	
	199 (5060)	133.1 (3380)	230.6 (5856)	244.1 (6200)	3.15 (80)	3.15 (80)	5	6	11000 (4990)	
Full Free-Lift 2-Stage (FV)	219 (5560)	142.9 (3630)	250.2 (6356)	263.8 (6700)	3.15 (80)	3.15 (80)	5	6	10913 (4950)	
	112.5 (2860)	92.9 (2360)	145.3 (3690)	157.5 (4000)	57.9 (1470)	45.7 (1160)	5	10	11000 (4990)	
	132 (3360)	103.5 (2630)	165 (4190)	177.2 (4500)	68.5 (1740)	56.3 (1430)	5	10	11000 (4990)	
	148 (3760)	113.4 (2880)	180.7 (4590)	192.9 (4900)	78.3 (1990)	66.1 (1680)	5	10	11000 (4990)	
Full Free-Lift 4-Cylinder (FW)	160 (4060)	123.2 (3130)	192.5 (4890)	204.7 (5200)	88.2 (2240)	76 (1930)	5	10	11000 (4990)	
	112.5 (2860)	92.9 (2360)	145.3 (3690)	157.5 (4000)	57.9 (1470)	45.7 (1160)	5	10	11000 (4990)	
	132 (3360)	103.5 (2630)	165 (4190)	177.2 (4500)	68.5 (1740)	56.3 (1430)	5	10	11000 (4990)	
Full Free-Lift 3-Stage (FSV)	148 (3760)	113.4 (2880)	180.7 (4590)	192.9 (4900)	78.3 (1990)	66.1 (1680)	5	10	11000 (4990)	
	160 (4060)	123.2 (3130)	192.5 (4890)	204.7 (5200)	88.2 (2240)	76 (1930)	5	10	11000 (4990)	
	171.5 (4360)	92.9 (2360)	204.3 (5190)	216.5 (5500)	57.9 (1470)	45.7 (1160)	5	6	11000 (4990)	
	187 (4760)	98.4 (2500)	220.1 (5590)	232.3 (5900)	63.4 (1610)	51.2 (1300)	5	6	10957 (4970)	
	199 (5060)	103.5 (2630)	231.9 (5890)	244.1 (6200)	68.5 (1740)	56.3 (1430)	5	6	10780 (4890)	
Full Free-Lift 4-Cylinder (FSW)	219 (5560)	113.4 (2880)	251.6 (6390)	263.8 (6700)	78.3 (1990)	66.1 (1680)	5	6	10471 (4750)	
	238.5 (6060)	123.2 (3130)	271.3 (6890)	283.5 (7200)	88.2 (2240)	76 (1930)	5	6	10163 (4610)	
	258 (6560)	133.1 (3380)	290.9 (7390)	303.1 (7700)	98 (2490)	85.8 (2180)	5	6	8488 (3850)	
	171.5 (4360)	92.9 (2360)	204.3 (5190)	216.5 (5500)	57.9 (1470)	45.7 (1160)	5	6	11000 (4990)	
	187 (4760)	98.4 (2500)	220.1 (5590)	232.3 (5900)	63.4 (1610)	51.2 (1300)	5	6	10957 (4970)	

<sup>1</sup> Height of standard load backrest is 48" (1220 mm).  
<sup>2</sup> All capacities of 1500 lbs. or less are subject to a secondary review by Toyota.

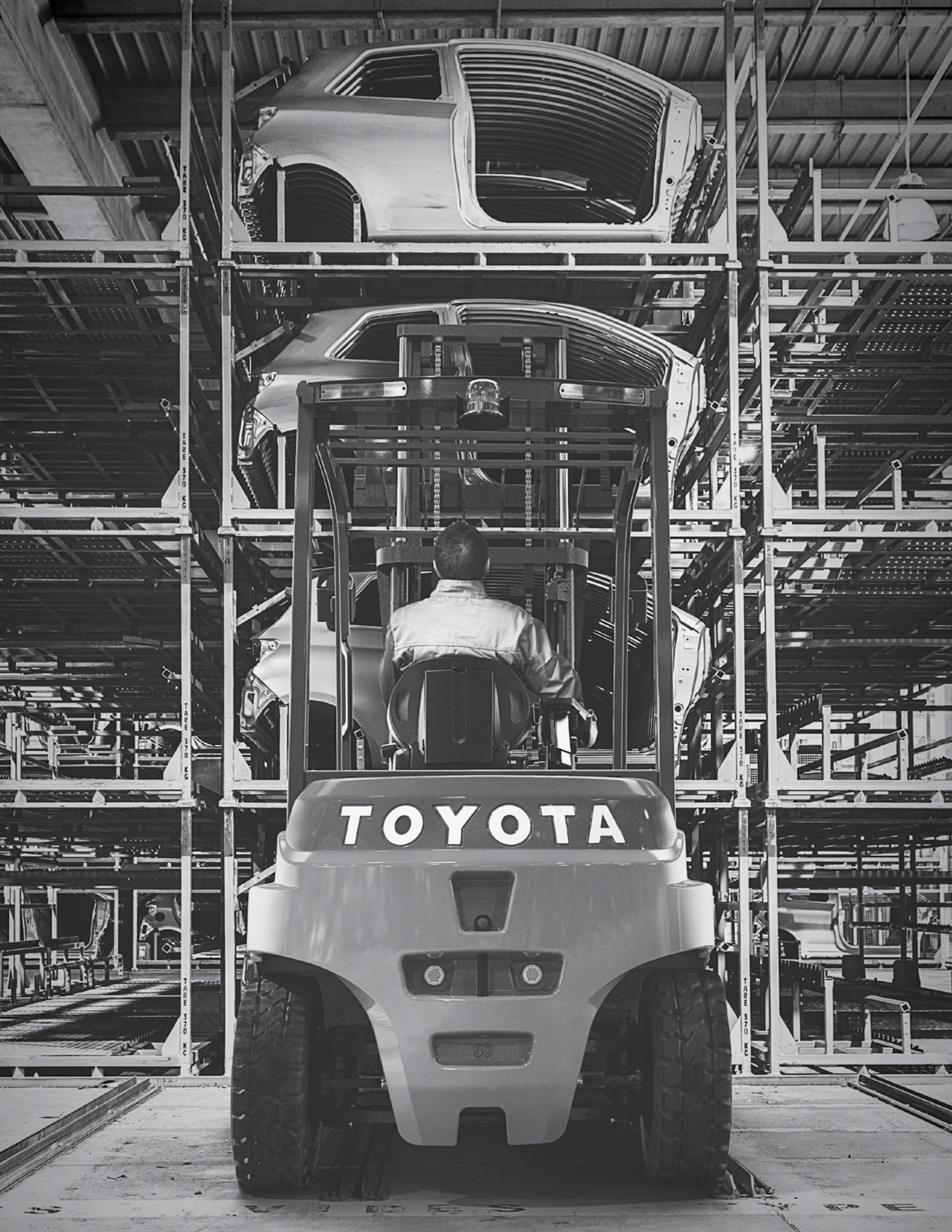



# “I’M HERE TO MAKE SURE YOUR FORKLIFTS DON’T TAKE VACATION DAYS.”

Butch - 360 Technician, ProLift, Cincinnati, Ohio



## HELP IS ALWAYS HERE WITH TOYOTA 360 SUPPORT.

The industry’s best and most comprehensive dealer network quickly delivers Toyota Certified Technicians to your work site. These specially-trained technicians can also help assess your warehouse and facility needs to recommend the right equipment for the job. And with the largest fleet of used and rental forklifts, Toyota 360 keeps your business running at full speed.

[ToyotaForklift.com/360-Support](http://ToyotaForklift.com/360-Support)



**YOUR BUSINESS IS RIDING ON IT.**

Some product features described herein are optional. Please consult your dealer for specifications. Details of specifications and equipment are based on information available at time of printing and may change without notice.

