

MID IC PNEUMATIC



8000 - 11000 LBS.

SPECIFICATIONS



50-8FG35U-50U

CLASS
5

INTERNAL COMBUSTION ENGINE PNEUMATIC TIRE

ToyotaForklift.com

MID IC PNEUMATIC

CAPACITY
8000 – 11000 LBS.

MAXIMUM FORK HEIGHT
239 IN.

LOAD CENTER
24 IN.

INDUSTRIES



Brick, Block
& Pipe



Distribution



Factory



General
Manufacturing



General
Warehousing



Lumber



Paper



Retail

STANDARD FEATURES

DURABILITY

- Control Area Network (CAN-bus) communication
- Fully stamped steel side panels
- Full-floating front axle
- Moisture-resistant electric connectors
- Limited free-lift 2-stage mast (V)
- High cooling capacity radiator
- Tilt cylinder boots
- Low-maintenance battery
- Large-capacity engine-cooling fan
- 8" cyclone air cleaner
- Plate-iron front fenders
- Anti-restart ignition key switch
- Stamped steel engine hood
- Radiator screen
- External hydraulic oil cooler
- Force-cooled wet disc brakes
- Fully oil charged lift cylinder

SUPPORT

- System of Active Stability™ (SAS)
- Operator Presence Sensing System (OPSS)
- Bolt-on overhead guard
- Key lowering interlock
- Electric horn
- Neutral start safety switch
- Asbestos-free components
- Orange forks
- LED headlights
- Key off/headlight off system
- Speed control

PERFORMANCE

- EPA/CARB-certified engine
- UL-approved model type "LP"
- 4-cylinder, 3.7 liter, OHV LP engine (1FS)
- 2 speed automatic (powershift) transmission
 - 2FWD/2REV speeds
 - Electronically controlled
- LCD multi-function display – includes:
 - Data log, fuel, and operation information with QR code output
 - Master warning, wheel, direction, and mast tilt indicators
 - Various hours meters
 - Engine coolant temperature gauge
 - Fuel gauge (excluding LP)
 - Check engine light
 - Engine oil pressure warning light
 - Parking brake indicator
 - SAS/OPSS warning light
- Alternator with built-in regulator
 - LP model = 70A
- Automatic transmission with oil cooler
- Full-floating powertrain
- Treaded pneumatic tires (front & rear)
- Wide tread
- 1st gear lock switch on steering column
- Distributorless ignition system (1FS)

ERGONOMICS

- 11.8"-dia., two-spoke steering wheel
- Load-sensing power steering
- One-way automatic fork leveling
- Double-action parking brake (hand)
- Integrated headlight & turn signal lever
- Cowl-mounted hydraulic control levers with rubber boot covers
- 12" long dual operator assist grips
- Low, wide entry steps
- Dash-integrated amenity tray & oversized cup holder
- Premium Comfort Seat
- Non-cinching seatbelt
- Dash mounted instrument display

SERVICEABILITY

- Easy-access no tools required floorboard
- Engine hood assist damper with lock device
- Engine protection system
- Air cleaner discharge valve
- Easy-lift engine hood with wide 75° opening
- Easy access to common service items such as filters & dipsticks

Please contact your local, authorized Toyota Dealer for a complete list of available options.

TRUCK SPECIFICATIONS

MODEL NUMBERS

GENERAL DATA				50-8FG35U	50-8FG40U
Load Capacity	lb (kg)			8000 (3500)	9000 (4000)
Power Type				LP	LP
Operator Position				Seated Rider	Seated Rider
Tire Type	Front / Rear			Pneumatic / Pneumatic	Pneumatic / Pneumatic
Wheels (x = driven)	Front / Rear			2x / 2	2x / 2
EXTERIOR DIMENSIONS				50-8FG35U	50-8FG40U
A Maximum Fork Height (top of forks)	in (mm)			120 (3050)	120 (3050)
B Free-Lift (top of forks)	in (mm)			4.3 (110)	4.3 (110)
C Fork Size (T x W x L)	in (mm)			2 x 6 x 42 (50 x 150 x 1070)	2 x 6 x 42 (50 x 150 x 1070)
D Fork Spread Max. / Min. (outer edge to edge)	in (mm)			46.1 / 11.8 (1170 / 300)	46.1 / 11.8 (1170 / 300)
E Tilt Range (forward / backward)	deg			6 / 12	6 / 12
F Length to Fork Face	in (mm)			115.2 (2925)	117.3 (2980)
G Overall Width	in (mm)			53.1 (1350)	53.1 (1350)
H Mast Lowered Height	in (mm)			83 (2110)	83 (2110)
I Mast Extended Height (top of load backrest)	in (mm)			168.1 (4270)	168.1 (4270)
J Overhead Guard Height	in (mm)			87 (2210)	87 (2210)
K Turning Radius (inside / outside)	in (mm)			103 (2610)	104.5 (2660)
L Load Distance ¹	in (mm)			19.9 (505)	19.9 (505)
M Basic Right-Angle Stacking Aisle Width	in (mm)			122.5 (3120)	124.5 (3170)
PERFORMANCE DATA				50-8FG35U	50-8FG40U
Speeds	Maximum Travel (forward / reverse)	Full Load	mph (km/h)	13.7 (22.0) / 13.7 (22.0)	13.7 (22.0) / 13.7 (22.0)
		No Load	mph (km/h)	15.0 (24.0) / 15.0 (24.0)	15.0 (24.0) / 15.0 (24.0)
	Lifting	Full Load	fpm (mm/sec)	103 (525)	103 (525)
		No Load	fpm (mm/sec)	108 (550)	108 (550)
	Lowering	Full Load	fpm (mm/sec)	104 (530)	104 (530)
		No Load	fpm (mm/sec)	94 (480)	94 (480)
Drawbar Pull	Maximum	Full Load	lb (kg)	7900 (3600)	7900 (3600)
		No Load	lb (kg)	3200 (1450)	3090 (1400)
Gradeability	1 mph (1.5 km/h) ²	Full Load	%	32	29
		Full Load	%	42	38
	Maximum ²	No Load	%	24	21
TRUCK WEIGHTS				50-8FG35U	50-8FG40U
Total Weight	lb (kg)			12860 (5840)	13680 (6210)
Weight Distribution	Full Load (front / rear)	lb (kg)		18070 (8200) / 2510 (1140)	19650 (8920) / 2840 (1290)
	No Load (front / rear)	lb (kg)		5850 (2660) / 7010 (3180)	5700 (2590) / 7980 (3620)
TIRES				50-8FG35U	50-8FG40U
Tires	Number (front / rear)			2 / 2	2 / 2
	Size	Front		250-15-18PR	250-15-18PR
		Rear		7.00-12-12PR	7.00-12-12PR
Wheelbase	in (mm)			74.8 (1900)	74.8 (1900)
Tread Width (front / rear)	in (mm)			43.9 (1115) / 43.3 (1100)	43.9 (1115) / 43.3 (1100)
Underclearance (full load)	Minimum with Load	in (mm)		4.7 (120)	4.7 (120)
	Center of Wheelbase	in (mm)		7.9 (200)	7.9 (200)
Brake	Service (foot) / Parking			Hydraulic <wet> / Hand	Hydraulic <wet> / Hand
POWER SYSTEM				50-8FG35U	50-8FG40U
Battery (5-hour rating)	V / Ah			12 / 35	12 / 35
Internal Combustion Engine	Make / Model			1FS	1FS
	Rated Horsepower @ rpm	SAE HP		87@2330	87@2330
		(kW)		65@2330	65@2330
	Rated Torque @ rpm	SAE ft-lb		212@1600	212@1600
		(N-m)		288@1600	288@1600
	Number of Cylinders			4	4
Piston Displacement	cu in (cc)		224 (3685)	224 (3685)	
Fuel Tank Capacity	US gal (liter)		24 (90)	24 (90)	
Transmission	Type			Powershift	Powershift
	Speeds (forward / reverse)			2 / 2	2 / 2
Auxiliary Hydraulic Function Specifications (for attachments) ³	Max. Operating Pressure	psi (kg/cm ²)		2630 (185)	2630 (185)
	Max. Flow Rate	gpm (lpm)		33.8 (128)	33.8 (128)

¹ Centerline of front axle to front face of forks.

² Computed values.

³ Values taken at Hydraulic Control Valve. Does not take into consideration losses through mast plumbing (hosing, fittings, QO's, etc.).

TRUCK SPECIFICATIONS

MODEL NUMBERS

GENERAL DATA				50-8FG45U	50-8FG50U
Load Capacity		lb (kg)		10000 (4500)	11000 (5000)
Power Type				LP	LP
Operator Position				Seated Rider	Seated Rider
Tire Type	Front / Rear			Pneumatic / Pneumatic	Pneumatic / Pneumatic
Wheels (x = driven)	Front / Rear			2x / 2	2x / 2
EXTERIOR DIMENSIONS				50-8FG45U	50-8FG50U
A Maximum Fork Height (top of forks)		in (mm)		120 (3050)	120.5 (3060)
B Free-Lift (top of forks)		in (mm)		4.3 (110)	4.7 (120)
C Fork Size (T x W x L)		in (mm)		2 x 6 x 42 (50 x 150 x 1070)	2.4 x 6 x 48 (60 x 150 x 1220)
D Fork Spread Max. / Min. (outer edge to edge)		in (mm)		45.7 / 11.8 (1160 / 300)	45.7 / 11.8 (1160 / 300)
E Tilt Range (forward / backward)		deg		6 / 12	6 / 12
F Length to Fork Face		in (mm)		122.4 (3110)	124.8 (3170)
G Overall Width		in (mm)		57.1 (1450)	57.1 (1450)
H Mast Lowered Height		in (mm)		86.5 (2200)	96.5 (2450)
I Mast Extended Height (top of load backrest)		in (mm)		168.1 (4270)	174.6 (4435)
J Overhead Guard Height		in (mm)		90.6 (2300)	90.6 (2300)
K Turning Radius (inside / outside)		in (mm)		108.5 (2750)	110.5 (2810)
L Load Distance ¹		in (mm)		21.5 (545)	21.9 (555)
M Basic Right-Angle Stacking Aisle Width		in (mm)		129.5 (3300)	132.5 (3370)
PERFORMANCE DATA				50-8FG45U	50-8FG50U
Speeds	Maximum Travel (forward / reverse)	Full Load	mph (km/h)	13.7 (22.0) / 13.7 (22.0)	13.7 (22.0) / 113.7 (22.0)
		No Load	mph (km/h)	15.0 (24.0) / 15.0 (24.0)	15.0 (24.0) / 15.0 (24.0)
	Lifting	Full Load	fpm (mm/sec)	94 (480)	94 (480)
		No Load	fpm (mm/sec)	102 (520)	102 (520)
	Lowering	Full Load	fpm (mm/sec)	106 (540)	106 (540)
		No Load	fpm (mm/sec)	96 (490)	96 (490)
Drawbar Pull	Maximum	Full Load	lb (kg)	7900 (3600)	7900 (3600)
		No Load	lb (kg)	3570 (1620)	3770 (1710)
Gradeability	1 mph (1.5 km/h) ²	Full Load	%	26	24
		Full Load	%	34	31
	Maximum ²	No Load	%	22	21
TRUCK WEIGHTS				50-8FG45U	50-8FG50U
Total Weight		lb (kg)		14850 (6740)	16010 (7270)
Weight Distribution	Full Load (front / rear)	lb (kg)		22060 (10010) / 2710 (1230)	24220 (10990) / 2820 (1280)
	No Load (front / rear)	lb (kg)		6450 (2930) / 8400 (3810)	6820 (3100) / 9190 (4170)
TIRES				50-8FG45U	50-8FG50U
Tires	Number (front / rear)			2 / 2	2 / 2
	Size	Front		300-15-20PR	300-15-20PR
		Rear		7.00-12-12PR	7.00-12-14PR
Wheelbase		in (mm)		78.7 (2000)	78.7 (2000)
Tread Width (front / rear)		in (mm)		45.3 (1150) / 43.3 (1100)	45.3 (1150) / 43.3 (1100)
Underclearance (full load)	Minimum with Load	in (mm)		4.7 (120)	4.7 (120)
	Center of Wheelbase	in (mm)		9.1 (230)	9.1 (230)
Brake	Service (foot) / Parking			Hydraulic <wet> / Hand	Hydraulic <wet> / Hand
POWER SYSTEM				50-8FG45U	50-8FG50U
Battery (5-hour rating)		V / Ah		12 / 35	12 / 35
Internal Combustion Engine	Make / Model			1FS	1FS
	Rated Horsepower @ rpm	SAE HP		87@2330	87@2330
		(kW)		65@2330	65@2330
	Rated Torque @ rpm	SAE ft-lb		212@1600	212@1600
		(N-m)		288@1600	288@1600
	Number of Cylinders			4	4
Piston Displacement		cu in (cc)		224 (3685)	224 (3685)
Fuel Tank Capacity		US gal (liter)		32 (120)	32 (120)
Transmission	Type			Powershift	Powershift
	Speeds (forward / reverse)			2 / 2	2 / 2
Auxiliary Hydraulic Function Specifications (for attachments) ³	Max. Operating Pressure	psi (kg/cm ²)		2630 (185)	2630 (185)
	Max. Flow Rate	gpm (lpm)		33.8 (128)	33.8 (128)

1 Centerline of front axle to front face of forks.

2 Computed values.

3 Values taken at Hydraulic Control Valve. Does not take into consideration losses through mast plumbing (hosing, fittings, QQ's, etc.).

EXTERIOR DIMENSIONS

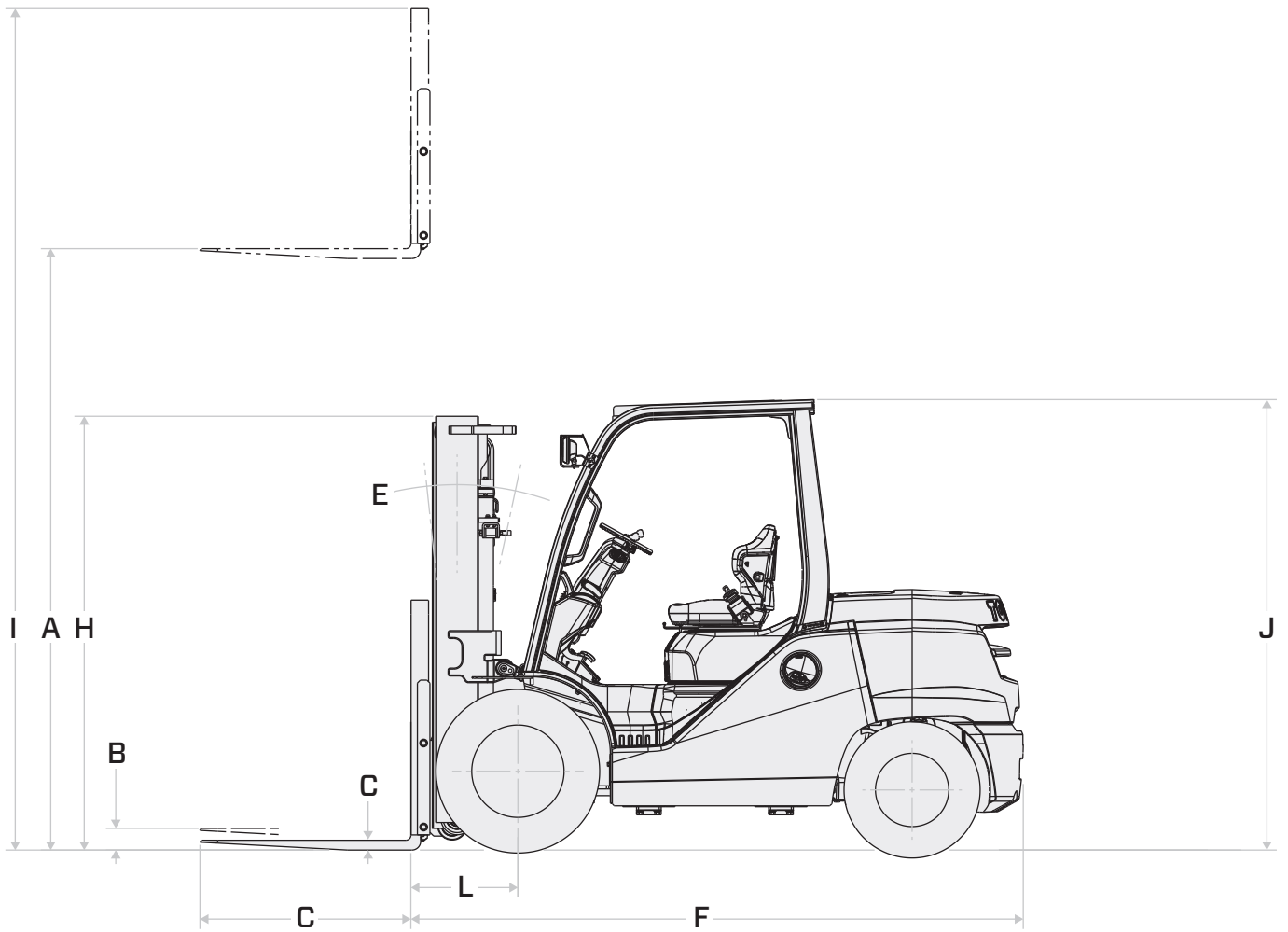
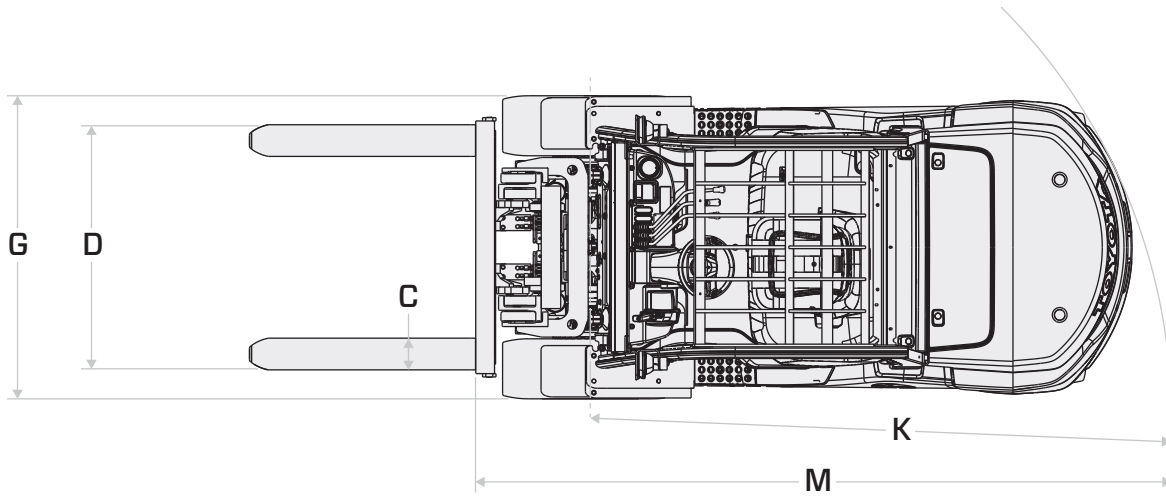

MAST SPECIFICATIONS

MAST TYPE	MAXIMUM FORK HEIGHT (TOP OF FORKS)	OVERALL HEIGHT			FREE-LIFT		SINGLE TIRE			DUAL TIRE		
		LOWERED	EXTENDED		WITHOUT LOAD BACKREST	WITH STANDARD LOAD BACKREST ¹	TILT RANGE		LOAD CAPACITY AT 24 IN. (610 MM) LOAD CENTER	TILT RANGE		LOAD CAPACITY AT 24 IN. (610 MM) LOAD CENTER
			WITHOUT LOAD BACKREST	WITH STANDARD LOAD BACKREST ¹			FWD	BWD		FWD	BWD	
	in (mm)	in (mm)	in (mm)	in (mm)	in (mm)	in (mm)	deg	deg	lb (kg)	deg	deg	lb (kg)
50-8FG35U												
Wide Visible (V)	120 (3050)	83.1 (2110)	151.6 (3850)	168.1 (4270)	4.3 (110)	4.3 (110)	6	12	8000 (3500)	6	12	8000 (3500)
	132 (3350)	90.2 (2290)	163.4 (4150)	179.9 (4570)	4.3 (110)	4.3 (110)	6	12	8000 (3500)	6	12	8000 (3500)
	147.5 (3750)	98 (2490)	179.1 (4550)	195.7 (4970)	4.3 (110)	4.3 (110)	6	12	8000 (3500)	6	12	8000 (3500)
	159.5 (4050)	107.9 (2740)	190.9 (4850)	207.5 (5270)	4.3 (110)	4.3 (110)	6	12	8000 (3500)	6	12	8000 (3500)
	179 (4550)	117.7 (2990)	210.6 (5350)	227.2 (5770)	4.3 (110)	4.3 (110)	6	12	8000 (3500)	6	12	8000 (3500)
Full Free-Lift 2-Stage (FV)	120 (3050)	83.1 (2110)	152.8 (3880)	168.1 (4270)	50.4 (1280)	35 (890)	6	12	8000 (3500)	6	12	8000 (3500)
	132 (3350)	90.2 (2290)	164.6 (4180)	179.9 (4570)	57.5 (1460)	42.1 (1070)	6	12	8000 (3500)	6	12	8000 (3500)
Full Free-Lift 3-Stage (FSV)	159.5 (4050)	83.1 (2110)	192.1 (4880)	207.5 (5270)	50.4 (1280)	35 (890)	6	6	8000 (3500)	6	6	8000 (3500)
	171.5 (4350)	85 (2160)	203.9 (5180)	219.3 (5570)	52.4 (1330)	37 (940)	6	6	8000 (3500)	6	6	8000 (3500)
	187 (4750)	90.2 (2290)	219.7 (5580)	235 (5970)	57.5 (1460)	42.1 (1070)	6	6	7700 (3500)	6	6	7700 (3500)
	199 (5050)	94.1 (2390)	231.5 (5880)	246.9 (6270)	61.4 (1560)	46.1 (1170)	6	6	7500 (3400)	6	6	7500 (3400)
	218.5 (5550)	100 (2540)	251.2 (6380)	266.5 (6770)	67.3 (1710)	52 (1320)	6	6	6200 (2800)	6	6	7250 (3300)
238 (6050)	107.9 (2740)	270.9 (6880)	286.2 (7270)	75.2 (1910)	59.8 (1520)	6	6	4600 (2100)	6	6	7050 (3200)	

MAST TYPE	MAXIMUM FORK HEIGHT (TOP OF FORKS)	OVERALL HEIGHT			FREE-LIFT		SINGLE TIRE			DUAL TIRE		
		LOWERED	EXTENDED		WITHOUT LOAD BACKREST	WITH STANDARD LOAD BACKREST ¹	TILT RANGE		LOAD CAPACITY AT 24 IN. (610 MM) LOAD CENTER	TILT RANGE		LOAD CAPACITY AT 24 IN. (610 MM) LOAD CENTER
			WITHOUT LOAD BACKREST	WITH STANDARD LOAD BACKREST ¹			FWD	BWD		FWD	BWD	
	in (mm)	in (mm)	in (mm)	in (mm)	in (mm)	in (mm)	deg	deg	lb (kg)	deg	deg	lb (kg)
50-8FG40U												
Wide Visible (V)	120 (3050)	83.1 (2110)	151.6 (3850)	168.1 (4270)	4.3 (110)	4.3 (110)	6	12	9000 (4000)	6	12	9000 (4000)
	132 (3350)	90.2 (2290)	163.4 (4150)	179.9 (4570)	4.3 (110)	4.3 (110)	6	12	9000 (4000)	6	12	9000 (4000)
	147.5 (3750)	98 (2490)	179.1 (4550)	195.7 (4970)	4.3 (110)	4.3 (110)	6	12	9000 (4000)	6	12	9000 (4000)
	159.5 (4050)	107.9 (2740)	190.9 (4850)	207.5 (5270)	4.3 (110)	4.3 (110)	6	12	9000 (4000)	6	12	9000 (4000)
	179 (4550)	117.7 (2990)	210.6 (5350)	227.2 (5770)	4.3 (110)	4.3 (110)	6	6	9000 (4000)	6	12	9000 (4000)
Full Free-Lift 2-Stage (FV)	120 (3050)	83.1 (2110)	152.8 (3880)	168.1 (4270)	50.4 (1280)	35 (890)	6	12	9000 (4000)	6	12	9000 (4000)
	132 (3350)	90.2 (2290)	164.6 (4180)	179.9 (4570)	57.5 (1460)	42.1 (1070)	6	12	9000 (4000)	6	12	9000 (4000)
Full Free-Lift 3-Stage (FSV)	159.5 (4050)	83.1 (2110)	192.1 (4880)	207.5 (5270)	50.4 (1280)	35 (890)	6	6	9000 (4000)	6	6	9000 (4000)
	171.5 (4350)	85 (2160)	203.9 (5180)	219.3 (5570)	52.4 (1330)	37 (940)	6	6	9000 (4000)	6	6	9000 (4000)
	187 (4750)	90.2 (2290)	219.7 (5580)	235 (5970)	57.5 (1460)	42.1 (1070)	6	6	9000 (4000)	6	6	9000 (4000)
	199 (5050)	94.1 (2390)	231.5 (5880)	246.9 (6270)	61.4 (1560)	46.1 (1170)	6	6	9000 (4000)	6	6	9000 (4000)
	218.5 (5550)	100 (2540)	251.2 (6380)	266.5 (6770)	67.3 (1710)	52 (1320)	6	6	7700 (3500)	6	6	9000 (4000)
238 (6050)	107.9 (2740)	270.9 (6880)	286.2 (7270)	75.2 (1910)	59.8 (1520)	6	6	5950 (2700)	6	6	7280 (3300)	

¹ Height of standard load backrest is 48" (1220 mm).

MAST TYPE	MAXIMUM FORK HEIGHT (TOP OF FORKS)	OVERALL HEIGHT			FREE-LIFT		SINGLE TIRE			DUAL TIRE		
		LOWERED	EXTENDED		WITHOUT LOAD BACKREST	WITH STANDARD LOAD BACKREST ¹	TILT RANGE		LOAD CAPACITY AT 24 IN. (610 MM) LOAD CENTER	TILT RANGE		LOAD CAPACITY AT 24 IN. (610 MM) LOAD CENTER
			WITHOUT LOAD BACKREST	WITH STANDARD LOAD BACKREST ¹			FWD	BWD		FWD	BWD	
		in (mm)	in (mm)	in (mm)	in (mm)	in (mm)	in (mm)	deg	deg	lb (kg)	deg	deg
50-8FG45U												
Wide Visible (V)	120 (3050)	86.6 (2200)	146.7 (3725)	168.1 (4270)	4.3 (110)	4.3 (110)	6	12	10000 (4500)	6	12	10000 (4500)
	132 (3350)	92.5 (2350)	158.5 (4025)	179.9 (4570)	4.3 (110)	4.3 (110)	6	12	10000 (4500)	6	12	10000 (4500)
	147.5 (3750)	102.4 (2600)	174.2 (4425)	195.7 (4970)	4.3 (110)	4.3 (110)	6	12	10000 (4500)	6	12	10000 (4500)
	159.5 (4050)	110.2 (2800)	186 (4725)	207.5 (5270)	4.3 (110)	4.3 (110)	6	12	10000 (4500)	6	12	10000 (4500)
	179 (4550)	120.1 (3050)	205.7 (5225)	227.2 (5770)	4.3 (110)	4.3 (110)	6	6	10000 (4500)	6	12	10000 (4500)
Full Free-Lift 2-Stage (FV)	120 (3050)	86.6 (2200)	147.2 (3740)	168.1 (4270)	59.5 (1510)	38.6 (980)	6	12	10000 (4500)	6	12	10000 (4500)
	132 (3350)	92.5 (2350)	159.1 (4040)	179.9 (4570)	65.4 (1660)	44.5 (1130)	6	12	10000 (4500)	6	12	10000 (4500)
Full Free-Lift 3-Stage (FSV)	159.5 (4050)	83.5 (2120)	186.8 (4745)	207.5 (5270)	56.3 (1430)	35.4 (900)	6	6	10000 (4500)	6	6	10000 (4500)
	171.5 (4350)	86.6 (2200)	198.6 (5045)	219.3 (5570)	59.5 (1510)	38.6 (980)	6	6	9750 (4500)	6	6	9750 (4500)
	187 (4750)	92.5 (2350)	214.4 (5445)	235 (5970)	65.4 (1660)	44.5 (1130)	6	6	9300 (4200)	6	6	9700 (4400)
	199 (5050)	96.5 (2450)	226.2 (5745)	246.9 (6270)	69.3 (1760)	48.4 (1230)	6	6	8800 (4000)	6	6	9450 (4300)
	218.5 (5550)	102.4 (2600)	245.9 (6245)	266.5 (6770)	75.2 (1910)	54.3 (1380)	6	6	6650 (3000)	6	6	9000 (4100)
238 (6050)	110.2 (2800)	265.6 (6745)	286.2 (7270)	83.1 (2110)	62.2 (1580)	6	6	5150 (2300)	6	6	8600 (3900)	

MAST TYPE	MAXIMUM FORK HEIGHT (TOP OF FORKS)	OVERALL HEIGHT			FREE-LIFT		SINGLE TIRE			DUAL TIRE		
		LOWERED	EXTENDED		WITHOUT LOAD BACKREST	WITH STANDARD LOAD BACKREST ²	TILT RANGE		LOAD CAPACITY AT 24 IN. (610 MM) LOAD CENTER	TILT RANGE		LOAD CAPACITY AT 24 IN. (610 MM) LOAD CENTER
			WITHOUT LOAD BACKREST	WITH STANDARD LOAD BACKREST ²			FWD	BWD		FWD	BWD	
		in (mm)	in (mm)	in (mm)	in (mm)	in (mm)	in (mm)	deg	deg	lb (kg)	deg	deg
50-8FG50U												
Wide Visible (V)	120.5 (3065)	96.5 (2450)	153.7 (3905)	174.6 (4435)	4.9 (125)	4.9 (125)	6	12	11000 (5000)	6	12	11000 (5000)
	132.5 (3365)	102.4 (2600)	165.6 (4205)	186.4 (4735)	4.9 (125)	4.9 (125)	6	12	11000 (5000)	6	12	11000 (5000)
	148 (3765)	110.2 (2800)	181.3 (4605)	202.2 (5135)	4.9 (125)	4.9 (125)	6	12	11000 (5000)	6	12	11000 (5000)
	160 (4065)	120.1 (3050)	193.1 (4905)	214 (5435)	4.9 (125)	4.9 (125)	6	12	11000 (5000)	6	12	11000 (5000)
	179.5 (4565)	129.9 (3300)	212.8 (5405)	233.7 (5935)	4.9 (125)	4.9 (125)	6	6	11000 (5000)	6	12	11000 (5000)
Full Free-Lift 3-Stage (FSV)	199.5 (5065)	139.8 (3550)	232.5 (5905)	253.4 (6435)	4.9 (125)	4.9 (125)	6	6	9000 (4000)	6	12	10600 (4800)
	160 (4065)	89.4 (2270)	194.3 (4935)	214 (5435)	55.1 (1400)	35.4 (900)	6	6	10800 (4900)	6	6	10800 (4900)
	172 (4365)	92.5 (2350)	206.1 (5235)	225.8 (5735)	58.3 (1480)	38.6 (980)	6	6	10600 (4800)	6	6	10600 (4800)
	187.5 (4765)	96.5 (2450)	221.9 (5635)	241.5 (6135)	62.2 (1580)	42.5 (1080)	6	6	9500 (4300)	6	6	10200 (4600)
	199.5 (5065)	102.4 (2600)	233.7 (5935)	253.4 (6435)	68.1 (1730)	48.4 (1230)	6	6	9000 (4100)	6	6	10000 (4500)
	219 (5565)	110.2 (2800)	253.4 (6435)	273 (6935)	76 (1930)	56.3 (1430)	6	6	6800 (3100)	6	6	9500 (4300)
239 (6065)	120.1 (3050)	273 (6935)	292.7 (7435)	85.8 (2180)	66.1 (1680)	6	6	5300 (2400)	6	6	9000 (4100)	

1 Height of standard load backrest is 48" (1220 mm).
2 Height of standard load backrest is 54" (1370 mm).



“I’M HERE TO MAKE SURE YOUR FORKLIFTS DON’T TAKE VACATION DAYS.”

Butch - 360 Technician, ProLift, Cincinnati, Ohio



HELP IS ALWAYS HERE WITH TOYOTA 360 SUPPORT.

The industry’s best and most comprehensive dealer network quickly delivers Toyota Certified Technicians to your work site. These specially trained technicians can also help assess your warehouse and facility needs to recommend the right equipment for the job. And with the largest fleet of material handling equipment, Toyota 360 keeps your business running at full speed.

ToyotaForklift.com/360-Support



YOUR BUSINESS IS RIDING ON IT.

Some product features described herein are optional. Please consult your dealer for specifications. Details of specifications and equipment are based on information available at time of printing and may change without notice. Photos may not reflect physical trucks.

