

# STAND-UP RIDER



3000 - 5000 LBS.

SPECIFICATIONS



8FBA15-25U

CLASS  
**1**

ELECTRIC MOTOR RIDERS

[ToyotaForklift.com](http://ToyotaForklift.com)

## STAND-UP RIDER

CAPACITY  
**3000 - 5000 LBS.**

LOAD CENTER  
**24 IN.**

MAXIMUM FORK HEIGHT  
**270.5 IN.**

### INDUSTRIES



Beverage



Factory



Food Storage



General Warehousing



Cold Storage



Food Processing



General Manufacturing



Retail

## STANDARD FEATURES

### PERFORMANCE

- 36 Volt Electrical System
- AC Induction Drive Motor
- Transistor Control System with MOSFET
- AC Induction Hydraulic Motor
- Independent Lift & Steer Motors
- Dual Polyurethane Steer Tires
- Low Durometer Smooth Rubber Drive Tires
- Power Hook-Up for Onboard Terminal, 10 Amp
- Programmable Performance Parameters
- Mast Tilt (3° fwd / 5° bwd)
- 7" Multifunction Color Touchscreen Display
- Load Weight, Mast Tilt, and Fork Height Indicators
- UL-E Construction
- Precision Load Stability System

### OPERABILITY

- Multifunction Control Handle (Single-Axis, Simultaneous Function)
- Electric Power Steering with Automatic Centering
- Auto-Off System
- Ventilated Tractor Compartment
- 2-Post Overhead Guard
- Auto-Position Hold (Drive Motor/Brake Hold)
- Anti-Stall Protection
- Extended Operator Backrest (60 inches)
- High Visibility Mast & Overhead Guard
- Dual Electric Disc Brakes (Self-Adjusting)
- Regenerative Plugging
- Proportional Plugging
- 48" Load Backrest
- Integral Sideshift (4" Each Way)
- 42" x 4" x 1.5" Forks

### ERGONOMICS

- Spacious Operator Compartment
- Flexible Sidestance Operator Compartment
- 7/8" Thick Bubble Cushioned Floor Mat
- Ergonomically Sloped Floorboard
- Comfort Ride Suspension Floor
- Cushioned Padded Backrest
- Low-Effort Brake Pedal
- Low Step Height
- Cushioned Padded Adjustable Armrest
- Integrated Clipboard, Amenity Tray & Cup Holder
- Cushioned Padded Adjustable Armrest
- Adjustable Tiller
- Knee Pad for Operator Lean Point
- Dual USB-A Ports

### SERVICEABILITY

- Tool Free Cover Removal - Front and Top Covers
- Self-Diagnostics (With Instructional Messages)
- Built-In Analyzer
- Fault Code Memory
- Programmable Maintenance Indicator
- Battery Retaining Gates
- Battery Compartment Rollers (Corrosion Resistant)
- Vertically Mounted Drive Motors
- Reverse Polarity Protection
- Anti-Static Ground Strap
- Flashware Enabled Software
- Battery Connector - SB350 Gray
- No Directional Contactors
- Multifunction Hour Meters
- Battery Discharge Indicator (With Lift Interrupt)
- Maintenance Indicator
- Temperature Indicator
- Visibility Channel for Operator Visibility to Forks & Drive Tire
- MyInsights® Telematics

## OPTIONAL EQUIPMENT

### LOAD HANDLING

- Full-Free Lift Three-Stage Mast (FSW)
- Full-Free Lift Four-Stage Mast (QFV)
- Full-Free Lift Four-Stage Mast (Narrow QFV)
- Tilt Cylinder Boots
- Mast Tilt (5° fwd / 3° bwd)
- Bottler's Tilt (10° fwd / 3° bwd)
- ISS Carriage Hose Guard
- 4th/5th Function
- Fixed Carriage
- Hydraulic Quick Disconnects (Single or Dual)
- Move Aux Function to Right Side of Carriage

### LOAD HANDLING (HOSE & VALVE ASSEMBLY) w/ SIDESHIFT

- No Aux with Sideshift
- Integral Sideshifting Fork Positioner
- Integral Sideshift with 1 Auxiliary Function (Internal Reeving)

### LOAD HANDLING (HOSE & VALVE ASSEMBLY) w/out SIDESHIFT

- 1 Auxiliary Function (Fixed Carriage only) (Internal Reeving)
- 2 Auxiliary Functions (Fixed Carriage only) (Internal Reeving)

### FORKS

- Various Fork Length Options
- Forks - Delete from Truck

### LIGHTS, INDICATORS & MISC.

- Various Travel Alarm Options
- Various Strobe Light Options
- LED Work Lights 2 Each (Mast Mounted)
- LED Rear Work Light
- LED Operator Compartment Light
- Blue Spot Light, Key-on, Both Directions
- Blue Spot Light, Key-on, Tractor First Only
- Electronic Horn
- Fire Extinguisher - 2.5 lb. Dry Chemical
- Technology Package Delete
- Weight Height Limit Display
- Electronic Key (Operator PIN Code Entry)
- Keyless On/Off Switch (in lieu of key switch)
- MyInsights® Telematics Display
- Name Plate (English, Spanish, English/French)
- Capacity Plate for Field Installed Attachments

### BODY

- Various Load Backrest Options
- Delete Load Backrest from Truck
- Various Overhead Guard Height Options
- OHG Plexiglass
- OHG Cover Mesh Cover
- Drive Unit Shrink Wrap Guards
- Standard Tread Frame for QFV (Narrow QFV)

### OPERABILITY AND COMFORT

- Factory Set Speed Control
- Operator Compartment Fan
- Extended Operator Compartment Backrest Delete
- Comfort Package Delete
- Variable Flow, Analog Control Handle
- Reverse Steering
- Programmable Lift Limit with Bypass (Specify Height)
- Programmable Lift Limit without Bypass (Specify Height)
- Lower Limit with Bypass
- Vertical Hold (Auto Height Select)
- Auto Fork Leveling (Both Directions)
- Heaters for Cold Storage
- Hinged Rear Operator Guard (full length)
- Operator Compartment Sensor System (CSS)
- Operator Compartment Sensor System (CSS)
- Export Preparation

### BATTERY ACCESSORIES

- Compact
- High-Capacity
- Battery Side Gate Interlock Switches (limits travel speed to 1 MPH)
- Various Battery Connectors
- Various Battery Spacer Options
- Toyota LIB ESS Tag
- CAN-COM and ESS Tag for Toyota LIB
- Toyota 5/35 Lithium-Ion Battery
- Toyota 8/50 Lithium-Ion Battery

### WHEELS AND TIRES

- Various Drive Tire Options
- Various Steer Tire Options

### SPECIAL MODELS

- Cold Storage Conditioning
- Special Paint Color - Single or Double (with black mast)
- UL-Approved Model Type E
- UL-Approved Model Type EE
- Asset Tag
- Non-Standard Spec

# TRUCK SPECIFICATIONS

MODEL NUMBERS

GENERAL DATA			8FBA15U			8FBA15U		
Load Capacity	lb (kg)		3000 (1361)			3000 (1361)		
Load Center	in (mm)		24 (600)			24 (600)		
Mast Type			FSW			QFV		
Battery Compartment Size	in	13.5	16.5	18.5	18.5	18.5	18.5 (Narrow Tread)	
Power Type			Battery			Battery		
Operator Position			Stand-Up			Stand-Up		

EXTERIOR DIMENSIONS			8FBA15U			8FBA15U		
			BATTERY COMPARTMENT SIZE			BATTERY COMPARTMENT SIZE		
			13.5"	16.5"	18.5"	18.5"	18.5" (Narrow Tread)	
<b>A</b> Maximum Fork Height (MFH)	in (mm)		227 (5766)			258.5 (6566)		
<b>B</b> Free Lift	in (mm)		51 (1295)	51 (1295)	59 (1499)	41 (1041)	35 (889)	
<b>C</b> Tilt Range (forward/backward)	degrees		3/5			3/5		
<b>D</b> Mast Lowered Height	in (mm)		99 (2515)	99 (2515)	107 (2718)	89 (2261)	83 (2108)	
<b>E</b> Mast Extended Height	in (mm)		275 (6985)	275 (6985)	299 (7594)	306.5 (7785)	289 (7341)	
<b>F</b> Battery Roller Height	in (mm)		7.5 (191)			7.5 (191)		
<b>G</b> Load Backrest Height	in (mm)		48 (1219)			48 (1219)		
<b>H</b> Overhead Guard Height <sup>2</sup>	in (mm)		88 (2235)			88 (2235)		
<b>I</b> Chassis Height <sup>4</sup>	in (mm)		50.5 (1283)			50.5 (1283)		
<b>J</b> Chassis Width <sup>3</sup>	in (mm)		41 (1041)			44 (1118)	41 (1041)	
<b>K</b> Wheelbase	in (mm)		45.6 (1158)	48.4 (1230)	50.4 (1280)	50.4 (1280)		
<b>L</b> Load Distance <sup>1</sup> (Centerline of front axle to front face of forks)	in (mm)		13.5 (343)			14.2 (361)	15.7 (399)	
<b>M</b> Length to Fork Face <sup>1</sup>	in (mm)		66.5 (1688)	69.2 (1758)	71.2 (1808)	71.8 (1823)	73.3 (1862)	
<b>N</b> Underclearance	in (mm)		4.1 (104)			4.1 (104)		
<b>O</b> Fork Size	L x T x W		42 x 1.5 x 4 (1067 x 38 x 102)			42 x 1.5 x 4 (1067 x 38 x 102)		
<b>P</b> Fork Spread (outer edge to edge)	Min-Max		13 - 33.45 (330 - 850)			10 - 35 (254 - 889)		
<b>Q</b> Turning Radius	in (mm)		53.1 (1349)	55.8 (1417)	57.8 (1468)	57.8 (1468)		
Basic Right Angle Stacking Aisle Width <sup>1</sup> (Add load length and clearance)	in (mm)		66.3 (1684)	69.1 (1755)	71.1 (1866)	71.8 (1823)	73.3 (1862)	
Carriage Width	in (mm)		36 (914)			36 (914)		
Step Height	in (mm)		9.4 (239)			9.4 (239)		
Operator Compartment	H X L X W		78.7 X 18.6 X 21.1 (1999 X 472 X 536)			78.7 X 18.6 X 21.1 (1999 X 472 X 536)		

PERFORMANCE DATA				8FBA15U			8FBA15U		
				BATTERY COMPARTMENT SIZE			BATTERY COMPARTMENT SIZE		
				13.5"	16.5"	18.5"	18.5"	18.5" (Narrow Tread)	
Speeds	Maximum Travel (fwd. / rev.)	Full Load	mph (km/h)	8.0 (12.87)			8.0 (12.87)		
		No Load	mph (km/h)	8.0 (12.87)			8.0 (12.87)		
	Lifting	Full Load	fpm (mm/sec)	100 (508)			100 (510)		
		No Load	fpm (mm/sec)	130 (660)			130 (660)		
	Lowering	Full Load	fpm (mm/sec)	113 (574)			97 (490)		
		No Load	fpm (mm/sec)	103 (523)			88 (450)		
Gradeability	Full Load	%	15			15			
Grade Clearance		%	38.7	36.3	34.6	34.6			

TRUCK WEIGHTS			8FBA15U			8FBA15U		
			BATTERY COMPARTMENT SIZE			BATTERY COMPARTMENT SIZE		
			13.5"	16.5"	18.5"	18.5"	18.5" (Narrow Tread)	
Total Weight	Without Battery	lb (kg)	7037 (3192)	6817 (3092)	7153 (3245)	7445 (3377)	7355 (3336)	

TIRES				8FBA15U			8FBA15U		
				BATTERY COMPARTMENT SIZE			BATTERY COMPARTMENT SIZE		
				13.5"	16.5"	18.5"	18.5"	18.5" (Narrow Tread)	
Tires	Tire Type	Front / Rear		Solid Rubber / Polyurethane			Solid Rubber / Polyurethane		
	Number (x = driven)	Front / Rear		2x / 2 (dual steer)			2x / 2 (dual steer)		
	Lifting	Front (Drive)	in (mm)	16.25 x 6 (413 x 152)			16.25 x 6 (413 x 152)		
Rear (Steer)		in (mm)	10 x 5 x 6.5 (254 x 127 x 165) (Dual)			10 x 5 x 6.5 (254 x 127 x 165) (Dual)			
Brake Pedal			Plugging / Electric Disc Brake			Plugging / Electric Disc Brake			

POWER SYSTEM				8FBA15U			8FBA15U		
				BATTERY COMPARTMENT SIZE			BATTERY COMPARTMENT SIZE		
				13.5"	16.5"	18.5"	13.5"	16.5"	
Battery Type				Lead Acid			Lead Acid		
Battery (6-hour ratings)	Compartment Size (W x L x H)	Maximum	in (mm)	38.5 x 13.75 x 32.3 (978 x 349 x 820)	38.5 x 16.5 x 32.3 (978 x 419 x 820)	38.5 x 18.5 x 32.3 (978 x 470 x 820)	38.5 x 18.5 x 32.3 (978 x 470 x 820)		
	Voltage / Capacity	Maximum	V/AH	36 / 800	36 / 930	36 / 1085	36 / 1085		
	Battery Size (W x L x H)	Maximum	in (mm)	38.5 x 13.5 x 32.3 (978 x 343 x 820)	38.5 x 16.3 x 32.3 (978 x 414 x 820)	38.5 x 18.3 x 32.3 (978 x 465 x 820)	38.5 x 18.3 x 32.3 (978 x 465 x 820)		
	Weight	Minimum	lb (kg)	1700 (771)	1980 (898)	2300 (1043)	2300 (1043)		
Motors	Drive		hp (kw)	4 Pole Induction AC 3-Phase 7.0 (5.2)			4 Pole Induction AC 3-Phase 7.0 (5.2)		
	Load Handling (Hydraulic)		hp (kw)	4 Pole Induction AC 3-Phase 18.6 (13.9)			4 Pole Induction AC 3-Phase 18.6 (13.9)		
		Electric Power Steering			4 Pole Induction AC 3-Phase			4 Pole Induction AC 3-Phase	
Control Type	Drive			Transistor - MOSFET			Transistor - MOSFET		
	Load Handling			Transistor - MOSFET			Transistor - MOSFET		
	Power Steering			Transistor - MOSFET			Transistor - MOSFET		
Operating Pressure	For Attachments	psi (kg / cm <sup>2</sup> )	2200			2200			
Auxiliary Flow Rate (3rd function)		gpm	2.5			2.5			
Auxiliary Flow Rate (4th function)		gpm	3 - 10			3 - 10			

1 Includes integral sideshift. Subtract 1.7 inches (43mm) for fixed carriage with no sideshift on FSW mast. Subtract 1.4 inches (36mm) for fixed carriage with no sideshift on QFV mast.  
 2 Overhead guard height - tolerance is 0.5 inch  
 3 Chassis width measured from outside to outside of drive tires (widest point on truck)

4 Chassis height with extended backrest is 60 inches (1524 mm)  
 5 Measured from lowest corner of the floor to underside of OHG canopy for standard 88 inch OHG  
 6 This vehicle is a 5000 lb. capacity tractor with a 4000 lb. capacity mast

GENERAL DATA			8FBA18U			8FBA18U		
Load Capacity	lb (kg)		3500 (1588)			3500 (1588)		
Load Center	in (mm)		24 (600)			24 (600)		
Mast Type			FSW			QFV		
Battery Compartment Size	in	13.5	16.5	18.5	18.5	18.5	18.5 (Narrow Tread)	
Power Type			Battery			Battery		
Operator Position			Stand-Up			Stand-Up		

EXTERIOR DIMENSIONS			8FBA18U BATTERY COMPARTMENT SIZE			8FBA18U BATTERY COMPARTMENT SIZE		
			13.5"	16.5"	18.5"	18.5"	18.5" (Narrow Tread)	
<b>A</b> Maximum Fork Height (MFH)	in (mm)		227 (5766)	227 (5766)	251 (6375)	258.5 (6566)	240.5 (6109)	
<b>B</b> Free Lift	in (mm)		51 (1295)	51 (1295)	59 (1499)	41 (1041)	35 (889)	
<b>C</b> Tilt Range (forward/backward)	degrees		3/5			3/5		
<b>D</b> Mast Lowered Height	in (mm)		99 (2515)	99 (2515)	107 (2718)	89 (2261)	83 (2108)	
<b>E</b> Mast Extended Height	in (mm)		275 (6985)	275 (6985)	299 (7594)	307 (7798)	289 (7341)	
<b>F</b> Battery Roller Height	in (mm)		7.5 (191)			7.5 (191)		
<b>G</b> Load Backrest Height	in (mm)		48 (1219)			48 (1219)		
<b>H</b> Overhead Guard Height <sup>2</sup>	in (mm)		88 (2235)			88 (2235)		
<b>I</b> Chassis Height <sup>4</sup>	in (mm)		50.5 (1283)			50.5 (1283)		
<b>J</b> Chassis Width <sup>3</sup>	in (mm)		41 (1041)			44 (1118)	41 (1041)	
<b>K</b> Wheelbase	in (mm)		45.6 (1158)	48.4 (1230)	50.4 (1280)	50.4 (1280)		
<b>L</b> Load Distance <sup>1</sup> (Centerline of front axle to front face of forks)	in (mm)		13.5 (343)			14.2 (361)		
<b>M</b> Length to Fork Face <sup>1</sup>	in (mm)		66.5 (1688)	69.2 (1758)	71.2 (1808)	71.8 (1823)	73.3 (1862)	
<b>N</b> Underclearance	in (mm)		4.1 (104)			4.1 (104)		
<b>O</b> Fork Size	L x T x W		42 x 1.5 x 4 (1067 x 38 x 102)			42 x 1.5 x 4 (1067 x 38 x 102)		
<b>P</b> Fork Spread (outer edge to edge)	Min-Max		13 - 33.45 (330 - 850)			10 - 35 (254 - 889)		
<b>Q</b> Turning Radius	in (mm)		53.1 (1349)	55.8 (1417)	57.8 (1468)	57.8 (1468)		
Basic Right Angle Stacking Aisle Width <sup>1</sup> (Add load length and clearance)	in (mm)		66.3 (1684)	69.1 (1755)	71.1 (1866)	71.8 (1823)		
Carriage Width	in (mm)		36 (914)			36 (914)		
Step Height	in (mm)		9.4 (239)			9.4 (239)		
Operator Compartment	H X L X W		78.7 X 18.6 X 21.1 (1999 X 472 X 536)			78.7 X 18.6 X 21.1 (1999 X 472 X 536)		

PERFORMANCE DATA				8FBA18U BATTERY COMPARTMENT SIZE			8FBA18U BATTERY COMPARTMENT SIZE		
				13.5"	16.5"	18.5"	18.5"	18.5" (Narrow Tread)	
Speeds	Maximum Travel (fwd. / rev.)	Full Load	mph (km/h)	8.0 (12.87)			8.0 (12.87)		
		No Load	mph (km/h)	8.0 (12.87)			8.0 (12.87)		
	Lifting	Full Load	fpm (mm/sec)	90 (457)			96 (488)		
		No Load	fpm (mm/sec)	132 (671)			130 (660)		
	Lowering	Full Load	fpm (mm/sec)	108 (549)			97 (490)		
		No Load	fpm (mm/sec)	98 (498)			88 (450)		
Gradeability	Full Load	%	15			15			
Grade Clearance		%	38.7	36.3	34.6	34.6			

TRUCK WEIGHTS			8FBA18U BATTERY COMPARTMENT SIZE			8FBA18U BATTERY COMPARTMENT SIZE		
			13.5"	16.5"	18.5"	18.5"	18.5" (Narrow Tread)	
Total Weight	Without Battery	lb (kg)	7422 (3367)	6817 (3092)	7153 (3245)	7445 (3377)	7355 (3336)	

TIRES				8FBA18U BATTERY COMPARTMENT SIZE			8FBA18U BATTERY COMPARTMENT SIZE		
				13.5"	16.5"	18.5"	18.5"	18.5" (Narrow Tread)	
Tires	Tire Type	Front / Rear		Solid Rubber / Polyurethane			Solid Rubber / Polyurethane		
	Number (x = driven)	Front / Rear		2x / 2 (dual steer)			2x / 2 (dual steer)		
	Lifting	Front (Drive)	in (mm)	16.25 x 6 (413 x 152)			16.25 x 6 (413 x 152)		
Rear (Steer)		in (mm)	10 x 5 x 6.5 (254 x 127 x 165) (Dual)			10 x 5 x 6.5 (254 x 127 x 165) (Dual)			
Brake Pedal			Plugging / Electric Disc Brake			Plugging / Electric Disc Brake			

POWER SYSTEM				8FBA18U BATTERY COMPARTMENT SIZE			8FBA18U BATTERY COMPARTMENT SIZE		
				13.5"	16.5"	18.5"	13.5"	16.5"	
Battery Type				Lead Acid			Lead Acid		
Battery (6-hour ratings)	Compartment Size (W x L x H)	Maximum	in (mm)	38.5 x 13.75 x 32.3 (978 x 349 x 820)	38.5 x 16.5 x 32.3 (978 x 419 x 820)	38.5 x 18.5 x 32.3 (978 x 470 x 820)	38.5 x 18.5 x 32.3 (978 x 470 x 820)		
	Voltage / Capacity	Maximum	V/AH	36 / 800	36 / 930	36 / 1085	36 / 1085		
	Battery Size (W x L x H)	Maximum	in (mm)	38.5 x 13.5 x 32.3 (978 x 343 x 820)	38.5 x 16.3 x 32.3 (978 x 414 x 820)	38.5 x 18.3 x 32.3 (978 x 465 x 820)	38.5 x 18.3 x 32.3 (978 x 465 x 820)		
	Weight	Minimum	lb (kg)	1700 (771)	1980 (898)	2300 (1043)	2300 (1043)		
Motors	Drive		hp (kw)	4 Pole Induction AC 3-Phase 7.0 (5.2)			4 Pole Induction AC 3-Phase 7.0 (5.2)		
	Load Handling (Hydraulic)		hp (kw)	4 Pole Induction AC 3-Phase 18.6 (13.9)			4 Pole Induction AC 3-Phase 18.6 (13.9)		
		Electric Power Steering			4 Pole Induction AC 3-Phase			4 Pole Induction AC 3-Phase	
Control Type	Drive			Transistor - MOSFET			Transistor - MOSFET		
	Load Handling			Transistor - MOSFET			Transistor - MOSFET		
	Power Steering			Transistor - MOSFET			Transistor - MOSFET		
Operating Pressure	For Attachments	psi (kg / cm <sup>2</sup> )	2200			2200			
Auxiliary Flow Rate (3rd function)		gpm	2.5			2.5			
Auxiliary Flow Rate (4th function)		gpm	3 - 10			3 - 10			

1 Includes integral sideshift. Subtract 1.7 inches (43mm) for fixed carriage with no sideshift on FSW mast. Subtract 1.4 inches (36mm) for fixed carriage with no sideshift on QFV mast.  
2 Overhead guard height - tolerance is 0.5 inch  
3 Chassis width measured from outside to outside of drive tires (widest point on truck)

4 Chassis height with extended backrest is 60 inches (1524 mm)  
5 Measured from lowest corner of the floor to underside of OHG canopy for standard 88 inch OHG  
6 This vehicle is a 5000 lb. capacity tractor with a 4000 lb. capacity mast

# TRUCK SPECIFICATIONS

				MODEL NUMBERS						
GENERAL DATA				8FBA20U		8FBA20U		8FBA20U		
Load Capacity	lb (kg)	4000 (1816)		4000 (1816)		4000 (1816)		4000 (1816)		
Load Center	in (mm)	24 (600)		24 (600)		24 (600)		24 (600)		
Mast Type		FSW		QFV		QFV		QFV		
Battery Compartment Size	in	18.5	21.25	18.5	18.5 (Narrow Tread)	21.25	21.25 (Narrow Tread)			
Power Type		Battery		Battery		Battery		Battery		
Operator Position		Stand-Up		Stand-Up		Stand-Up		Stand-Up		
EXTERIOR DIMENSIONS				8FBA20U		8FBA20U		8FBA20U		
				BATTERY COMPARTMENT SIZE		BATTERY COMPARTMENT SIZE		BATTERY COMPARTMENT SIZE		
				18.5"	21.25"	18.5"	18.5" (Narrow Tread)	21.25"	21.25" (Narrow Tread)	
<b>A</b>	Maximum Fork Height (MFH)	in (mm)	251 (6375)		258.5 (6566)		240.5 (6109)		258.5 (6566)	
<b>B</b>	Free Lift	in (mm)	59 (1499)		41 (1041)		35 (889)		41 (1041)	
<b>C</b>	Tilt Range (forward/backward)	degrees	3/5		3/5		3/5		3/5	
<b>D</b>	Mast Lowered Height	in (mm)	107 (2718)		89 (2261)		83 (2108)		89 (2261)	
<b>E</b>	Mast Extended Height	in (mm)	299 (7594)		306.5 (7785)		289 (7341)		307 (7798)	
<b>F</b>	Battery Roller Height	in (mm)	7.5 (191)		7.5 (191)		7.5 (191)		7.5 (191)	
<b>G</b>	Load Backrest Height	in (mm)	48 (1219)		48 (1219)		48 (1219)		48 (1219)	
<b>H</b>	Overhead Guard Height <sup>2</sup>	in (mm)	88 (2235)		88 (2235)		88 (2235)		88 (2235)	
<b>I</b>	Chassis Height <sup>4</sup>	in (mm)	50.5 (1283)		50.5 (1283)		50.5 (1283)		50.5 (1283)	
<b>J</b>	Chassis Width <sup>3</sup>	in (mm)	41 (1041)	42.5 (1080)	44 (1118)	41 (1041)	46 (1168)	42.5 (1080)		
<b>K</b>	Wheelbase	in (mm)	50.4 (1280)	53.1 (1349)	50.4 (1280)		53.1 (1349)			
<b>L</b>	Load Distance <sup>1</sup> (Centerline of front axle to front face of forks)	in (mm)	13.5 (343)		14.2 (361)		14.2 (361)			
<b>M</b>	Length to Fork Face <sup>1</sup>	in (mm)	71.2 (1808)	74.0 (1878)	71.8 (1823)	73.3 (1862)	74.5 (1893)	76.1 (1932)		
<b>N</b>	Underclearance	in (mm)	4.1 (104)		4.1 (104)		4.1 (104)			
<b>O</b>	Fork Size	L x T x W	42 x 1.5 x 4 (1067 x 38 x 102)		42 x 1.5 x 4 (1067 x 38 x 102)		42 x 1.5 x 4 (1067 x 38 x 102)			
<b>P</b>	Fork Spread (outer edge to edge)	Min-Max	13 - 33.45 (330 - 850)		13 - 33.45 (330 - 850)		13 - 33.45 (330 - 850)			
<b>Q</b>	Turning Radius	in (mm)	57.8 (1468)	60.5 (1537)	57.8 (1468)		60.5 (1537)			
	Basic Right Angle Stacking Aisle Width <sup>1</sup> (Add load length and clearance)	in (mm)	71.1 (1866)	73.8 (1875)	71.8 (1823)		74.5 (1893)			
	Carriage Width	in (mm)	36 (914)		36 (914)		36 (914)			
	Step Height	in (mm)	9.4 (239)		9.4 (239)		9.4 (239)			
	Operator Compartment	H X L X W	78.7 X 18.6 X 21.1 (1999 X 472 X 536)		78.7 X 18.6 X 21.1 (1999 X 472 X 536)		78.7 X 18.6 X 21.1 (1999 X 472 X 536)			
PERFORMANCE DATA				8FBA20U		8FBA20U		8FBA20U		
				BATTERY COMPARTMENT SIZE		BATTERY COMPARTMENT SIZE		BATTERY COMPARTMENT SIZE		
				18.5"	21.25"	18.5"	18.5" (Narrow Tread)	21.25"	21.25" (Narrow Tread)	
Speeds	Maximum Travel (fwd./ rev.)	Full Load	mph (km/h)	8.0 (12.87)		8.0 (12.87)		8.0 (12.87)		
		No Load	mph (km/h)	8.0 (12.87)		8.0 (12.87)		8.0 (12.87)		
	Lifting	Full Load	fpm (mm/sec)	92 (467)		92 (467)		92 (467)		
		No Load	fpm (mm/sec)	130 (660)		130 (660)		130 (660)		
	Lowering	Full Load	fpm (mm/sec)	113 (574)		97 (490)		88 (450)		
		No Load	fpm (mm/sec)	103 (523)		88 (450)		88 (450)		
Gradeability	Full Load	%	15		15		15			
Grade Clearance		%	38.7	36.3	34.6		32.7			
TRUCK WEIGHTS				8FBA20U		8FBA20U		8FBA20U		
				BATTERY COMPARTMENT SIZE		BATTERY COMPARTMENT SIZE		BATTERY COMPARTMENT SIZE		
				18.5"	21.25"	18.5"	18.5" (Narrow Tread)	21.25"	21.25" (Narrow Tread)	
Total Weight	Without Battery	lb (kg)	7037 (3192)	6817 (3092)	7445 (3377)	7355 (3336)	7545 (3422)			
TIRES				8FBA20U		8FBA20U		8FBA20U		
				BATTERY COMPARTMENT SIZE		BATTERY COMPARTMENT SIZE		BATTERY COMPARTMENT SIZE		
				18.5"	21.25"	18.5"	18.5" (Narrow Tread)	21.25"	21.25" (Narrow Tread)	
Tires	Tire Type	Front / Rear	Solid Rubber / Polyurethane		Solid Rubber / Polyurethane		Solid Rubber / Polyurethane			
	Number (x = driven)	Front / Rear	2x / 2 (dual steer)		2x / 2 (dual steer)		2x / 2 (dual steer)			
	Lifting	Front (Drive)	in (mm)	16.25 x 6 (413 x 152)	16.25 x 7 (413 x 178)	16.25 x 6 (413 x 152)		16.25 x 7 (413 x 178)		
Rear (Steer)		in (mm)	10 x 5 x 6.5 (254 x 127 x 165) (Dual)		10 x 5 x 6.5 (254 x 127 x 165) (Dual)		10 x 5 x 6.5 (254 x 127 x 165) (Dual)			
Brake Pedal			Plugging / Electric Disc Brake		Plugging / Electric Disc Brake		Plugging / Electric Disc Brake			
POWER SYSTEM				8FBA20U		8FBA20U		8FBA20U		
				BATTERY COMPARTMENT SIZE		BATTERY COMPARTMENT SIZE		BATTERY COMPARTMENT SIZE		
				18.5"	21.25"	18.5"	18.5" (Narrow Tread)	21.25"	21.25" (Narrow Tread)	
Battery Type			Lead Acid		Lead Acid		Lead Acid			
Battery (6-hour ratings)	Compartment Size (W x L x H)	Maximum	in (mm)	38.5 x 18.5 x 32.3 (978 x 470 x 820)	38.5 x 21.25 x 32.3 (978 x 540 x 820)	38.5 x 18.5 x 32.3 (978 x 470 x 820)	38.5 x 21.25 x 32.3 (978 x 540 x 820)			
	Voltage / Capacity	Maximum	V/AH	36 / 1085	36 / 1240	36 / 1085	36 / 1240			
	Battery Size (W x L x H)	Maximum	in (mm)	38.5 x 18.3 x 32.3 (978 x 465 x 820)	38.5 x 21.0 x 32.3 (978 x 533 x 820)	38.5 x 18.3 x 32.3 (978 x 465 x 820)	38.5 x 21.0 x 32.3 (978 x 533 x 820)			
	Weight	Minimum	lb (kg)	2300 (1043)	2593 (1176)	2300 (1043)		2593 (1176)		
Motors	Drive		4 Pole Induction AC 3-Phase		4 Pole Induction AC 3-Phase		4 Pole Induction AC 3-Phase			
		hp (kw)	7.0 (5.2)		7.0 (5.2)		7.0 (5.2)			
Load Handling (Hydraulic)			4 Pole Induction AC 3-Phase		4 Pole Induction AC 3-Phase		4 Pole Induction AC 3-Phase			
		hp (kw)	18.6 (13.9)		18.6 (13.9)		18.6 (13.9)			
Electric Power Steering			4 Pole Induction AC 3-Phase		4 Pole Induction AC 3-Phase		4 Pole Induction AC 3-Phase			
Control Type	Drive		Transistor - MOSFET		Transistor - MOSFET		Transistor - MOSFET			
	Load Handling		Transistor - MOSFET		Transistor - MOSFET		Transistor - MOSFET			
	Power Steering		Transistor - MOSFET		Transistor - MOSFET		Transistor - MOSFET			
Operating Pressure	For Attachments	psi (kg / cm <sup>2</sup> )	2200		2200		2200			
Auxiliary Flow Rate (3rd function)		gpm	2.5		2.5		2.5			
Auxiliary Flow Rate (4th function)		gpm	3 - 10		3 - 10		3 - 10			

1 Includes integral sideshift. Subtract 1.7 inches (43mm) for fixed carriage with no sideshift on FSW mast. Subtract 1.4 inches (36mm) for fixed carriage with no sideshift on QFV mast.  
 2 Overhead guard height - tolerance is 0.5 inch  
 3 Chassis width measured from outside to outside of drive tires (widest point on truck)

4 Chassis height with extended backrest is 60 inches (1524 mm)  
 5 Measured from lowest corner of the floor to underside of OHG canopy for standard 88 inch OHG  
 6 This vehicle is a 5000 lb. capacity tractor with a 4000 lb. capacity mast

GENERAL DATA		8FBA25U	8FBA25U
Load Capacity	lb (kg)	5000 (2268)	4000 (1814) <sup>6</sup>
Load Center	in (mm)	24 (600)	24 (600)
Mast Type		FSW	QFV
Battery Compartment Size	in	23.5	23.5 (Narrow Tread)
Power Type		Battery	Battery
Operator Position		Stand-Up	Stand-Up

EXTERIOR DIMENSIONS		8FBA25U BATTERY COMPARTMENT SIZE 23.5"	8FBA25U BATTERY COMPARTMENT SIZE 23.5" (Narrow Tread)
<b>A</b> Maximum Fork Height (MFH)	in (mm)	251 (6375)	270.5 (6871)
<b>B</b> Free Lift	in (mm)	59 (1499)	45 (1143)
<b>C</b> Tilt Range (forward/backward)	degrees	3/5	3/5
<b>D</b> Mast Lowered Height	in (mm)	107 (2718)	93.5 (2375)
<b>E</b> Mast Extended Height	in (mm)	299 (7594)	319 (8102)
<b>F</b> Battery Roller Height	in (mm)	7.5 (191)	7.5 (191)
<b>G</b> Load Backrest Height	in (mm)	48 (1219)	48 (1219)
<b>H</b> Overhead Guard Height <sup>2</sup>	in (mm)	88 (2235)	88 (2235)
<b>I</b> Chassis Height <sup>4</sup>	in (mm)	50.5 (1283)	50.5 (1283)
<b>J</b> Chassis Width <sup>3</sup>	in (mm)	42.5 (1080)	46 (1168) 42.5 (1080)
<b>K</b> Wheelbase	in (mm)	53.1 (1349)	53.1 (1349)
<b>L</b> Load Distance <sup>1</sup> (Centerline of front axle to front face of forks)	in (mm)	13.5 (343)	14.2 (361)
<b>M</b> Length to Fork Face <sup>1</sup>	in (mm)	76.7 (1948)	77.0 (1957) 78.6 (1995)
<b>N</b> Underclearance	in (mm)	4.1 (104)	4.1 (104)
<b>O</b> Fork Size	L x T x W	42 x 1.75 x 4 (1067 x 45 x 102)	42 x 1.5 x 4 (1067 x 38 x 102)
<b>P</b> Fork Spread (outer edge to edge)	Min-Max	13 - 33.45 (330 - 850)	13 - 33.45 (330 - 850)
<b>Q</b> Turning Radius	in (mm)	63 (1600)	63 (1600)
Basic Right Angle Stacking Aisle Width <sup>1</sup> (Add load length and clearance)	in (mm)	76.3 (1938)	77.0 (1957)
Carriage Width	in (mm)	36 (914)	36 (914)
Step Height	in (mm)	9.4 (239)	9.4 (239)
Operator Compartment	H X L X W	78.7 X 18.6 X 21.1 (1999 X 472 X 535)	78.7 X 18.6 X 21.1 (1999 X 472 X 535)

PERFORMANCE DATA				8FBA25U BATTERY COMPARTMENT SIZE 23.5"	8FBA25U BATTERY COMPARTMENT SIZE 23.5" (Narrow Tread)
Speeds	Maximum Travel (fwd. / rev.)	Full Load	mph (km/h)	8.0 (12.87)	8.0 (12.87)
		No Load	mph (km/h)	8.0 (12.87)	8.0 (12.87)
	Lifting	Full Load	fpm (mm/sec)	83 (421)	83 (421)
		No Load	fpm (mm/sec)	130 (660)	130 (660)
	Lowering	Full Load	fpm (mm/sec)	113 (574)	97 (490)
		No Load	fpm (mm/sec)	103 (523)	88 (450)
Gradeability	Full Load	%	15	15	
Grade Clearance		%	31.1	31.1	

TRUCK WEIGHTS			8FBA25U BATTERY COMPARTMENT SIZE 23.5"	8FBA25U BATTERY COMPARTMENT SIZE 23.5" (Narrow Tread)
Total Weight	Without Battery	lb (kg)	7393 (3353)	7753 (3517)

TIRES				8FBA25U BATTERY COMPARTMENT SIZE 23.5"	8FBA25U BATTERY COMPARTMENT SIZE 23.5" (Narrow Tread)
Tires	Tire Type	Front / Rear		Solid Rubber/Polyurethane	Solid Rubber/Polyurethane
	Number (x = driven)	Front / Rear		2x / 2 (dual steer)	2x / 2 (dual steer)
		Front (Drive)	in (mm)	16.25 x 7 (413 x 178)	16.25 x 7 (413 x 178)
	Lifting	Rear (Steer)	in (mm)	10 x 5 x 6.5 (254 x 127 x 165) (Dual)	10 x 5 x 6.5 (254 x 127 x 165) (Dual)
Brake Pedal			Plugging / Electric Disc Brake	Plugging / Electric Disc Brake	

POWER SYSTEM				8FBA25U BATTERY COMPARTMENT SIZE 23.5"	8FBA25U BATTERY COMPARTMENT SIZE 23.5"
Battery Type				Lead Acid	Lead Acid
Battery (6-hour ratings)	Compartment Size (W x L x H)	Maximum	in (mm)	38.5 x 23.75 x 32.3 (978 x 603 x 820)	38.5 x 23.75 x 32.3 (978 x 603 x 820)
		V/AH		36 / 1395	36 / 1395
	Battery Size (W x L x H)	Maximum	in (mm)	38.5 x 23.5 x 32.3 (978 x 597 x 820)	38.5 x 23.5 x 32.3 (978 x 597 x 820)
		Weight	Minimum	lb (kg)	2700 (1226)
Motors	Drive		hp (kw)	4 Pole Induction AC 3-Phase 7.1 (5.3)	4 Pole Induction AC 3-Phase 7.1 (5.3)
	Load Handling (Hydraulic)		hp (kw)	4 Pole Induction AC 3-Phase 18.6 (13.9)	4 Pole Induction AC 3-Phase 18.6 (13.9)
		Electric Power Steering			4 Pole Induction AC 3-Phase
Control Type	Drive			Transistor - MOSFET	Transistor - MOSFET
	Load Handling			Transistor - MOSFET	Transistor - MOSFET
	Power Steering			Transistor - MOSFET	Transistor - MOSFET
Operating Pressure	For Attachments	psi (kg / cm <sup>2</sup> )	2200	2200	
Auxiliary Flow Rate (3rd function)		gpm	2.5	2.5	
Auxiliary Flow Rate (4th function)		gpm	3 - 10	3 - 10	

1 Includes integral sideshift. Subtract 1.7 inches (43mm) for fixed carriage with no sideshift on FSW mast. Subtract 1.4 inches (36mm) for fixed carriage with no sideshift on QFV mast.  
2 Overhead guard height - tolerance is 0.5 inch  
3 Chassis width measured from outside to outside of drive tires (widest point on truck)

4 Chassis height with extended backrest is 60 inches (1524 mm)  
5 Measured from lowest corner of the floor to underside of OHG canopy for standard 88 inch OHG  
6 This vehicle is a 5000 lb. capacity tractor with a 4000 lb. capacity mast

EXTERIOR DIMENSIONS

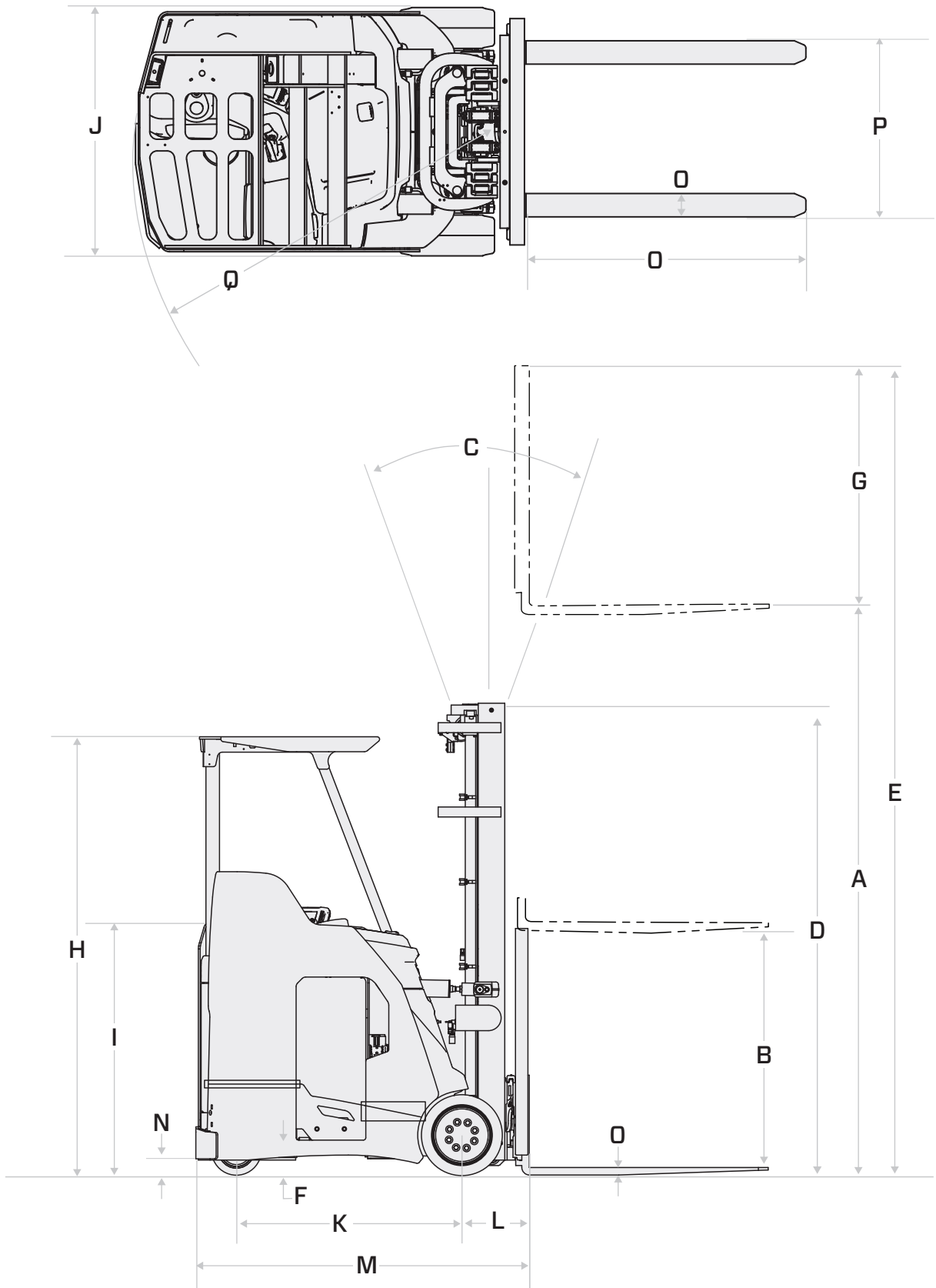

# MAST SPECIFICATIONS

MAST TYPE	MAXIMUM FORK HEIGHT (TOP OF FORKS)	OVERALL HEIGHT				FREE LIFT		TILT RANGE		FIXED CARRIAGE	4" INTEGRAL SS
		LOWERED	EXTENDED		WITHOUT LOAD BACKREST <sup>1</sup>	WITH STANDARD LOAD BACKREST	FWD	BWD			
			WITHOUT LOAD BACKREST <sup>1</sup>	WITH STANDARD LOAD BACKREST					in (mm)	in (mm)	deg
<b>8FBA15U - 13.5" BATTERY COMPARTMENT</b>											
8FBA15U FSW	188 (4775)	83 (2108)	208 (5283)	236 (5994)	63 (1600)	35 (889)	3	5	2600 (1179)	2600 (1179)	
	191 (4851)	84 (2133)	211 (5359)	239 (6070)	64 (1625)	36 (914)	3	5	2550 (1156)	2550 (1156)	
	203 (5156)	88 (2235)	223 (5664)	251 (6375)	68 (1727)	40 (1016)	3	5	2450 (1112)	2450 (1112)	
	224 (5690)	95 (2413)	244 (6198)	272 (6909)	75 (1905)	47 (1194)	3	5	2200 (998)	2200 (998)	
	227 (5766)	99 (2515)	247 (6274)	275 (6985)	79 (2006)	51 (1295)	3	5	2200 (998)	2200 (998)	

MAST TYPE	MAXIMUM FORK HEIGHT (TOP OF FORKS)	OVERALL HEIGHT				FREE LIFT		TILT RANGE		FIXED CARRIAGE	4" INTEGRAL SS
		LOWERED	EXTENDED		WITHOUT LOAD BACKREST <sup>1</sup>	WITH STANDARD LOAD BACKREST	FWD	BWD			
			WITHOUT LOAD BACKREST <sup>1</sup>	WITH STANDARD LOAD BACKREST					in (mm)	in (mm)	deg
<b>8FBA15U - 16.5" BATTERY COMPARTMENT</b>											
8FBA15U FSW	188 (4775)	83 (2108)	208 (5283)	236 (5994)	63 (1600)	35 (889)	3	5	2900 (1317)	2700 (1226)	
	191 (4851)	84 (2133)	211 (5359)	239 (6070)	64 (1625)	36 (914)	3	5	2850 (1293)	2650 (1202)	
	203 (5156)	88 (2235)	223 (5664)	251 (6375)	68 (1727)	40 (1016)	3	5	2800 (1271)	2600 (1179)	
	224 (5690)	95 (2413)	244 (6198)	272 (6909)	75 (1905)	47 (1194)	3	5	2450 (1112)	2450 (1112)	
	227 (5766)	99 (2515)	247 (6274)	275 (6985)	79 (2006)	51 (1295)	3	5	2600 (1180)	2450 (1112)	

MAST TYPE	MAXIMUM FORK HEIGHT (TOP OF FORKS)	OVERALL HEIGHT				FREE LIFT		TILT RANGE		FIXED CARRIAGE	4" INTEGRAL SS
		LOWERED	EXTENDED		WITHOUT LOAD BACKREST <sup>1</sup>	WITH STANDARD LOAD BACKREST	FWD	BWD			
			WITHOUT LOAD BACKREST <sup>1</sup>	WITH STANDARD LOAD BACKREST					in (mm)	in (mm)	deg
<b>8FBA15U - 18.5" BATTERY COMPARTMENT</b>											
8FBA15U FSW	188 (4775)	83 (2108)	208 (5283)	236 (5994)	63 (1600)	35 (889)	3	5	3000 (1361)	3000 (1361)	
	191 (4851)	84 (2133)	211 (5359)	239 (6070)	64 (1625)	36 (914)	3	5	3000 (1361)	3000 (1361)	
	203 (5156)	88 (2235)	223 (5664)	251 (6375)	68 (1727)	40 (1016)	3	5	3000 (1361)	3000 (1361)	
	224 (5690)	95 (2413)	244 (6198)	272 (6909)	75 (1905)	47 (1194)	3	5	3000 (1361)	3000 (1361)	
	227 (5766)	99 (2515)	247 (6274)	275 (6985)	79 (2006)	51 (1295)	3	5	3000 (1361)	3000 (1361)	
	251 (6375)	107 (2718)	271 (6883)	299 (7594)	87 (2210)	59 (1499)	3	5	2750 (1247)	2600 (1179)	

MAST TYPE	MAXIMUM FORK HEIGHT (TOP OF FORKS)	OVERALL HEIGHT				FREE LIFT		TILT RANGE		FIXED CARRIAGE	4" INTEGRAL SS
		LOWERED	EXTENDED		WITHOUT LOAD BACKREST <sup>1</sup>	WITH STANDARD LOAD BACKREST	FWD	BWD			
			WITHOUT LOAD BACKREST <sup>1</sup>	WITH STANDARD LOAD BACKREST					in (mm)	in (mm)	deg
<b>8FBA15U - 18.5" BATTERY COMPARTMENT WITH 2,300 LB. MINIMUM BATTERY WEIGHT</b>											
8FBA15U FSW	188 (4775)	83 (2108)	208 (5283)	236 (5994)	63 (1600)	35 (889)	3	5	3000 (1361)	3000 (1361)	
	191 (4851)	84 (2133)	211 (5359)	239 (6070)	64 (1625)	36 (914)	3	5	3000 (1361)	3000 (1361)	
	203 (5156)	88 (2235)	223 (5664)	251 (6375)	68 (1727)	40 (1016)	3	5	3000 (1361)	3000 (1361)	
	224 (5690)	95 (2413)	244 (6198)	272 (6909)	75 (1905)	47 (1194)	3	5	3000 (1361)	3000 (1361)	
	227 (5766)	99 (2515)	247 (6274)	275 (6985)	79 (2006)	51 (1295)	3	5	3000 (1361)	3000 (1361)	
	251 (6375)	107 (2718)	271 (6883)	299 (7594)	87 (2210)	59 (1499)	3	5	2950 (1338)	2700 (1225)	
8FBA15U QFV	240.5 (6109)	83 (2108)	266 (6756)	289 (7341)	63 (1600)	35 (889)	3	5	3000 (1361)	2700 (1225)	
	258.5 (6566)	89 (2261)	284 (7214)	307 (7798)	69 (1752)	41 (1041)	3	5	2500 (1134)	2350 (1066)	
8FBA15U QFV (Narrow Tread)	240.5 (6109)	83 (2108)	265 (6734)	289 (7341)	63 (1600)	35 (889)	3	5	2350 (1066)	2250 (1020)	

<sup>1</sup> This dimension is approximate. Dimension will need to be adjusted if any hoses or quick disconnects extend above the carriage.  
 NOTE: Height of standard load backrest is 48 in (1219 mm).  
 Full-Free Lift Three-Stage Mast (FSW), Full-Free Lift Four-Stage Mast (QFV)

## MAST SPECIFICATIONS

MAST TYPE	MAXIMUM FORK HEIGHT (TOP OF FORKS)	OVERALL HEIGHT				FREE LIFT		TILT RANGE		FIXED CARRIAGE	4" INTEGRAL SS
		LOWERED	EXTENDED		WITHOUT LOAD BACKREST <sup>1</sup>	WITH STANDARD LOAD BACKREST	FWD	BWD	LOAD CAPACITY AT 24 IN (600 MM) LC	LOAD CAPACITY AT 24 IN (600 MM) LC	
			WITHOUT LOAD BACKREST <sup>1</sup>	WITH STANDARD LOAD BACKREST							
in (mm)	in (mm)	in (mm)	in (mm)	in (mm)	in (mm)	deg	deg	lb (kg)	lb (kg)		
<b>8FBA18U - 13.5" BATTERY COMPARTMENT</b>											
8FBA18U FSW	188 (4775)	83 (2108)	83 (2108)	208 (5283)	236 (5994)	35 (889)	3	5	2900 (1317)	2900 (1317)	
	191 (4851)	84 (2133)	84 (2133)	211 (5359)	239 (6070)	36 (914)	3	5	2850 (1293)	2850 (1293)	
	203 (5156)	88 (2235)	88 (2235)	223 (5664)	251 (6375)	40 (1016)	3	5	2750 (1247)	2750 (1247)	
	224 (5690)	95 (2413)	95 (2413)	244 (6198)	272 (6909)	47 (1194)	3	5	2500 (1134)	2500 (1134)	
	227 (5766)	99 (2515)	99 (2515)	247 (6274)	275 (6985)	51 (1295)	3	5	2500 (1134)	2500 (1134)	

MAST TYPE	MAXIMUM FORK HEIGHT (TOP OF FORKS)	OVERALL HEIGHT				FREE LIFT		TILT RANGE		FIXED CARRIAGE	4" INTEGRAL SS
		LOWERED	EXTENDED		WITHOUT LOAD BACKREST <sup>1</sup>	WITH STANDARD LOAD BACKREST	FWD	BWD	LOAD CAPACITY AT 24 IN (600 MM) LC	LOAD CAPACITY AT 24 IN (600 MM) LC	
			WITHOUT LOAD BACKREST <sup>1</sup>	WITH STANDARD LOAD BACKREST							
in (mm)	in (mm)	in (mm)	in (mm)	in (mm)	in (mm)	deg	deg	lb (kg)	lb (kg)		
<b>8FBA18U - 16.5" BATTERY COMPARTMENT</b>											
8FBA18U FSW	188 (4775)	83 (2108)	83 (2108)	208 (5283)	236 (5994)	35 (889)	3	5	3300 (1497)	3075 (1396)	
	191 (4851)	84 (2133)	84 (2133)	211 (5359)	239 (6070)	36 (914)	3	5	3250 (1474)	3050 (1383)	
	203 (5156)	88 (2235)	88 (2235)	223 (5664)	251 (6375)	40 (1016)	3	5	3200 (1451)	2950 (1339)	
	224 (5690)	95 (2413)	95 (2413)	244 (6198)	272 (6909)	47 (1194)	3	5	2700 (1226)	2700 (1226)	
	227 (5766)	99 (2515)	99 (2515)	247 (6274)	275 (6985)	51 (1295)	3	5	2700 (1226)	2700 (1226)	

MAST TYPE	MAXIMUM FORK HEIGHT (TOP OF FORKS)	OVERALL HEIGHT				FREE LIFT		TILT RANGE		FIXED CARRIAGE	4" INTEGRAL SS
		LOWERED	EXTENDED		WITHOUT LOAD BACKREST <sup>1</sup>	WITH STANDARD LOAD BACKREST	FWD	BWD	LOAD CAPACITY AT 24 IN (600 MM) LC	LOAD CAPACITY AT 24 IN (600 MM) LC	
			WITHOUT LOAD BACKREST <sup>1</sup>	WITH STANDARD LOAD BACKREST							
in (mm)	in (mm)	in (mm)	in (mm)	in (mm)	in (mm)	deg	deg	lb (kg)	lb (kg)		
<b>8FBA18U - 18.5" BATTERY COMPARTMENT WITH 2,000 LB. MINIMUM BATTERY WEIGHT</b>											
8FBA18U FSW	188 (4775)	83 (2108)	208 (5283)	236 (5994)	63 (1600)	35 (889)	3	5	3500 (1588)	3500 (1588)	
	191 (4851)	84 (2133)	211 (5359)	239 (6070)	64 (1625)	36 (914)	3	5	3500 (1588)	3450 (1565)	
	203 (5156)	88 (2235)	223 (5664)	251 (6375)	68 (1727)	40 (1016)	3	5	3500 (1588)	3300 (1497)	
	224 (5690)	95 (2413)	244 (6198)	272 (6909)	75 (1905)	47 (1194)	3	5	3350 (1520)	3050 (1384)	
	227 (5766)	99 (2515)	247 (6274)	275 (6985)	79 (2006)	51 (1295)	3	5	3350 (1520)	3050 (1384)	
	251 (6375)	107 (2718)	271 (6883)	299 (7594)	87 (2210)	59 (1499)	3	5	2750 (1247)	2600 (1179)	

MAST TYPE	MAXIMUM FORK HEIGHT (TOP OF FORKS)	OVERALL HEIGHT				FREE LIFT		TILT RANGE		FIXED CARRIAGE	4" INTEGRAL SS
		LOWERED	EXTENDED		WITHOUT LOAD BACKREST <sup>1</sup>	WITH STANDARD LOAD BACKREST	FWD	BWD	LOAD CAPACITY AT 24 IN (600 MM) LC	LOAD CAPACITY AT 24 IN (600 MM) LC	
			WITHOUT LOAD BACKREST <sup>1</sup>	WITH STANDARD LOAD BACKREST							
in (mm)	in (mm)	in (mm)	in (mm)	in (mm)	in (mm)	deg	deg	lb (kg)	lb (kg)		
<b>8FBA18U - 18.5" BATTERY COMPARTMENT WITH 2,300 LB. MINIMUM BATTERY WEIGHT</b>											
8FBA18U FSW	188 (4775)	83 (2108)	208 (5283)	236 (5994)	63 (1600)	35 (889)	3	5	3500 (1588)	3500 (1588)	
	191 (4851)	84 (2133)	211 (5359)	239 (6070)	64 (1625)	36 (914)	3	5	3500 (1588)	3500 (1588)	
	203 (5156)	88 (2235)	223 (5664)	251 (6375)	68 (1727)	40 (1016)	3	5	3500 (1588)	3350 (1523)	
	224 (5690)	95 (2413)	244 (6198)	272 (6909)	75 (1905)	47 (1194)	3	5	3400 (1542)	3050 (1383)	
	227 (5766)	99 (2515)	247 (6274)	275 (6985)	79 (2006)	51 (1295)	3	5	3400 (1542)	3050 (1383)	
	251 (6375)	107 (2718)	271 (6883)	299 (7594)	87 (2210)	59 (1499)	3	5	2950 (1338)	2700 (1225)	
8FBA18U QFV	240.5 (6109)	83 (2108)	265 (6734)	289 (7341)	63 (1600)	35 (889)	3	5	3300 (1497)	2975 (1349)	
	258.5 (6566)	89 (2261)	283 (7191)	307 (7798)	69 (1752)	41 (1041)	3	5	2500 (1134)	2350 (1066)	
8FBA18U QFV (Narrow Tread)	240.5 (6109)	83 (2108)	265 (6734)	289 (7341)	63 (1600)	35 (889)	3	5	2350 (1066)	2250 (1020)	

<sup>1</sup> This dimension is approximate. Dimension will need to be adjusted if any hoses or quick disconnects extend above the carriage.  
NOTE: Height of standard load backrest is 48 in (1219 mm).  
Full-Free Lift Three-Stage Mast (FSW), Full-Free Lift Four-Stage Mast (QFV)

MAST TYPE	MAXIMUM FORK HEIGHT (TOP OF FORKS)	OVERALL HEIGHT			FREE LIFT		TILT RANGE		FIXED CARRIAGE	4" INTEGRAL SS
		LOWERED	EXTENDED		WITHOUT LOAD BACKREST <sup>1</sup>	WITH STANDARD LOAD BACKREST	FWD	BWD		
			in (mm)	WITHOUT LOAD BACKREST <sup>1</sup>					WITH STANDARD LOAD BACKREST	in (mm)

**8FBA20U - 18.5" BATTERY COMPARTMENT WITH 2,300 LB. MINIMUM BATTERY WEIGHT**

8FBA20U FSW	188 (4775)	83 (2108)	208 (5283)	236 (5994)	63 (1600)	35 (889)	3	5	3500 (1588)	3500 (1588)
	191 (4851)	84 (2133)	211 (5359)	239 (6070)	64 (1625)	36 (914)	3	5	3500 (1588)	3500 (1588)
	203 (5156)	88 (2235)	223 (5664)	251 (6375)	68 (1727)	40 (1016)	3	5	3500 (1588)	3350 (1523)
	224 (5690)	95 (2413)	244 (6198)	272 (6909)	75 (1905)	47 (1194)	3	5	3400 (1542)	3050 (1384)
	227 (5766)	99 (2515)	247 (6274)	275 (6985)	79 (2006)	51 (1295)	3	5	3400 (1542)	3050 (1384)
8FBA20U QFV	240.5 (6109)	83 (2108)	265 (6734)	289 (7341)	63 (1600)	35 (889)	3	5	3300 (1497)	2975 (1349)
	258.5 (6566)	89 (2261)	283 (7191)	307 (7798)	69 (1752)	41 (1041)	3	5	2500 (1134)	2350 (1066)
8FBA20U QFV (Narrow Tread)	240.5 (6109)	83 (2108)	265 (6734)	289 (7341)	63 (1600)	35 (889)	3	5	2350 (1066)	2250 (1020)

MAST TYPE	MAXIMUM FORK HEIGHT (TOP OF FORKS)	OVERALL HEIGHT			FREE LIFT		TILT RANGE		FIXED CARRIAGE	4" INTEGRAL SS
		LOWERED	EXTENDED		WITHOUT LOAD BACKREST <sup>1</sup>	WITH STANDARD LOAD BACKREST	FWD	BWD		
			in (mm)	WITHOUT LOAD BACKREST <sup>1</sup>					WITH STANDARD LOAD BACKREST	in (mm)

**8FBA20U - 21.25" BATTERY COMPARTMENT WITH 2,593 LB. MINIMUM BATTERY WEIGHT**

8FBA20U FSW	188 (4775)	83 (2108)	208 (5283)	236 (5994)	63 (1600)	35 (889)	3	5	4000 (1814)	4000 (1814)
	191 (4851)	84 (2133)	211 (5359)	239 (6070)	64 (1625)	36 (914)	3	5	4000 (1814)	4000 (1814)
	203 (5156)	88 (2235)	223 (5664)	251 (6375)	68 (1727)	40 (1016)	3	5	4000 (1814)	4000 (1814)
	224 (5690)	95 (2413)	244 (6198)	272 (6909)	75 (1905)	47 (1194)	3	5	3800 (1724)	3450 (1565)
	227 (5766)	99 (2515)	247 (6274)	275 (6985)	79 (2006)	51 (1295)	3	5	3800 (1724)	3450 (1565)
8FBA20U QFV	240.5 (6109)	83 (2108)	265 (6734)	289 (7341)	63 (1600)	35 (889)	3	5	3300 (1497)	2975 (1349)
	258.5 (6566)	89 (2261)	283 (7191)	307 (7798)	69 (1752)	41 (1041)	3	5	3110 (1411)	2800 (1270)
8FBA20U QFV (Narrow Tread)	240.5 (6109)	83 (2108)	265 (6734)	289 (7341)	63 (1600)	35 (889)	3	5	2500 (1134)	2400 (1089)
	258.5 (6566)	89 (2261)	283 (7191)	307 (7798)	69 (1752)	41 (1041)	3	5	2500 (1134)	2400 (1089)

MAST TYPE	MAXIMUM FORK HEIGHT (TOP OF FORKS)	OVERALL HEIGHT			FREE LIFT		TILT RANGE		FIXED CARRIAGE	4" INTEGRAL SS
		LOWERED	EXTENDED		WITHOUT LOAD BACKREST <sup>1</sup>	WITH STANDARD LOAD BACKREST	FWD	BWD		
			in (mm)	WITHOUT LOAD BACKREST <sup>1</sup>					WITH STANDARD LOAD BACKREST	in (mm)

**8FBA25U - 23.5" BATTERY COMPARTMENT WITH 2,593 LB. MINIMUM BATTERY WEIGHT**

8FBA25U FSW	188 (4775)	83 (2108)	208 (5283)	236 (5994)	63 (1600)	35 (889)	3	5	5000 (2268)	4700 (2131)
	191 (4851)	84 (2133)	211 (5359)	239 (6070)	64 (1625)	36 (914)	3	5	4900 (2222)	4600 (2086)
	203 (5156)	88 (2235)	223 (5664)	251 (6375)	68 (1727)	40 (1016)	3	5	4600 (2086)	4500 (2041)
	224 (5690)	95 (2413)	244 (6198)	272 (6909)	75 (1905)	47 (1194)	3	5	4100 (1860)	4000 (1814)
	227 (5766)	99 (2515)	247 (6274)	275 (6985)	79 (2006)	51 (1295)	3	5	4100 (1860)	4000 (1814)
8FBA25U QFV	240.5 (6109)	83 (2108)	265 (6734)	289 (7341)	63 (1600)	35 (889)	3	5	3300 (1497)	2975 (1349)
	258.5 (6566)	89 (2261)	283 (7191)	307 (7798)	69 (1752)	41 (1041)	3	5	3110 (1411)	2800 (1270)
	270.5 (6871)	93.5 (2375)	291 (7391)	319 (8102)	73 (1854)	45 (1143)	3	5	2800 (1270)	2600 (1179)
8FBA25U QFV (Narrow Tread)	240.5 (6109)	83 (2108)	265 (6734)	289 (7341)	63 (1600)	35 (889)	3	5	2850 (1293)	2750 (1247)
	258.5 (6566)	89 (2261)	283 (7191)	307 (7798)	69 (1752)	41 (1041)	3	5	2800 (1270)	2700 (1225)
	270.5 (6871)	93.5 (2375)	291 (7391)	319 (8102)	73 (1854)	45 (1143)	3	5	2700 (1225)	2600 (1179)

<sup>1</sup> This dimension is approximate. Dimension will need to be adjusted if any hoses or quick disconnects extend above the carriage.  
NOTE: Height of standard load backrest is 48 in (1219 mm).  
Full-Free Lift Three-Stage Mast (FSW), Full-Free Lift Four-Stage Mast (QFV)



# “I’M HERE TO MAKE SURE YOUR FORKLIFTS DON’T TAKE VACATION DAYS.”

Butch – 360 Technician, ProLift, Cincinnati, Ohio



## HELP IS ALWAYS HERE WITH TOYOTA 360 SUPPORT.

The industry’s best and most comprehensive dealer network quickly delivers Toyota Certified Technicians to your work site. These specially trained technicians can also help assess your warehouse and facility needs to recommend the right equipment for the job. And with the largest fleet of material handling equipment, Toyota 360 keeps your business running at full speed.

[ToyotaForklift.com/360-Support](http://ToyotaForklift.com/360-Support)



**YOUR BUSINESS IS RIDING ON IT.**

Some product features described herein are optional. Please consult your dealer for specifications. Details of specifications and equipment are based on information available at time of printing and may change without notice. Photos may not reflect physical trucks.

