



STANDARD SPECIFICATIONS

Performance

Platform Height	20-ft-4-in / 6.20-m
Horizontal Outreach	6-ft 5-in / 1.97-m
Up and Over Height	16-ft 8-in / 5.08-m
Swing	345 Degrees Non-continuous
Platform Capacity	500-lb / 227-kg
Platform Size	32 x 36-in / 85 x 92-cm
Weight*	4,980-lb / 2,260-kg
Ground Bearing Pressure	255 psi / 17.9 kg/cm ²
Ground Clearance	3.9-in / 10-cm
Drive Speed (Stowed)	3.4 mph / 5.5 km/h
Drive Speed (Elevated)	0.47 mph / 0.76 km/h
Gradeability	25%
Turning Radius (Inside)	1-ft-10-in / 56-cm
Turning Radius (Outside)	6-ft-6-in / 1.98-m

*Certain options or country standards increase weight

Power Source

Batteries	24V-DC, 4 x 6V 213 ah AGM
Charger	27 amps

Brakes

Spring Applied Disc

Tires

16-in x 5-in Non-Marking

KEY SPECS

Platform Height
20-ft-4-in / 6.20-m

Horizontal Outreach
6-ft 5-in / 1.97-m

Up and Over Height
16-ft-8-in / 5.08-m

Platform Capacity
500-lb / 227-kg

KEY FEATURES

- Reach up and over obstacles in tight spaces with a vertical telescopic mast with a jib.
- Equipped for indoor jobs with standard non-marking tires and efficient electric power, and for outdoor work with 25% gradeability.
- Unmatched positioning capabilities with a 345 degree rotating mast.
- Optimum battery life and more duty cycles with AC direct electric drive.

STANDARD FEATURES

- 110V-AC Receptacle in the Platform
- 345 Degree Non-continuous Swing
- 5 Degree Tilt Alarm/Indicator Light
- All Motion Alarm
- Battery Condition Indicator
- ClearSky Smart Fleet™ Hardware (CS550)
- Emergency Lowering Pump
- Horn
- Hourmeter
- LED Motion/Amber Beacon (CS550)
- Lifting Eyes
- Load Sensing System
- Proportional Controls
- Platform, Saloon Gate
- SkyGuard SkyLine™
- Tie-down Lugs
- Warning Beacon

ACCESSORIES & OPTIONS

- 5/16-in Airline
- 70W Platform Work Light
- Console Cover
- Platform, Drop Bar

DIMENSIONS

All dimensions are approximate

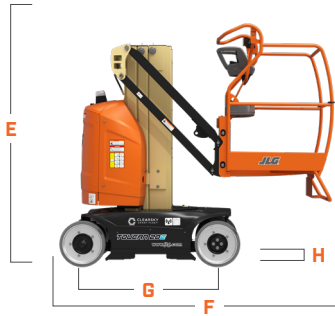
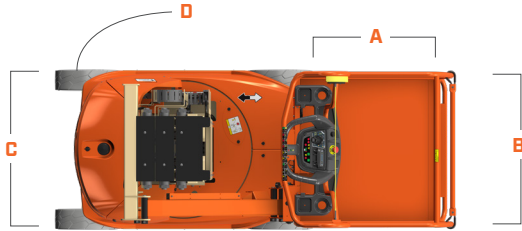

- A.** Platform Width 32-in / 0.81-m
- B.** Platform Length 36-in / 0.90-m
- C.** Machine Width 3-ft 3-in / 0.99-m
- D.** Tailswing 6.7-in / 17-cm
- E.** Machine Height 6-ft-6-in / 1.99-m
- F.** Machine Length 6-ft-11-in / 2.10-m
- G.** Wheelbase 3-ft-11-in / 1.2-m
- H.** Ground Clearance 3.9-in / 10-cm

REACH DIAGRAM

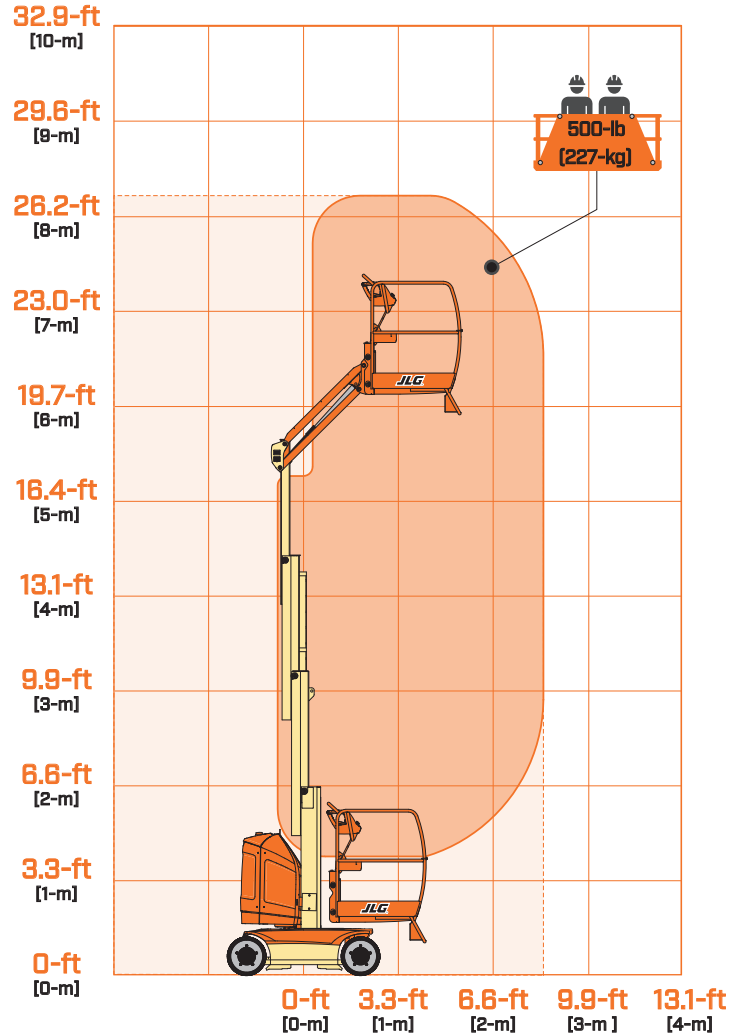

We provide coverage for one (1) full year, and cover all specified major structural components for five (5) years. Due to continuous product improvements, we reserve the right to make specification and/or equipment changes without prior notification. This machine meets or exceeds applicable ANSI and CSA requirements based on machine configuration as originally manufactured for intended applications. Please reference the serial number plate on the machine for additional information.



JLG INDUSTRIES, INC.
Toll-free US 877-JLG-LIFT
JLG.com

An Oshkosh Corporation Business