

X540AJ

COMPACT CRAWLER

BOOM LIFT



KEY SPECS

Platform Height

54-ft / 16.46-m

Platform Capacity

500-lb / 227-kg

Horizontal Outreach

24-ft / 7.32-m

Overall Width

31-in / 0.78-m

KEY FEATURES

- Features a 500-lb unrestricted platform capacity with SkyGuard SkyLine™ standard.
- Environmentally friendly with standard AC powered boom functions with diesel, optional bi-energy or optional lithium-ion electrical system for emission-free operation.
- Access tight spaces and climb slopes with ease thanks to a narrow chassis and tracked wheel carriage.
- Transport with ease by a forklift or crane with forklift pockets and lifting points, and fits through standard doorway.

ACCESSORIES & OPTIONS

- Black Deep-Tread Tracks
- Bi-Energy Power Option - Includes Diesel Engine and Lithium-Ion Battery
- Radio Remote Control

STANDARD SPECIFICATIONS

Performance

| | |
|--------------------------------------|----------------------------------|
| Platform Height | 54-ft / 16.46-m |
| Horizontal Outreach | 24-ft / 7.32-m |
| Platform Capacity | 500-lb / 227-kg |
| Swing | 360 Degrees Non-continuous |
| Platform Rotation | 124 Degrees (+62, -62 Degrees) |
| Jib (Range of Articulation) | 89 Degrees (0, -89 Degrees) |
| Ground Bearing Pressure (Tracks) | 8.8 psi / .62 kg/cm ² |
| Ground Bearing Pressure (Outriggers) | 36 psi / 2.53 kg/cm ² |
| Drive Speed | 1.6 mph / 2.5 km/h |
| Max Approach / Depart Angles | 18° / 19° |
| Max Stabilization Slope | 12 Degrees |
| Gradeability | 28% |
| Weight* (Diesel) | 6,239-lbs / 2,830-kg |
| Weight* (Lithium) | 6,349-lbs / 2,880-kg |
| Weight* (Bi-Energy) | 6,592-lbs / 2,990-kg |

*Certain options or country standards increase weight

Power

| | |
|-------------------------------|-------------------------------------|
| Engine: Kubota Diesel | 14.5 hp |
| Fuel Tank Capacity | 4 gal / 15.5 L |
| AC Motor | 120V AC / 60 HZ |
| Optional: Lithium Ion Battery | 64 V / 120 Ah |
| Optional: Bi-Energy | Kubota Diesel + Lithium Ion Battery |

Tracks

| | |
|----------|--------------------|
| Standard | Non-marking Tracks |
|----------|--------------------|

Hydraulic System

| | |
|----------|------------------|
| Capacity | 10.56 gal / 40 L |
|----------|------------------|

STANDARD FEATURES

- 110V-AC receptacle at Platform
- Air/Water Line to Platform
- Caster Platform Wheels
- Color Remote and Ground Panel Provides On-board Diagnostics
- Control Box with New Color Display
- Electric Controls With One-Touch Outrigger Deployment, Stowage & Leveling
- Flashing Amber Beacon
- Fork Pockets and Lifting Points
- Large Teflon® Outrigger Pads
- Load Sensing System
- Non-Marking Tracks
- On Board Battery Heaters
- Patented Quick Disconnect Two-Person Platform with Dual Side Entry
- Powered Track Widening
- SkyGuard SkyLine™
- Synthetic Biodegradable Hydraulic Oil

X540AJ

COMPACT CRAWLER

BOOM LIFT



DIMENSIONS

All dimensions are approximate

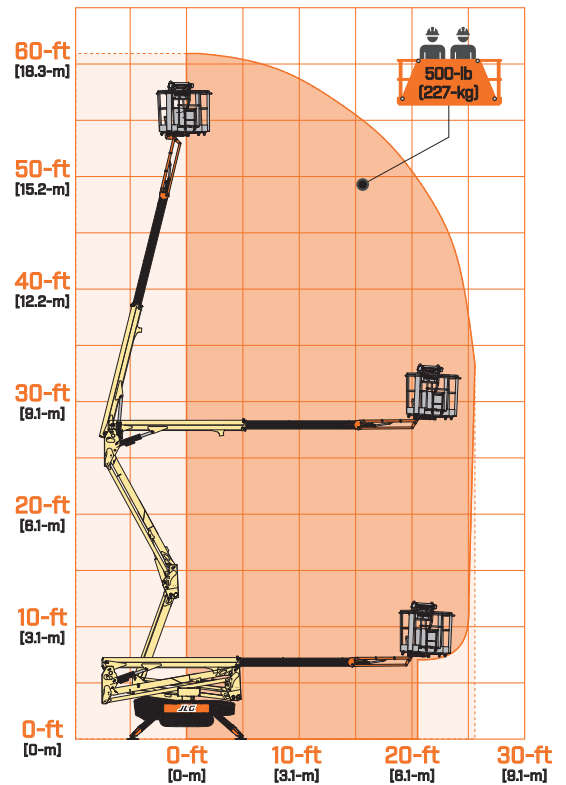
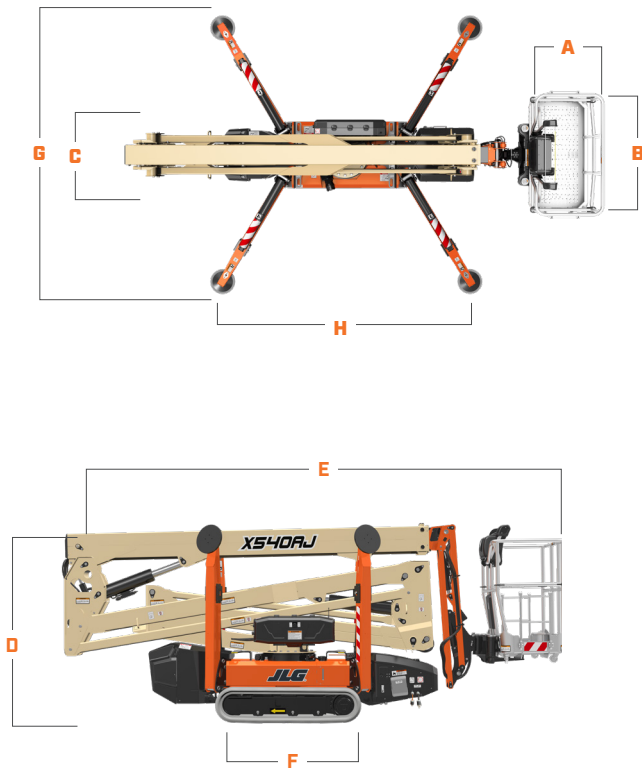

| | |
|---|--------------------|
| A. Platform Width | 30.4-in / .77-m |
| B. Platform Length | 55-in / 1.4-m |
| C. Machine Width with Platform | 55-in / 1.4-m |
| Machine Width without Platform Tracks Retracted | 31.3-in / .8-m |
| Machine Width without Platform Tracks Extended | 43.1-in / 1.1-m |
| D. Machine Height | 6-ft 7-in / 1.99-m |
| E. Machine Length | 16-ft 7-in / 5.1-m |
| Machine Length Without Platform | 14-ft 6-in / 4.4-m |
| F. Track length | 4-ft 10-in / 1.5-m |
| G. Outrigger Footprint Length | 9-ft 7-in / 2.9-m |
| H. Outrigger Footprint Width | 9-ft 7-in / 2.9-m |
| Outrigger Pad Diameter | 11.8-in / 30-cm |

Images for reference only



We provide coverage for one (1) full year, and cover all specified major structural components for five (5) years. Due to continuous product improvements, we reserve the right to make specification and/or equipment changes without prior notification. This machine meets or exceeds applicable ANSI and CSA requirements based on machine configuration as originally manufactured for intended applications. Please reference the serial number plate on the machine for additional information.



JLG INDUSTRIES, INC.
Toll-free US 877-JLG-LIFT
JLG.com

An Oshkosh Corporation Business