

Genie®

FULL FAMILY BROCHURE

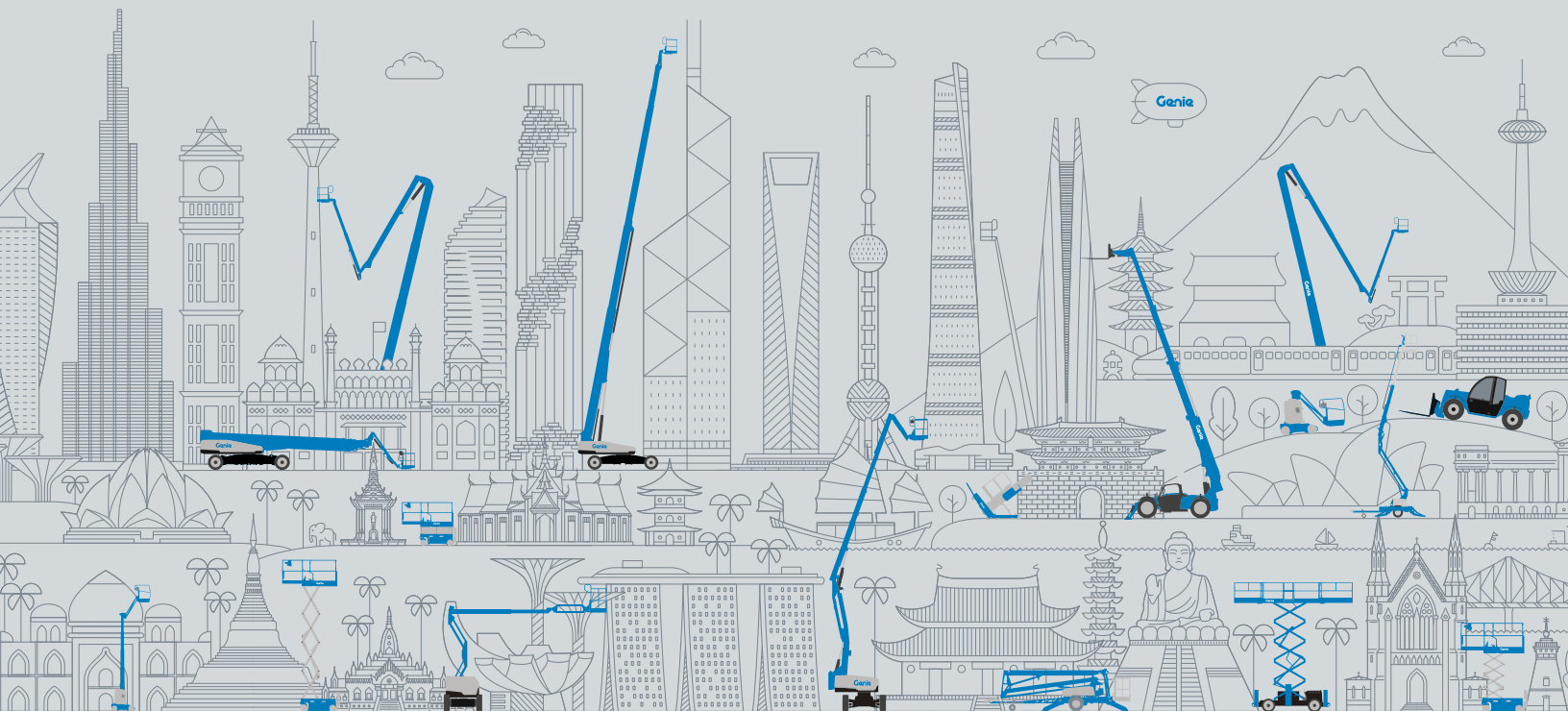

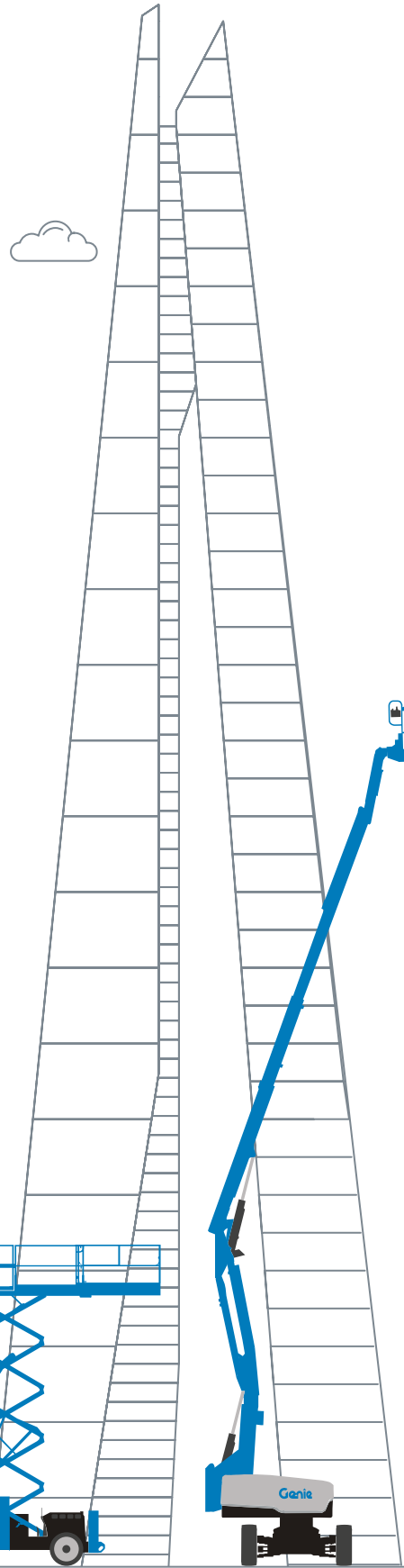
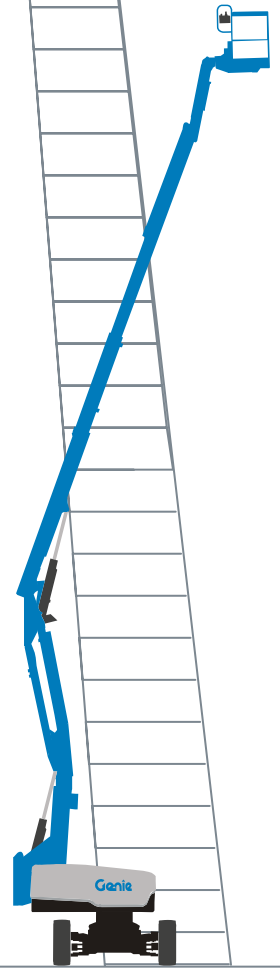
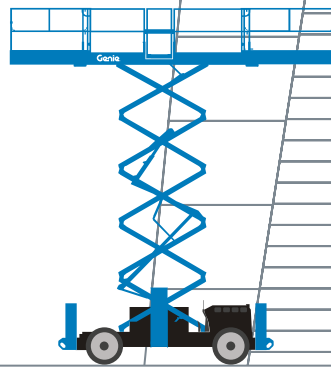
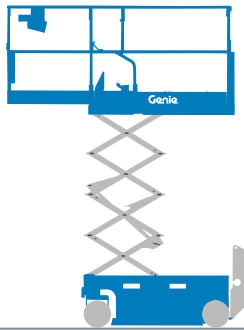
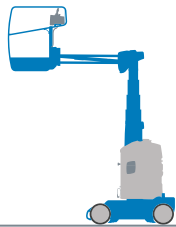
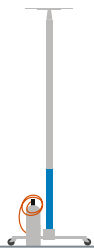
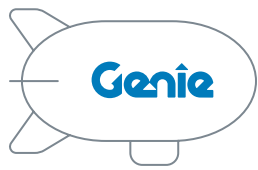

GENIE® PRODUCT RANGE

OUR STORY – QUALITY BY DESIGN

GENIE MATERIAL LIFTS

GENIE AERIAL WORK PLATFORMS

GENIE VERTICAL MAST LIFTS

GENIE GS™ SLAB SCISSOR LIFTS

GENIE GS ROUGH TERRAIN SCISSOR LIFTS

GENIE ARTICULATING Z® BOOM LIFTS

GENIE TELESCOPIC S® BOOM LIFTS

GENIE TRAILER-MOUNTED TZ™ BOOM LIFTS

GENIE GTH™ TELEHANDLERS

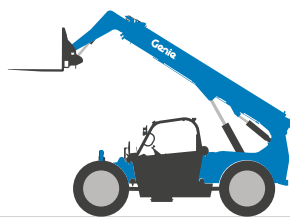
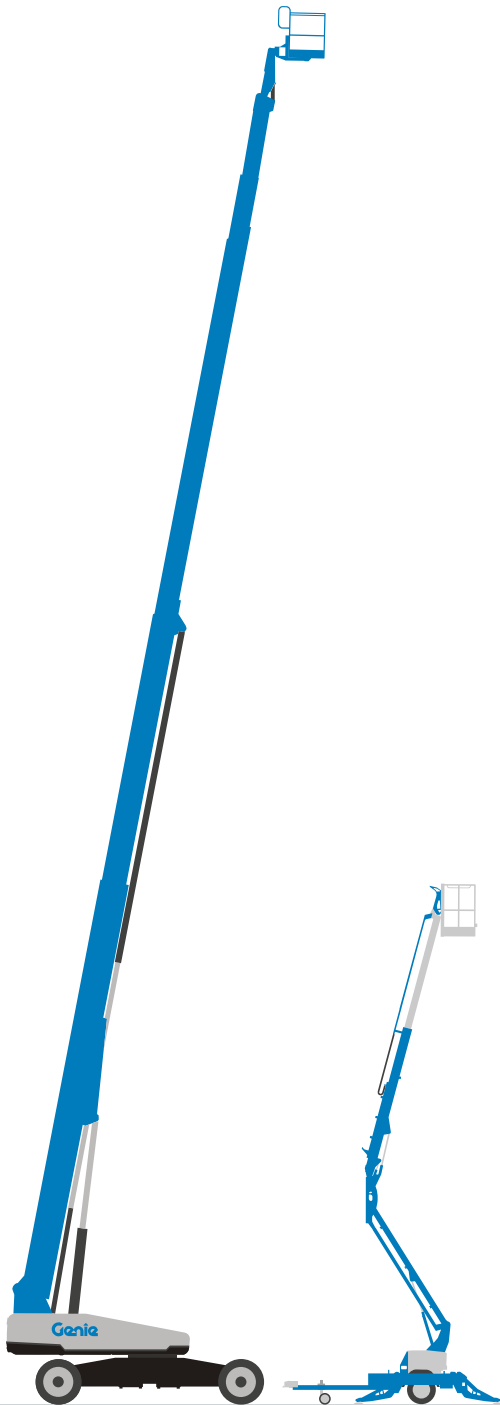

OUR STORY

QUALITY ^{BY} DESIGN™

Genie's origins date back to 1966, when Bud Bushnell bought the rights to manufacture a material lift that operated on compressed air. That "magic in a bottle" gave way to the Genie® name — and to decades of product development rooted in a genuine desire to solve real-world problems, keep people safe when they are working at height, and add value for our customers.

Today, the Genie name is synonymous with quality and our equipment and solutions can be found on jobsites around the world.

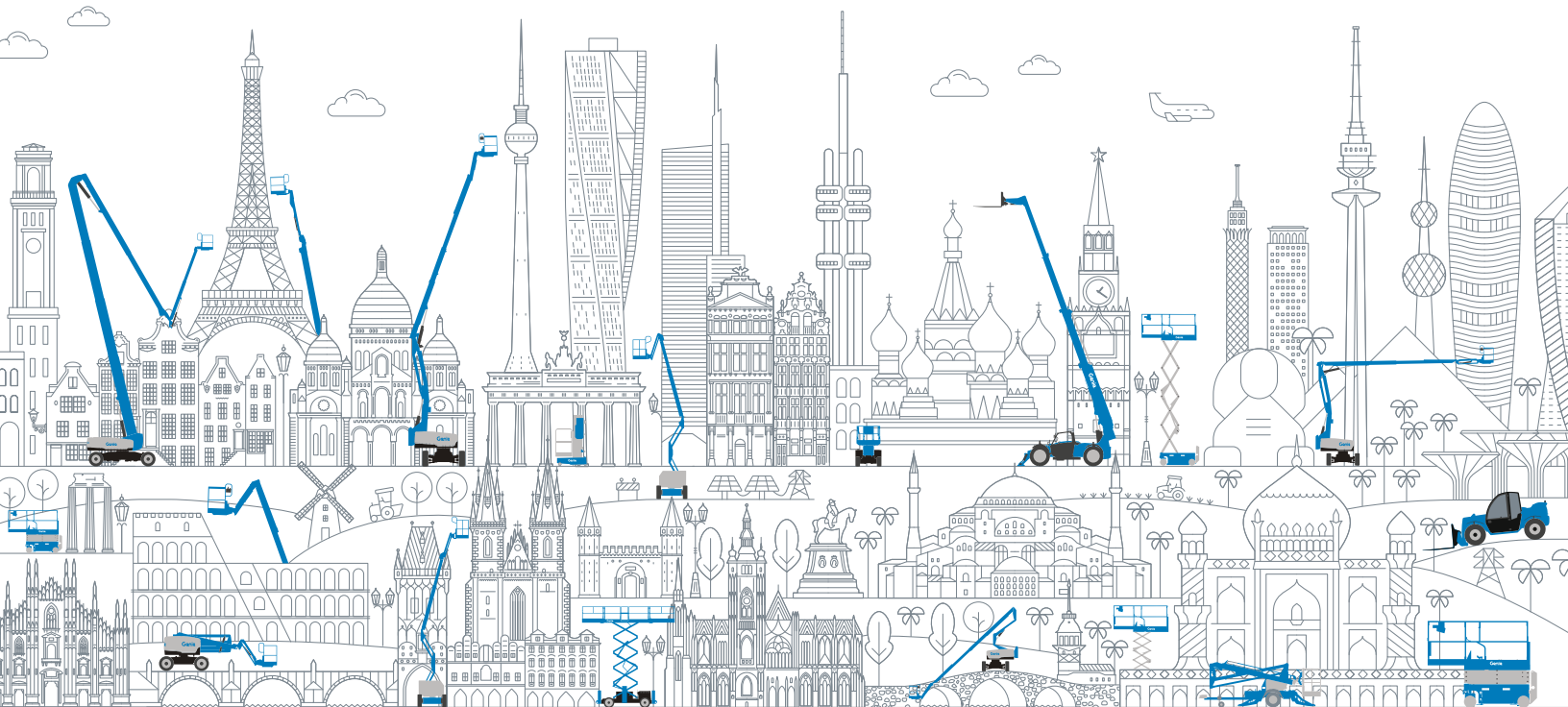



GENIE® MATERIAL LIFTS

Genie® material lifts can help move or lift heavy materials while providing operators with extra control of materials on worksites. Their portable design makes them easy to transport while also allowing them to fit effortlessly through doorways and unfinished construction spaces. Material lifts are common on construction sites for work such as installation of HVAC systems, air ducts, plumbing, and in warehouses for moving inventory. With a range of handling accessories, Genie material lifts conveniently lift loads of any shape.

**ONE
PERSON**

**TRANSPORT,
SET-UP AND
OPERATION**

**EASY
ACCESS**

**THROUGH DOORS
AND ELEVATORS**

ZERO

**MAINTENANCE
COSTS**

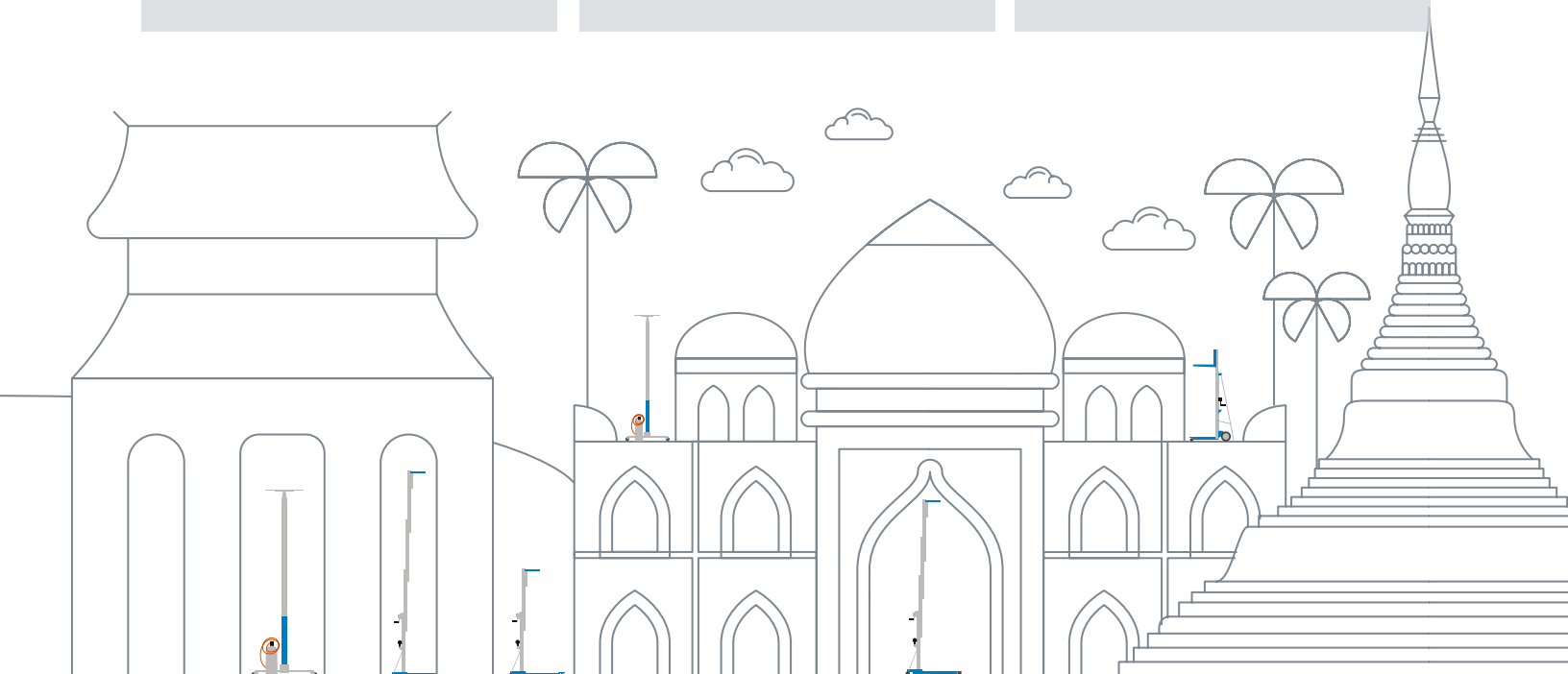



Specifications

Material Lifts

MODEL	LIFTING HEIGHT	LIFTING CAPACITY	WIDTH*	TRANSPORT LENGTH*	WEIGHT*
Super Hoist®					
GH™ 3.8	12 ft 5.6 in	350 lb	4 ft 5 in	4 ft 5 in	64 lb
GH 5.6	12 ft 5.6 in / 18 ft 4.5 in	350 lb / 150 lb	4 ft 5 in	4 ft 5 in	69 lb
Genie® Lift™					
GL™-4	5 ft 11 in	500 lb	2 ft 0.75 in	1 ft	113 lb
GL-8	10 ft 0.5 in	400 lb	2 ft 0.75 in	1 ft	132 lb
GL-10	11 ft 8 in	350 lb	2 ft 4.75 in	1 ft 7.25 in	149 lb
GL-12	13 ft 9.5 in	350 lb	2 ft 4.75 in	1 ft 7.25 in	154 lb
Superlift Contractor®					
SLC™-12	12 ft 11 in	650 lb	2 ft 7.5 in	2 ft 10 in	225 lb
SLC-18	18 ft 6 in	650 lb	2 ft 7.5 in	2 ft 10 in	307 lb
SLC-24	24 ft	650 lb	2 ft 7.5 in	2 ft 10 in	347 lb
Superlift Advantage®					
SLA™-5	6 ft 7 in	1,000 lb	2 ft 7.5 in	2 ft 5 in	215 lb
SLA-10	11 ft 5.5 in	1,000 lb	2 ft 7.5 in	2 ft 5 in	260 lb
SLA-15	16 ft 4 in	800 lb	2 ft 7.5 in	2 ft 5 in	333 lb
SLA-20	21 ft 2.5 in	800 lb	2 ft 7.5 in	2 ft 5 in	405 lb
SLA-25	26 ft 0.5 in	650 lb	2 ft 7.5 in	2 ft 7 in	450 lb

* With standard configuration. Will vary depending on options and/or country standards.

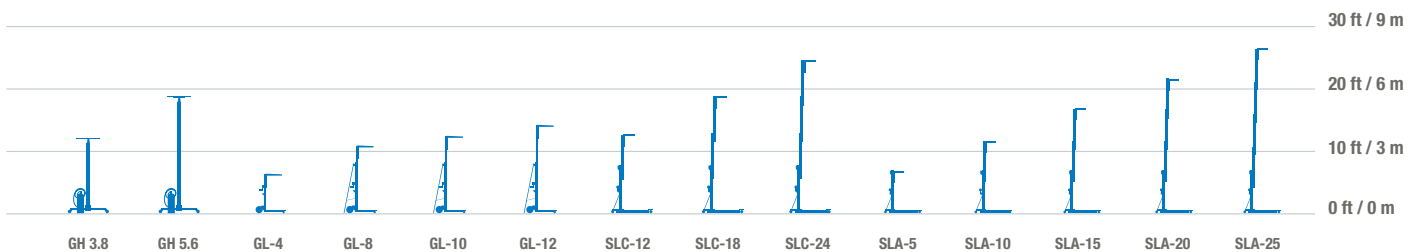

Genie® Super Hoist™ GH™ -3.8 & GH-5.6

Specifications

Models	GH-3.8		GH-5.6	
Measurements	US	METRIC	US	METRIC
A Height - stowed	3 ft 5 in	1.04 m	4 ft 6 in	1.37 m
Height - lifting height	12 ft 5.6 in	3.80 m	18 ft 4.5 in	5.60 m
B Standard base Length - platform	1 ft 4 in	0.48 m	1 ft 4 in	0.48 m
C Standard base Width - platform	2 ft	0.61 m	2 ft	0.61 m
D Width - base (corner to corner)	4 ft 5 in	1.35 m	4 ft 5 in	1.35 m
Productivity				
Load capacity	350 lb	158 kg		
Load capacity at 12 ft 5.6 in (3.8 m)			350 lb	158 kg
Load capacity at 18 ft 4.5 in (5.6 m)			150 lb	68 kg
Storage/transport dimensions	14×20× 43 in	0.36×0.51× 1.09 m	14×20× 56 in	0.36×0.51× 1.42 m
Power				
Recommended PSI	85 psi	5.86 bar	85 psi	5.86 bar
Weight and Floor Loading				
Weight	64 lb	29 kg	69 lb	31 kg

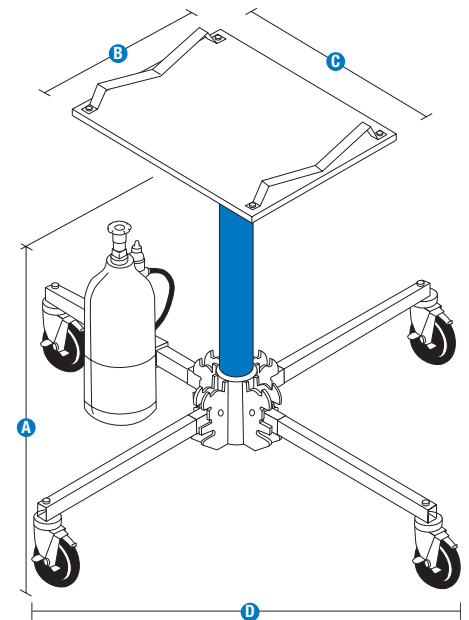

Genie® Super Hoist™ GH™ -3.8 & GH-5.6

SKU: Standard Model

- **GH380001A00001:** Super Hoist GH-3.8
- **GH560001A00001:** Super Hoist GH-5.6

* Build to Order

Option availability		S	S+	BtO
Chassis	Portable compact design for easy transport and storage	✓	✓	✓
	Powered by CO2 or compressed air	✓	✓	✓
	Quick setup requires no tools	✓	✓	✓
Mast	Auto-lubricating cylinder	✓	✓	✓
	Removable one-piece platform with a twist of the wrist	✓	✓	✓
	Up/down dump valve activated by patented control handle	✓	✓	✓
Wheels	8in/20.32cm solid non-marking wheels	✓	✓	✓
	Braking casters	✓	✓	✓
	Fold-up legs for easy storage	✓	✓	✓
Attachments	CO2 tank		○	○
	Platform cradle package		○	○

- S Standard
- S+ Standard +
- BtO Build to Order
- ✓ Standard Features
- Options



Quick Setup



Truck Portable



Lightweight



Genie Genuine Accessories⁽¹⁾

(1) More accessories available from Genie Genuine Parts.

Product specifications are subject to change without notice or obligation. Photographs and/or drawings herein are for illustrative purposes only. Refer to the appropriate Operator's Manual for instructions on proper equipment use. Failure to follow instructions in the Operator's Manual may result in serious injury or death. The only warranty applicable to our equipment is the standard written warranty applicable to the particular product and sale and we make no other warranty, express or implied. Products and services listed may be trademarks, service marks or trade names of Terex Corporation and/or their subsidiaries in the USA and many other countries. Terex, Genie, Xtra Capacity, Lift Power, Lift Guard, Lift Tools, Lift Connect and Tech Pro Link are registered trademarks of Terex Corporation or its subsidiaries.

Genie® Genie Lift™ GL™-4, GL-8, GL-10 & GL-12

Specifications

Models	GL-4		GL-8		GL-10		GL-12	
Measurements	US	METRIC	US	METRIC	US	METRIC	US	METRIC
A Height - stowed	5 ft 7.5 in	1.72 m	5 ft 7.5 in	1.72 m	6 ft 6.5 in	2.00 m	7 ft 7 in	2.31 m
Height - max. forks down	4 ft 1.5 in	1.26 m	8 ft 3 in	2.51 m	9 ft 10.5 in	3.01 m	12 ft	3.66 m
Height - max. forks up	5 ft 11 in	1.80 m	10 ft 0.5 in	3.06 m	11 ft 8 in	3.56 m	13 ft 9.5 in	4.20 m
B Standard base Length - stowed	1 ft	0.30 m	1 ft	0.30 m	—	—	—	—
B Straddle base Length - stowed	1 ft 7.25 in	0.49 m	1 ft 7.25 in	0.49 m	1 ft 7.25 in	0.49 m	1 ft 7.25 in	0.49 m
C Standard base Length - operating	2 ft 10.75 in	0.88 m	2 ft 10.75 in	0.88 m	—	—	—	—
Straddle base Length - operating	3 ft 7 in	1.09 m	3 ft 7 in	1.09 m	3 ft 7 in	1.09 m	3 ft 7 in	1.09 m
Counterweight base Length - operating	2 ft 4.5 in	0.72 m	2 ft 4.5 in	0.72 m	2 ft 4.5 in	0.72 m	—	—
C Standard base Width - platform	2 ft 0.75 in	0.63 m	2 ft 0.75 in	0.63 m	—	—	—	—
C Straddle/Counterweight base Width - stowed	2 ft 4.75 in	0.73 m	2 ft 4.75 in	0.73 m	2 ft 4.75 in	0.73 m	2 ft 4.75 in	0.73 m
C Straddle/Counterweight base Width - max.	3 ft 7.5 in	1.10 m	3 ft 7.5 in	1.10 m	3 ft 7.5 in	1.10 m	3 ft 7.5 in	1.10 m
C Straddle/Counterweight base Width - max. inside	3 ft	0.91 m	3 ft	0.91 m	3 ft	0.91 m	3 ft	0.91 m

Productivity

Load height min. (forks down)	3.5 in	9 cm	3.5 in	9 cm	3.5 in	9 cm	3.5 in	9 cm
Load height min. (straddle Base)	2 in	5.1 cm	2 in	5.1 cm	2 in	5.1 cm	2 in	5.1 cm
Ground clearance - center (1) (2) (3)	0.75 in	2 cm	0.75 in	2 cm	0.75 in	2 cm	0.75 in	2 cm
Average cranks - standard winch	11.5/ ft	38/m	11.5/ ft	38/m	11.5/ ft	38/m	11.5/ ft	38/m
Fork length	1 ft 10.5 in	0.57 m	1 ft 10.5 in	0.57 m	1 ft 10.5 in	0.57 m	1 ft 10.5 in	0.57 m
Fork width - outside	1 ft 8.5 in	0.52 m	1 ft 8.5 in	0.52 m	1 ft 8.5 in	0.52 m	1 ft 8.5 in	0.52 m
Fork width - inside	13 in	33 cm	13 in	33 cm	13 in	33 cm	13 in	33 cm
Load platform length	1 ft 11 in	0.58 m	1 ft 11 in	0.58 m	1 ft 11 in	0.58 m	1 ft 11 in	0.58 m
Load platform width	1 ft 10 in	0.56 m	1 ft 10 in	0.56 m	1 ft 10 in	0.56 m	1 ft 10 in	0.56 m
Load capacity at 14 in (36 cm) load center	500 lb	227 kg	400 lb	182 kg	350 lb	159 kg	350 lb	159 kg
Boom length	20.19 in	51 cm	20.19 in	51 cm	20.19 in	51 cm	20.19 in	51 cm
Boom attachment points	13.25/19 in	34/48 cm	13.25/19 in	34/48 cm	13.25/19 in	34/48 cm	13.25/19 in	34/48 cm

Power

Average cranks - per length unit	14/ft	46/m	14/ft	46/m	14/ft	46/m	14/ft	46/m
Standard winch - carriage moving	14/ft	46/m	14/ft	46/m	14/ft	46/m	14/ft	46/m
Standard winch - mast moving	6.5/ft	21.3/m	6.5/ft	21.3/m	6.5/ft	21.3/m	6.5/ft	21.3/m

Weight and Floor Loading

Weight - Standard base standard caster options	113 lb	51 kg	132 lb	60 kg	—	—	—	—
Weight - Standard base pneumatic caster options	117 lb	53 kg	136 lb	62 kg	—	—	—	—
Weight - Straddle base standard caster options	126 lb	57 kg	145 lb	66 kg	149 lb	68 kg	154 lb	70 kg
Weight - Straddle base pneumatic caster options	130 lb	59 kg	149 lb	68 kg	153 lb	69 kg	158 lb	72 kg
Weight - 4-point caster option A	137 lb	62 kg	158 lb	72 kg	162 lb	73 kg	167 lb	76 kg
Weight - 4-point caster option B	139 lb	63 kg	160 lb	73 kg	164 lb	75 kg	169 lb	77 kg
Weight - Counterweight base standard caster options	392 lb	178 kg	411 lb	186 kg	433 lb	196 kg	—	—

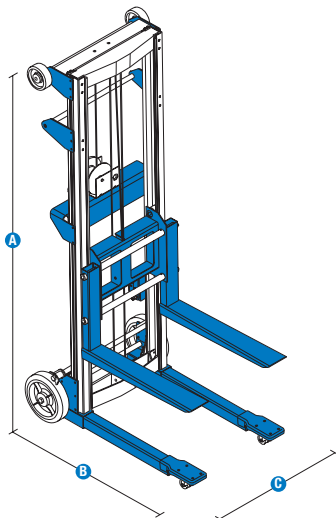

Genie® Genie Lift™ GL™-4, GL-8, GL-10 & GL-12

SKU: Standard Model

- **GL400001A00004:** GL-4 Standard base
- GL-4 Straddle base*
- GL-4 Counterweight base*

* Build to Order

SKU: Standard Model

- **GL800001A00001:** GL-8 Standard base
- GL-8 Straddle base*
- GL-8 Counterweight base*

Option availability		S	S+	BtO
Chassis	Foot-release brakes			<input type="radio"/>
	Portable compact design for easy transport and storage	<input checked="" type="checkbox"/>	<input checked="" type="checkbox"/>	<input checked="" type="checkbox"/>
	Quick setup requires no tools	<input checked="" type="checkbox"/>	<input checked="" type="checkbox"/>	<input checked="" type="checkbox"/>
	Rolls easily through single door	<input checked="" type="checkbox"/>	<input checked="" type="checkbox"/>	<input checked="" type="checkbox"/>
Mast	One-speed manual winch, locks load in place	<input checked="" type="checkbox"/>	<input checked="" type="checkbox"/>	<input checked="" type="checkbox"/>
	Reversible winch handle for easy storage	<input checked="" type="checkbox"/>	<input checked="" type="checkbox"/>	<input checked="" type="checkbox"/>
	Transport carriage lock	<input checked="" type="checkbox"/>	<input checked="" type="checkbox"/>	<input checked="" type="checkbox"/>
Wheels	10in/25.4cm pneumatic rear wheels and 2.5in/6.4cm front swivel (Standard, Straddle)			<input type="radio"/>
	4-point swivel caster A: 4in/10.2cm rear, 2in/5.1cm front (Straddle)			<input type="radio"/>
	4-point swivel caster B: 5in/12.7cm rear, 2in/6.4cm front (Straddle)			<input type="radio"/>
	5in/12cm rear swivel casters, 4in/10cm fixed front wheels (Counterweight)	<input checked="" type="checkbox"/>	<input checked="" type="checkbox"/>	<input checked="" type="checkbox"/>
	8in/20.32cm rear and 2in/5cm front, solid non-marking wheels and casters (Standard, Straddle)	<input checked="" type="checkbox"/>	<input checked="" type="checkbox"/>	<input checked="" type="checkbox"/>
Attachments	Ladder			<input type="radio"/>
	Durable standard steel forks	<input checked="" type="checkbox"/>	<input checked="" type="checkbox"/>	<input checked="" type="checkbox"/>
	Boom		<input type="radio"/>	<input type="radio"/>
	Load platform		<input type="radio"/>	<input type="radio"/>

- S Standard
- S+ Standard +
- BtO Build to Order
- Standard Features
- Options



Lightweight



Truck Portable



Material Handling Attachments



Genie Genuine Accessories⁽¹⁾

(1) More accessories available from Genie Genuine Parts.

Product specifications are subject to change without notice or obligation. Photographs and/or drawings herein are for illustrative purposes only. Refer to the appropriate Operator's Manual for instructions on proper equipment use. Failure to follow instructions in the Operator's Manual may result in serious injury or death. The only warranty applicable to our equipment is the standard written warranty applicable to the particular product and sale and we make no other warranty, express or implied. Products and services listed may be trademarks, service marks or trade names of Terex Corporation and/or their subsidiaries in the USA and many other countries. Terex, Genie, Xtra Capacity, Lift Power, Lift Guard, Lift Tools, Lift Connect and Tech Pro Link are registered trademarks of Terex Corporation or its subsidiaries.

Genie® Superlift Contractor® SLC™-12, SLC-18 & SLC-24

Specifications

Models	SLC-12		SLC-18		SLC-24	
	US	METRIC	US	METRIC	US	METRIC
Working height - standard forks (forks down)	11 ft 2 in	3.40 m	16 ft 9 in	5.10 m	22 ft 3 in	6.78 m
Working height - standard forks (forks up)	12 ft 11 in	3.94 m	18 ft 6 in	5.64 m	24 ft	7.32 m
Working height - adjustable forks (forks down)	11 ft 2 in	3.40 m	16 ft 9 in	5.10 m	22 ft 3 in	6.78 m
Working height - adjustable forks (forks up)	12 ft 11 in	3.94 m	18 ft 6 in	5.64 m	24 ft	7.32 m
Working height - boom ⁽²⁾	12 ft 2 in	3.70 m	17 ft 9 in	5.41 m	23 ft 3 in	7.10 m
A Height - stowed	7 ft 2 in	2.18 m	7 ft 2 in	2.18 m	7 ft 2 in	2.18 m
B Standard base Length - stowed	2 ft 10 in	0.86 m	2 ft 10 in	0.86 m	2 ft 10 in	0.86 m
C Standard base Length - operating	5 ft 3 in	1.60 m	6 ft 1 in	1.85 m	6 ft 9 in	2.06 m
D Width - stowed ⁽¹⁾	2 ft 7.5 in	0.80 m	2 ft 7.5 in	0.80 m	2 ft 7.5 in	0.80 m
Width - with stabilizers lowered	5 ft 6 in	1.68 m	5 ft 6 in	1.68 m	5 ft 6 in	1.68 m
E Ground clearance	2 in	5 cm	2 in	5 cm	2 in	5 cm
F Mast tilt angle	2.5° - 3° - 3.5° - 4.5°		2.5° - 3° - 3.5° - 4.5°		2.5° - 3° - 3.5° - 4.5°	
G Load height min.	6 in	15 cm	6 in	15 cm	6 in	15 cm

Productivity

Load capacity at 14 in (36 cm) load center	650 lb	295 kg	650 lb	295 kg	650 lb	295 kg
Load capacity at 24 in (61 cm) load center	425 lb	193 kg	425 lb	193 kg	425 lb	193 kg
Load capacity at 42 in (107 cm) load center	180 lb	82 kg	160 lb	73 kg	160 lb	73 kg

Power

Average cranks - per length unit	12.5/ ft	41/ m	12.5/ ft	41/ m	12.5/ ft	41/ m
Standard winch - carriage moving	12.5/ ft	41/ m	12.5/ ft	41/ m	12.5/ ft	41/ m
Standard winch - mast moving	5.5/ ft	18/ m	5.5/ ft	18/ m	5.5/ ft	18/ m

Weight and Floor Loading

Weight	225 lb	102 kg	307 lb	139 kg	347 lb	157 kg
--------	--------	--------	--------	--------	--------	--------

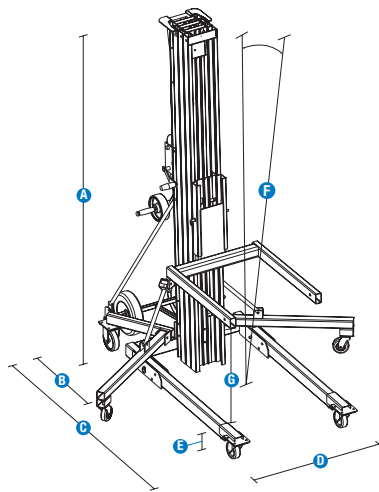

Load Handling Attachments	Dimensions		Weight	
	US	METRIC	US	METRIC
Standard forks assembly (l/w/d) ⁽³⁾	28/23/2.5 in	71/58/6 cm	26.5 lb	12 kg
Standard fork size (each)	2.5/1.5 in	6/4 cm	—	—
Adjustable forks assembly (l/w/d) ^{(3) (4)}	27.5/24-30/2.5 in	70/61-76/6 cm	52.5 lb	24 kg
Adjustable fork size max (each)	3.0/1.5 in	7/4 cm	—	—
Fork extensions detached (each) (l/w/d) ^{(3) (4)}	30/2/3 in	76/5/8 cm	4.5 lb	2 kg
Fork extension attached (each) (l/w/d) ^{(3) (4)}	35/2/3 in	64/5/8 cm	4.5 lb	2 kg
Boom (l/w/d) ^{(3) (4)}	18,24,32,44/1.5/6 in	46,61,81,112/4/15 cm	39.9 lb	18 kg
Load platform (l/w/d) ^{(3) (4)}	26.3/23/2.5 in	67/58/6 cm	23.8 lb	11 kg

(1) Outside dimensions.

(2) For use with standard and adjustable forks only.

(3) Measured from ground to bottom of shackle.

(4) Length/width/depth, from end of carriage and outside of forks

Genie® Superlift Contractor® SLC™ -12, SLC-18 & SLC-24

SKU: Standard Model

- **SLC12001A00001:** SLC-12
- **SLC18001A00001:** SLC-18, Stabilizer set
- **SLC24001A00002:** SLC-24, Stabilizer set

* Build to Order

Option availability		S	S+	BtO
Chassis	Heavy-duty design	✓	✓	✓
	Portable compact design for easy transport and storage	✓	✓	✓
	Quick setup requires no tools	✓	✓	✓
	Rear transport wheel assembly	✓	✓	✓
	Rolls easily through single door	✓	✓	✓
	Stabilizer set (standard on SLC-18, SLC-24, not on Straddle base)			○
Mast	Mast brake			○
	Glide rails allow easy loading and unloading	✓	✓	✓
	One-speed manual winch, locks load in place	✓	✓	✓
	Patented telescoping mast system	✓	✓	✓
	Strong and lightweight aluminum telescoping mast	✓	✓	✓
	Transport carriage lock	✓	✓	✓
	Two speed winch (not available on SLC-12)			○
				○
Wheels	4in/10cm non-marking front casters	✓	✓	✓
	5in/12cm rear casters with side brakes	✓	✓	✓
Attachments	Load platform		○	○
	Durable standard steel forks	✓	✓	✓
	Adjustable width forks		○	○
	Boom		○	○
	Fork extensions		○	○
Pipe cradle (available aftermarket only)		○	○	

- S Standard
- S+ Standard +
- BtO Build to Order
- ✓ Standard Features
- Options



Quick Setup



Truck Portable



Material Handling Attachments



Genie Genuine Accessories⁽¹⁾

(1) More accessories available from Genie Genuine Parts.

Product specifications are subject to change without notice or obligation. Photographs and/or drawings herein are for illustrative purposes only. Refer to the appropriate Operator's Manual for instructions on proper equipment use. Failure to follow instructions in the Operator's Manual may result in serious injury or death. The only warranty applicable to our equipment is the standard written warranty applicable to the particular product and sale and we make no other warranty, express or implied. Products and services listed may be trademarks, service marks or trade names of Terex Corporation and/or their subsidiaries in the USA and many other countries. Terex, Genie, Xtra Capacity, Lift Power, Lift Guard, Lift Tools, Lift Connect and Tech Pro Link are registered trademarks of Terex Corporation or its subsidiaries.

Genie® Superlift Advantage® SLA™ -5, SLA-10, SLA-15, SLA-20 & SLA-25

Specifications

Models	SLA-5		SLA-10		SLA-15		SLA-20		SLA-25	
	US	METRIC	US	METRIC	US	METRIC	US	METRIC	US	METRIC
Working height - standard forks (forks down)	4 ft 10.5 in	1.49 m	9 ft 9 in	2.97 m	14 ft 7.5 in	4.46 m	19 ft 6 in	5.94 m	24 ft 4 in	7.42 m
Working height - standard forks (forks up)	6 ft 7 in	2.0 m	11 ft 5.5 in	3.49 m	16 ft 4 in	4.98 m	21 ft 2.5 in	6.46 m	26 ft .5 in	7.94 m
Working height - adjustable forks (forks down)	4 ft 10.5 in	1.49 m	9 ft 9 in	2.97 m	14 ft 7.5 in	4.46 m	19 ft 6 in	5.94 m	24 ft 4 in	7.42 m
Working height - adjustable forks (forks up)	6 ft 7 in	2.0 m	11 ft 5.5 in	3.49 m	16 ft 4 in	4.98 m	21 ft 2.5 in	6.46 m	26 ft .5 in	7.94 m
Working height - flat forks	4 ft 10.5 in	1.49 m	9 ft 9 in	2.97 m	14 ft 7.5 in	4.46 m	-	-	-	-
Working height - boom ⁽³⁾	5 ft 10.5 in	1.79 m	10 ft 9 in	3.28 m	15 ft 7.5 in	4.76 m	20 ft 6 in	6.25 m	24 ft 4 in	7.42 m
Working height - load platform ⁽²⁾ - forks down	4 ft 10.5 in	1.49 m	9 ft 9 in	2.97 m	14 ft 7.5 in	4.46 m	19 ft 6 in	5.94 m	24 ft 4 in	7.42 m
Working height - load platform ⁽²⁾ - forks up	6 ft 7 in	2.0 m	11 ft 5.5 in	3.49 m	16 ft 4 in	4.98 m	21 ft 2.5 in	6.46 m	26 ft .5 in	7.94 m
A Height - stowed	6 ft 6.5 in	1.99 m	6 ft 6.5 in	1.99 m	6 ft 6.5 in	1.99 m	6 ft 6.5 in	1.99 m	6 ft 6.5 in	1.99 m
B Standard base Length - stowed	2 ft 5 in	0.74 m	2 ft 5 in	0.74 m	2 ft 5 in	0.74 m	2 ft 5 in	0.74 m	2 ft 7 in	0.79 m
C Length - operating	4 ft 11.5 in	1.51 m	4 ft 11.5 in	1.51 m	6 ft 2 in	1.88 m	6 ft 2 in	2.08 m	6 ft 10 in	2.08 m
D Width - stowed ⁽¹⁾	2 ft 7.5 in	0.80 m	2 ft 7.5 in	0.80 m	2 ft 7.5 in	0.80 m	2 ft 7.5 in	0.80 m	2 ft 7.5 in	0.80 m
Width - with stabilizers lowered	6 ft 1 in	1.85 m	6 ft 1 in	1.85 m	6 ft 1 in	1.85 m	6 ft 1 in	1.85 m	6 ft 1 in	1.85 m
E Ground clearance	2 in	5 cm	2 in	5 cm	2 in	5 cm	2 in	5 cm	2 in	5 cm
F Mast tilt angle	2.5° - 3° - 3.5° - 4.5°		2.5° - 3° - 3.5° - 4.5°		2.5° - 3° - 3.5° - 4.5°		2.5° - 3° - 3.5° - 4.5°		2.5° - 3° - 3.5° - 4.5°	
G Load height min.	6 in	15 cm	6 in	15 cm	6 in	15 cm	6 in	15 cm	6 in	15 cm

Productivity

Load capacity at 18 in (46 cm) load center	1,000 lb	454 kg	1,000 lb	454 kg	800 lb	363 kg	800 lb	363 kg	650 lb	295 kg
Load capacity at 24 in (61 cm) load center	1,000 lb	454 kg	1,000 lb	454 kg	800 lb	363 kg	600 lb	272 kg	450 lb	204 kg
Load capacity at 42 in (107 cm) load center	350 lb	159 kg	400 lb	181 kg	500 lb	227 kg	350 lb	159 kg	250 lb	113 kg

Power

Average cranks - per length unit	12.5/ft	41/m	12.5/ft	41/m	12.5/ft	41/m	12.5/ft	41/m	12.5/ft	41/m
Standard winch - carriage moving	12.5/ft	41/m	12.5/ft	41/m	12.5/ft	41/m	12.5/ft	41/m	12.5/ft	41/m
Standard winch - mast moving	5.5/ft	18/m	5.5/ft	18/m	5.5/ft	18/m	5.5/ft	18/m	5.5/ft	18/m

Weight and Floor Loading

Weight - Standard	215 lb	98 kg	260 lb	118 kg	333 lb	151 kg	405 lb	184 kg	450 lb	204 kg
Weight - Straddle base	258 lb	117 kg	303 lb	137 kg	360 lb	163 kg	-	-	-	-

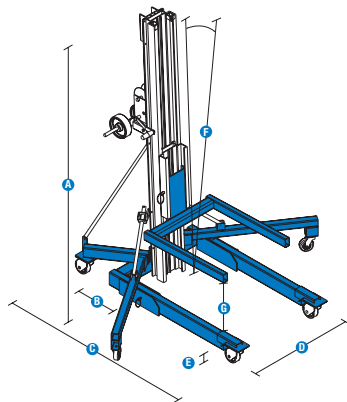

Load Handling Attachments	Dimensions		Weight	
	US	METRIC	US	METRIC
Standard forks (l/w/d) ⁽⁴⁾	27/23.5/2.5 in	69/60/6 cm	38.9 lb	18 kg
Standard fork size (each)	2.5/1.5 in	6/4 cm		
Adjustable forks assembly (l/w/d) ^{(3) (4)}	27.5/24-30/2.5 in	70/61-76/6 cm	52.5 lb	24 kg
Adjustable fork size max (each)	2.5/1.5 in	6/4 cm	52.5 lb	24 kg
Fork extensions detached (each) (l/w/d) ^{(3) (4)}	30/2/3 in	76/5/8 cm	4.5 lb	2 kg
Fork extension attached (each) (l/w/d) ^{(3) (4)}	25/2/3 in	64/5/8 cm	4.5 lb	2 kg
Flat forks (l/w/d) ⁽⁴⁾	32/16-31/1.5 in	81/41-79/3.8 cm	80.1 lb	36 kg
Boom (l/w/d) ^{(3) (4)}	18,24,32,44/1.5/6 in	46,61,81,112/4/15 cm	39.9 lb	18 kg
Load platform (l/w/d) ^{(3) (4)}	27.5/23/2.75 in	70/58/7 cm	31.5 lb	14 kg

(1) Outside dimensions.

(2) For use with standard and adjustable forks only.

(3) Measured from ground to bottom of shackle.

(4) Length/width/depth, from end of carriage and outside of forks

Genie® Superlift Advantage® SLA™ -5, SLA-10, SLA-15, SLA-20 & SLA-25

SKU: Standard Model

- SLA-5, Standard base*
- **SLA50001A00002:** SLA-5, Straddle base
- **SLA10001A00001:** SLA-10, Standard base
- **SLA10001A00002:** SLA-10, Straddle base

* Build to Order

SKU: Standard Model

- **SLA15001A00001:** SLA-15, Standard base
- SLA-15, Straddle base*
- **SLA20001A00001:** SLA-20, Standard base, Stabilizer set
- **SLA25001A00001:** SLA-25, Standard base, Stabilizer set

Option availability		S	S+	BtO
Chassis	Rear transport wheel assembly			○
	Heavy-duty design	✓	✓	✓
	Portable compact design for easy transport and storage	✓	✓	✓
	Quick setup requires no tools	✓	✓	✓
	Stabilizer set (standard on SLA-20, SLA-25, not on Straddle base)			○
Mast	Mast brake			○
	One-speed manual winch, locks load in place	✓	✓	✓
	Patented telescoping mast system	✓	✓	✓
	Strong and lightweight aluminum telescoping mast	✓	✓	✓
	Transport carriage lock	✓	✓	✓
Two speed winch (SLA-15, SLA-20, SLA-25 only)			○	
Wheels	4in/10cm non-marking front casters	✓	✓	✓
	5in/12cm rear casters with side brakes	✓	✓	✓
Attachments	Durable standard steel forks	✓	✓	✓
	Adjustable width forks		○	○
	Boom		○	○
	Flat forks (SLA-5, SLA-10, SLA-15)		○	○
	Fork extensions (use on Standard or Adjustable forks)		○	○
Load platform		○	○	

- S Standard
- S+ Standard +
- BtO Build to Order
- ✓ Standard Features
- Options



Quick Setup



Truck Portable



Max Lift Capacity
1000lb/454kg



Genie Genuine Accessories⁽¹⁾

(1) More accessories available from Genie Genuine Parts.

Product specifications are subject to change without notice or obligation. Photographs and/or drawings herein are for illustrative purposes only. Refer to the appropriate Operator's Manual for instructions on proper equipment use. Failure to follow instructions in the Operator's Manual may result in serious injury or death. The only warranty applicable to our equipment is the standard written warranty applicable to the particular product and sale and we make no other warranty, express or implied. Products and services listed may be trademarks, service marks or trade names of Terex Corporation and/or their subsidiaries in the USA and many other countries. Terex, Genie, Xtra Capacity, Lift Power, Lift Guard, Lift Tools, Lift Connect and Tech Pro Link are registered trademarks of Terex Corporation or its subsidiaries.

GENIE® AERIAL WORK PLATFORMS

Compact enough to work indoors without compromising on reach, Genie® push-around aerial work platforms are popular options for work at height in schools, warehouses, hospitals, and more. Aerial work platforms can be used by one operator for maintenance inspections, small repair jobs, and other projects throughout a building. Their compact designs also make them easy to transport through small spaces like doorways and elevators.

ONE PERSON

TRANSPORT,
SET-UP AND
OPERATION

EASY ACCESS

THROUGH DOORS
AND ELEVATORS

COMPACT FOOTPRINT

SMALLEST
IN ITS CLASS





Specifications

Aerial Work Platforms

MODEL	MAX. PLATFORM HEIGHT	LIFT CAPACITY	WIDTH*	TRANSPORT LENGTH*	WEIGHT*
Aerial Work Platforms					
AWP®-20S	20 ft 1 in	350 lb	2 ft 5 in	4 ft 1 in	677 lb
AWP-25S	24 ft 9 in	350 lb	2 ft 5 in	4 ft 3.5 in	727 lb
AWP-30S	29 ft 6 in	350 lb	2 ft 5 in	4 ft 5 in	777 lb
AWP-36S	36 ft 5 in	350 lb	2 ft 5 in	4 ft 7 in	1,017 lb
AWP-40S	40 ft 3 in	300 lb	2 ft 5 in	4 ft 8 in	1,040 lb

* With standard configuration. Will vary depending on options and/or country standards.

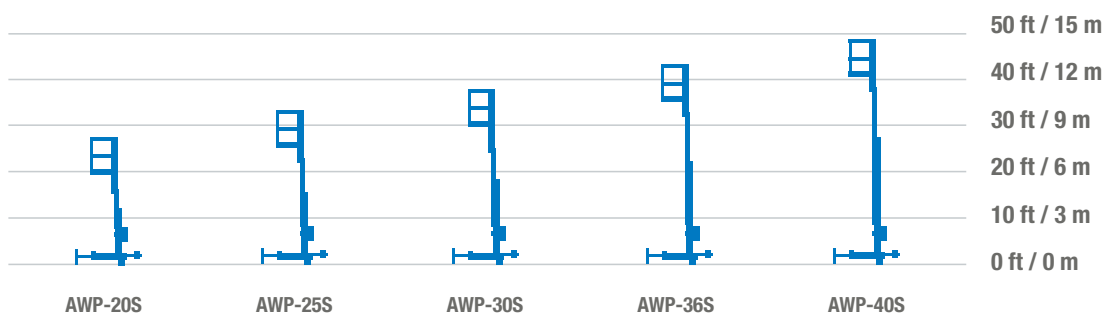

Genie® AWP™-20S, AWP-25S, AWP-30S, AWP-36S & AWP-40S

Specifications

Models	AWP-20S		AWP-25S		AWP-30S	
Measurements	US	METRIC	US	METRIC	US	METRIC
Working height max. ⁽¹⁾	26 ft 1 in	8.10 m	30 ft 9 in	9.50 m	35 ft 6 in	11.0 m
Platform height	20 ft 1 in	6.10 m	24 ft 9 in	7.50 m	29 ft 6 in	9.00 m
A Height - stowed (standard)	6 ft 6 in	1.98 m	6 ft 6 in	1.98 m	6 ft 6 in	1.98 m
B Height Tilted back ⁽²⁾ (standard)	-	-	-	-	-	-
C Length - stowed (standard)	4 ft 1 in	1.24 m	4 ft 3.5 in	1.31 m	4 ft 5 in	1.35 m
D Length - tilted back ⁽²⁾	-	-	-	-	-	-
E Width	2 ft 5 in	0.74 m	2 ft 5 in	0.74 m	2 ft 5 in	0.74 m

Productivity

Lift capacity	350 lb	159 kg	350 lb	159 kg	350 lb	159 kg
F G Outrigger footprint (l/w) (standard)	5 ft 1 in/4 ft 5 in	1.55/1.35 m	5 ft 9 in/5 ft 1 in	1.75/1.55 m	6 ft 4 in/5 ft 8 in	1.93/1.73 m
H Corner access ⁽³⁾ (standard)	1 ft 3 in	0.38 m	1 ft 7 in	0.48 m	1 ft 10 in	0.56 m
I J Wall access front/side (standard)	6 in/1 ft 1 in	0.15/0.33 m	7 in/1 ft 5 in	0.18/0.43 m	8 in/1 ft 9 in	0.20/0.53 m
Standard platform dimensions (l/w/h)	27/26/44.75 in	0.69/0.66/1.14 m	27/26/44.75 in	0.69/0.66/1.14 m	27/26/44.75 in	0.69/0.66/1.14 m
Gated standard platform dimensions (l/w/h)	27/26/44.75 in	0.69/0.66/1.14 m	27/26/44.75 in	0.69/0.66/1.14 m	27/26/44.75 in	0.69/0.66/1.14 m
Gated narrow platform dimensions (l/w/h)	26/20/44.75 in	0.66/0.51/1.14 m	26/20/44.75 in	0.66/0.51/1.14 m	26/20/44.75 in	0.66/0.51/1.14 m

Weight and Floor Loading⁽⁴⁾

AC models	677 lb	307 kg	727 lb	330 kg	777 lb	352 kg
DC models	766 lb	347 kg	817 lb	371 kg	867 lb	393 kg
Occupied floor pressure	0.35 psi	2.40 kPa	0.28 psi	1.90 kPa	0.24 psi	1.65 kPa

Models	AWP-36S		AWP-40S	
Measurements	US	METRIC	US	METRIC
Working height max. ⁽¹⁾	42 ft 5 in	13.10 m	46 ft 3 in	14.30 m
Platform height	36 ft 5 in	11.10 m	40 ft 3 in	12.30 m
A Height - stowed (standard)	9 ft 1.5 in	2.78 m	9 ft 1.5 in	2.78 m
B Height Tilted back ⁽²⁾ (standard)	6 ft 3.5 in	1.92 m	6 ft 6 in	1.98 m
C Length - stowed (standard)	4 ft 7 in	1.40 m	4 ft 8 in	1.42 m
D Length - tilted back ⁽²⁾	9 ft 9 in	2.97 m	9 ft 9 in	2.97 m
E Width	2 ft 5 in	0.74 m	2 ft 5 in	0.74 m

Productivity

Lift capacity	350 lb	159 kg	300 lb	136 kg
F G Outrigger footprint (l/w) (standard)	6 ft 11 in/6 ft 3 in	2.12/1.91 m	7 ft 5 in/6 ft 9 in	2.26/2.06 m
H Corner access ⁽³⁾ (standard)	2 ft 5 in	0.74 m	2 ft 7 in	0.79 m
I J Wall access front/side (standard)	1 ft 2 in/2 ft 1 in	0.36/0.64 m	1 ft 3 in/2 ft 4 in	0.38/0.71 m
Standard platform dimensions (l/w/h)	27/26/44.75 in	0.69/0.66/1.14 m	27/26/44.75 in	0.69/0.66/1.14 m
Gated standard platform dimensions (l/w/h)	27/26/44.75 in	0.69/0.66/1.14 m	27/26/44.75 in	0.69/0.66/1.14 m
Gated narrow platform dimensions (l/w/h)	26/20/44.75 in	0.66/0.51/1.14 m	26/20/44.75 in	0.66/0.51/1.14 m

Weight and Floor Loading⁽⁴⁾

AC models	1,017 lb	461 kg	1,040 lb	472 kg
DC models	1,107 lb	502 kg	1,130 lb	513 kg
Occupied floor pressure	0.23 psi	1.60 kPa	0.20 psi	1.37 kPa

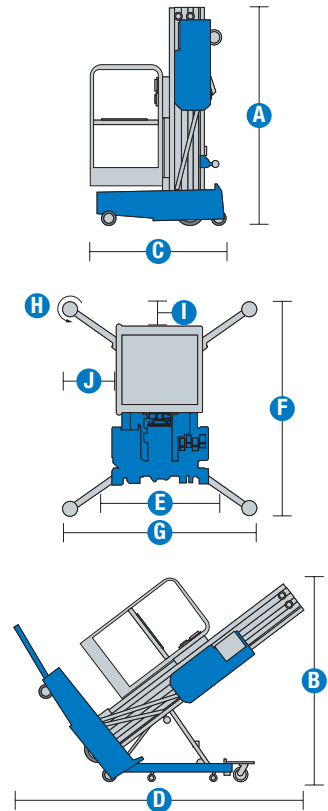

Power

Power source - AC models	110V/50-60 Hz 220V/50-60 Hz
Power source - DC models	12V DC

Sound and Vibration Levels

Sound Pressure level (ground workstation)	< 70 dBA
Sound Pressure level (platform workstation)	< 70 dBA
Vibrations	< 2.5 m/s ²

(1) The metric equivalent of working height adds 2m to platform height. U.S. adds 6ft to platform height.

(2) Gradeability applies to driving on slopes and may vary depending on options and machine configurations. See operator's manual for details regarding slope ratings.

(3) Weight refers to standard configuration and may vary depending on options and/or country standards.

(4) Floor loading information is approximate and may vary depending on options and machine configurations. It should be used only with adequate safety factors.

Genie® AWP™-20S, AWP-25S, AWP-30S, AWP-36S & AWP-40S

SKU: Stock Models

- AWP-20S, AC Power*
- AWP-25S, AC Power*
- AWP-30S, AC Power*
- AWP-36S, AC Power with Tilt-back frame*
- AWP-40S, AC Power with Tilt-back frame*

SKU: Stock Models

- AWP-20S, DC Power*
- **AWP25S01AE0001:** AWP-25S, DC Power
- **AWP30S01AE0001:** AWP-30S, DC Power
- AWP-36S, DC Power with Tilt-back frame*
- **AWP40S01AE0001:** AWP-40S, DC Power with Tilt-back frame

* Build to Order

Option availability	S	S+	BtO
Power			
AC 85V power			○
Wet battery (DC - only for AWP-30S)	✓	✓	✓
AC 110V power	✓	✓	✓
AC 220V power			○
DC Power	✓	✓	✓
Dry battery (DC)		○	○
12V 110/230V 50-60Hz worldwide smart charging system	✓	✓	✓
Platform			
Sliding mid-rail standard platform	✓	✓	✓
Gated standard platform			○
Gated narrow platform			○
Descent light and alarm package		○	○
Tool tray		○	○
AC power to platform	✓	✓	✓
Chassis			
Standard base for all models	✓	✓	✓
Long cord 79"		○	○
Lift Guard White Noise Alarm		○	○
Auxiliary platform lowering	✓	✓	✓
Crane attachment point	✓	✓	✓
Easy operation: rolls through standard doorways	✓	✓	✓
Fast load into pickup trucks	✓	✓	✓
Forklift pockets (Standard base only)	✓	✓	✓
Ground fault interrupt	✓	✓	✓
Heavy-duty design and mast	✓	✓	✓
LED lights confirm proper set-up	✓	✓	✓
Outrigger storage pockets	✓	✓	✓
Rocker base system for maneuverability	✓	✓	✓
Standard outriggers	✓	✓	✓
Tie-down attachment points	✓	✓	✓

- S Standard
- S+ Standard +
- BtO Build to Order
- ✓ Standard Features
- Options



Lightweight



Easy to Load and Transport



Low Floor Loading

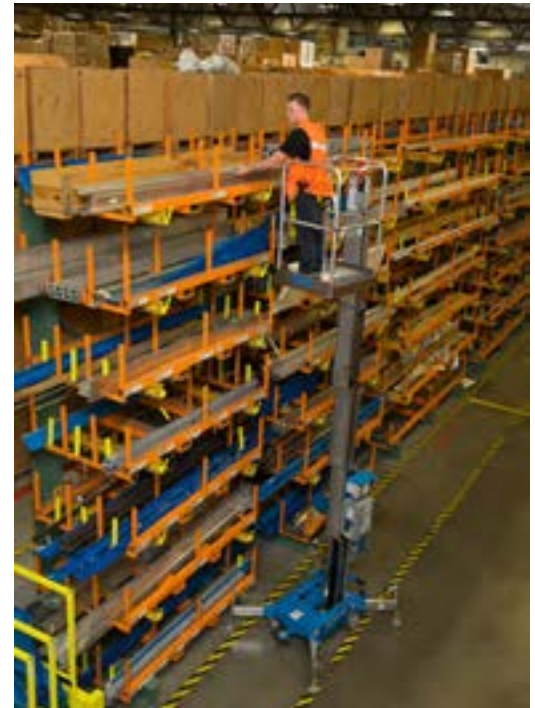

Genie Genuine Accessories⁽¹⁾

- Platform-locating laser light
- Fluorescent tube caddy

⁽¹⁾ More accessories available from Genie Genuine Parts.

Product specifications are subject to change without notice or obligation. Photographs and/or drawings herein are for illustrative purposes only. Refer to the appropriate Operator's Manual for instructions on proper equipment use. Failure to follow instructions in the Operator's Manual may result in serious injury or death. The only warranty applicable to our equipment is the standard written warranty applicable to the particular product and sale and we make no other warranty, express or implied. Products and services listed may be trademarks, service marks or trade names of Terex Corporation and/or their subsidiaries in the USA and many other countries. Terex, Genie, Xtra Capacity, Lift Power, Lift Guard, Lift Tools, Lift Connect and Tech Pro Link are registered trademarks of Terex Corporation or its subsidiaries.

GENIE® VERTICAL MAST LIFTS

The self-propelled Genie® Runabout™ range offers versatile solutions for low-level access jobs in warehouses, data centres and hospitality applications. Ideal for general maintenance and painting, the Runabout range can be used on sensitive floors thanks to their low floor pressure. Models with jib offer extra versatility when additional outreach is needed in congested jobsites.

INTUITIVE

2-IN-1 CONTROL
& DIAGNOSTIC
SYSTEM

PROVEN

MAST DESIGN

ENHANCED

OPERATOR
EFFICIENCY
& ERGONOMICS

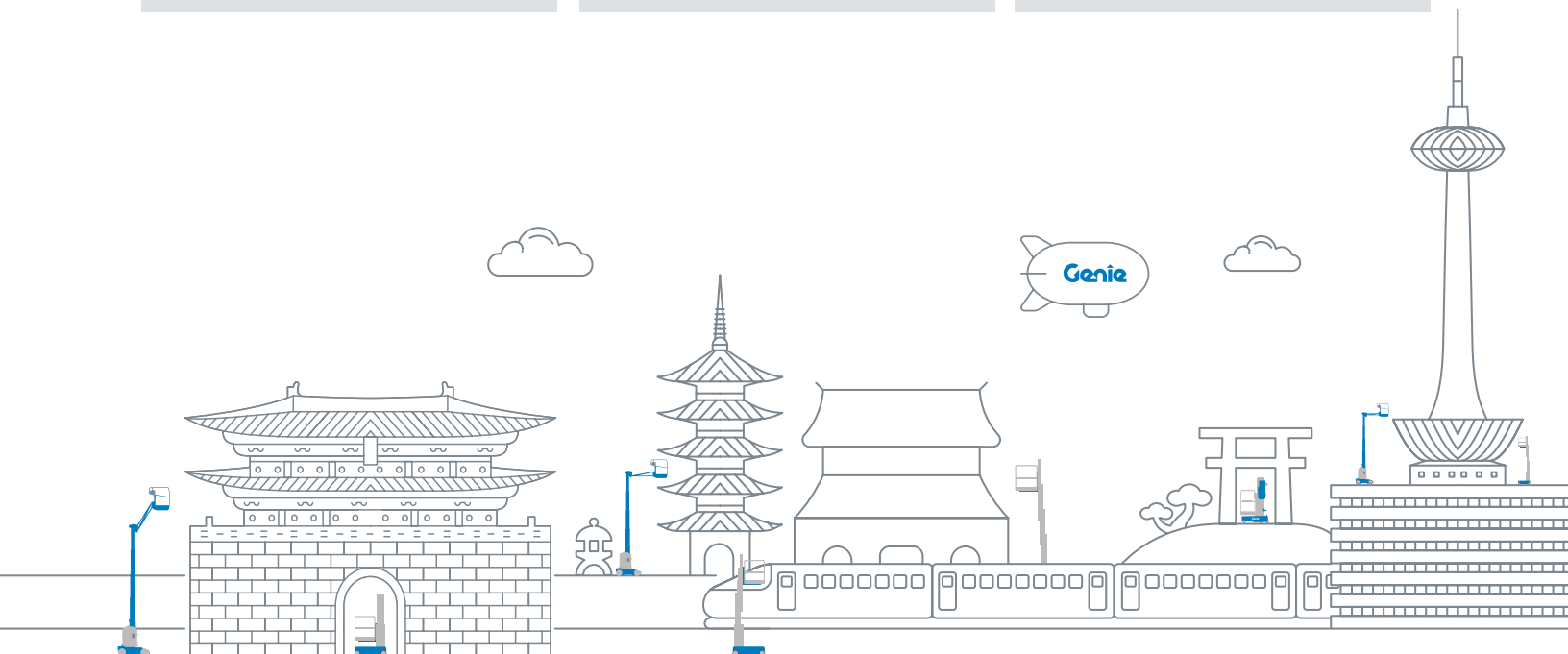



480 VOLTS
THREE PHASE

Genie Runabout

Genie GR-20

Specifications

Vertical Mast Lifts

MODEL	MAX. PLATFORM HEIGHT	LIFT CAPACITY	WIDTH*	TRANSPORT LENGTH*	WEIGHT*
Self-Propelled Aerial Work Platforms (Genie® Runabout™ Family)					
GR™-12	11 ft 4 in	500 lb	2 ft 5.5 in	4 ft 5 in	1,681 lb
GR-15	14 ft 8 in	500 lb	2 ft 5.5 in	4 ft 5 in	2,178 lb
GR-20	19 ft 9 in	350 lb	2 ft 7.5 in	4 ft 5 in	2,513 lb
Self-Propelled Aerial Work Platform with Jib (Genie Runabout Family)					
GR-26J	25 ft 11 in	440 lb	3 ft 3 in	9 ft 3 in	5,842 lb

* With standard configuration. Will vary depending on options and/or country standards.

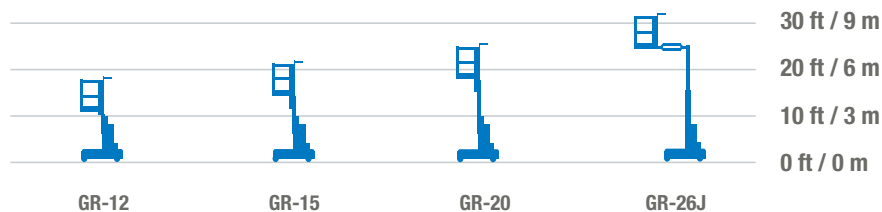

Genie® GR-12, GR-15 & GR-20

Specifications

Models	GR-12		GR-15		GR-20	
	US	METRIC	US	METRIC	US	METRIC
Working height max. - indoor ⁽¹⁾	17 ft 4 in	5.45 m	20 ft 8 in	6.47 m	25 ft 9 in	8.02 m
Working height max. - outdoor ⁽¹⁾	15 ft 1 in	4.80 m	17 ft 1 in	5.40 m	21 ft 6 in	6.70 m
Platform height max.- indoor	11 ft 4 in	3.45 m	14 ft 8 in	4.47 m	19 ft 9 in	6.02 m
Platform height max. - outdoor	9 ft 1 in	2.80 m	11 ft 1 in	3.40 m	15 ft 6 in	4.70 m
A B Platform dimensions (lengthxwidth) - Standard retracted	35x29.5 in	0.89x0.75 m	35x29.5 in	0.89x0.75 m	35x29.5 in	0.89x0.75 m
Platform dimensions (lengthxwidth) - Standard extended	55x29.5 in	1.4x0.75 m	55x29.5 in	1.4x0.75 m	55x29.5 in	1.4x0.75 m
C Height - stowed	5 ft 10 in	1.78 m	5 ft 10 in	1.78 m	6 ft 6 in	1.98 m
D Length- stowed	4 ft 5 in	1.35 m	4 ft 5 in	1.35 m	4 ft 5 in	1.35 m
E Width	2 ft 5.5 in	0.75 m	2 ft 5.5 in	0.75 m	2 ft 7.5 in	0.80 m
F Ground clearance (center)	2.5 in	6 cm	2.5 in	6 cm	2.5 in	6 cm

Productivity

Maximum platform occupancy (in/out)	1/1		1/1		1/1	
Lift capacity	500 lb	227 kg	500 lb	227 kg	350 lb	159 kg
Lift capacity - extension deck extended	250 lb	113 kg	250 lb	113 kg	250 lb	113 kg
Drive speed - stowed	2.5 mph	4.0 km/h	2.5 mph	4.0 km/h	2.5 mph	4.0 km/h
Drive speed - raised	0.5 mph	0.8 km/h	0.5 mph	0.8 km/h	0.5 mph	0.8 km/h
Gradeability ⁽²⁾	30%		30%		30%	
Turning radius - inside	0 in	0 cm	0 in	0 cm	0 in	0 cm
Turning radius - outside	4 ft 4 in	1.32 m	4 ft 4 in	1.32 m	4 ft 4 in	1.32 m
Lifting speed - raise/lower	20/18 sec		21/19 sec		24/21 sec	
Controls - proportional	24V DC		24V DC		24V DC	
Tires - Solid non-marking	10x3x8 in	25x8x20 cm	10x3x8 in	25x8x20 cm	10x3x8 in	25x8x20 cm
Tilt sensor activation (front to back/side to side)	3°/1.5°		3°/1.5°		3°/1.5°	

Power

Power	24V (4x6V 225Ah)		24V (4x6V 225Ah)		24V (4x6V 225Ah)	
Hydraulic tank capacity	2.2 gal	8.33 L	2.2 gal	8.33 L	2.2 gal	8.33 L

Weight(3) and Floor Loading⁽⁴⁾

Weight	1,681 lb	763 kg	2,178 lb	988 kg	2,513 lb	1,140 kg
Tire load max.	680 lb	308 kg	720 lb	327 kg	870 lb	395 kg
Tire contact pressure	104.6 psi	721.3 KPa	110.8 psi	763.7 Kpa	133.8 psi	922.8 Kpa
Occupied floor pressure	200.87 psf	9.6 kPa	251.99 psf	12.1 kPa	250.39 psf	12.0 kPa

Sound and Vibration Levels

Sound Pressure level (ground workstation)	< 70 dBA		< 70 dBA		< 70 dBA	
Sound Pressure level (platform workstation)	< 70 dBA		< 70 dBA		< 70 dBA	
Vibrations	< 8 ft 2 in/s ²	< 2.5 m/s ²	< 8 ft 2 in/s ²	< 2.5 m/s ²	< 8 ft 2 in/s ²	< 2.5 m/s ²

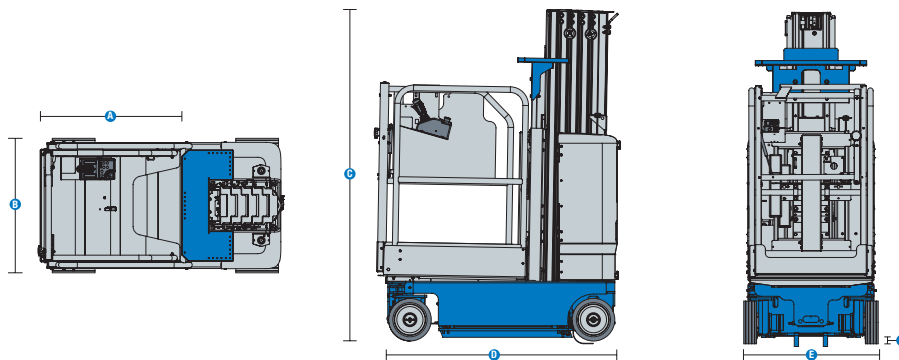

(1) The metric equivalent of working height adds 2 m to platform height. U.S. adds 6 ft to platform height.

(2) Gradeability applies to driving on slopes and may vary depending on options and machine configurations. See operator's manual for details regarding slope ratings.

(3) Weight refers to standard configuration and may vary depending on options and/or country standards.

(4) Floor loading information is approximate and may vary depending on options and machine configurations. It should be used only with adequate safety factors.

Genie® GR-12, GR-15 & GR-20

SKU: Standard Model

- **GR120001AE0001:** GR-12, Gated extension platform
- **GR150001AE0002:** GR-15, Gated extension platform
- **GR200001AE0001:** GR-20, Gated extension platform

* Build to Order

Option availability		S	S+	BtO
Power	Standard FLA flood lead acid batteries	✓	✓	✓
	AGM maintenance-free batteries		○	○
	Power inverter		○	○
	Retractable Charging cord		○	○
Platform	Sliding mid-rail standard aluminum platform			○
	Sliding mid-rail extension aluminum platform			○
	Gated extension aluminum platform	✓	✓	✓
	Automotive-style horn		○	○
	Lift Tools Work Tray		○	○
	AC power to platform	✓	✓	✓
	Auxiliary platform lowering	✓	✓	✓
	Platform control guard	✓	✓	✓
	Platform load sense system	✓	✓	✓
	Proportional lift and drive	✓	✓	✓
	SmartLink dual zone control system	✓	✓	✓
Chassis	Lift Connect Telematics		○	○
	Lift Connect with Access Manager upgrade		○	○
	Biodegradable hydraulic oil			○
	Drive cut-out while charging		○	○
	Lift Guard White Noise Alarm		○	○
	Descent, tilt, and motion alarm	✓	✓	✓
	Dual LED flashing beacons	✓	✓	✓
	Dual wheel multi-disc brakes	✓	✓	✓
	Hinged rear ABS covers for easy access	✓	✓	✓
	Hour meter	✓	✓	✓
	Hydraulic brake release	✓	✓	✓
	Large forklift pockets access	✓	✓	✓
	Lift Tools Spill Guard	✓	✓	✓
	On-board diagnostic system with battery charge indicator	✓	✓	✓
	Overhead crane attachment point	✓	✓	✓
	Pothole protection	✓	✓	✓
	Solid non-marking tires	✓	✓	✓
Tech Pro Link connector	✓	✓	✓	
Tie-down attachment points	✓	✓	✓	

- S Standard
- S+ Standard +
- BtO Build to Order
- ✓ Standard Features
- Options



Zero Inside Turning Radius



Narrow Access



Low Entry Height



Genie Genuine Accessories⁽¹⁾

- Lift Tools productivity tools
- Lift Connect Telematics subscription extension
- Tech Pro Link Connector

(1) More accessories available from Genie Genuine Parts.

Product specifications are subject to change without notice or obligation. Photographs and/or drawings herein are for illustrative purposes only. Refer to the appropriate Operator's Manual for instructions on proper equipment use. Failure to follow instructions in the Operator's Manual may result in serious injury or death. The only warranty applicable to our equipment is the standard written warranty applicable to the particular product and sale and we make no other warranty, express or implied. Products and services listed may be trademarks, service marks or trade names of Terex Corporation and/or their subsidiaries in the USA and many other countries. Terex, Genie, Quality By Design, Xtra Capacity, Lift Power, Lift Guard, Lift Tools, Lift Connect and Tech Pro Link are registered trademarks of Terex Corporation or its subsidiaries.



Genie® GR-26J

Specifications

Models	GR-26J	
Measurements	US	METRIC
Working height max. - indoor ⁽¹⁾	31 ft 11 in	9.90 m
Working height max. - outdoor ⁽¹⁾	31 ft 11 in	9.90 m
Platform height max.- indoor	25 ft 11 in	7.90 m
Platform height max. - outdoor	25 ft 11 in	7.90 m
Horizontal reach max.	8 ft 8 in	2.65 m
Working horizontal reach max.	10 ft 3 in	3.15 m
Up-and-over clearance max.	21 ft 10 in	6.70 m
A Platform length	2 ft 5.5 in	0.75 m
B Platform width	2 ft 11 in	0.90 m
Toeboard Height	6 in	15 cm
C Height - stowed	6 ft 6 in	1.99 m
D Length- stowed	9 ft 3 in	2.82 m
E Width	3 ft 3 in	0.99 m
F Wheelbase	3 ft 11 in	1.2 m
G Ground clearance (center)	4 in	10 cm

Productivity

Maximum platform occupancy (in/out)	2/1	
Lift capacity	440 lb	200 kg
Lift capacity - extension deck extended	300 lb	136 kg
Vertical jib rotation	140°	
Turntable rotation	350°	
Drive speed - stowed	2.8 mph	4.5 km/h
Drive speed - raised	0.4 mph	0.65 km/h
Gradeability ⁽²⁾	25%	
Turning radius - inside	1 ft 11 in	59 cm
Turning radius - outside	6 ft 10 in	2.08 m
Lifting speed - raise/lower	54/40 sec	
Controls - proportional	24V DC	
Tires - Solid non-marking	16×5×11.25 in	40.5 cm

Power

Power	24V (12×2V 250Ah)	
Hydraulic tank capacity	4.84 gal	22L

Weight⁽³⁾ and Floor Loading⁽⁴⁾

Weight	5,842 lb	2,650 kg
Tire load max.	3,273 lb	1,485 kg
Occupied floor pressure	420 psf	2,054 kg/m ²

Sound and Vibration Levels

Sound Pressure level (ground workstation)	< 70 dBA	
Sound Pressure level (platform workstation)	< 70 dBA	
Vibrations	< 8 ft 2 in/s ²	< 2.5 m/s ²

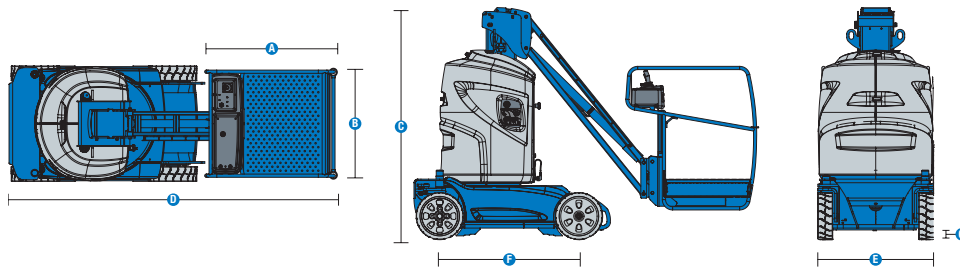

(1) The metric equivalent of working height adds 2m to platform height. U.S. adds 6ft to platform height.

(2) Gradeability applies to driving on slopes and may vary depending on options and machine configurations. See operator's manual for details regarding slope ratings.

(3) Weight refers to standard configuration and may vary depending on options and/or country standards.

(4) Floor loading information is approximate and may vary depending on options and machine configurations. It should be used only with adequate safety factors.

Range of motion GR-26J

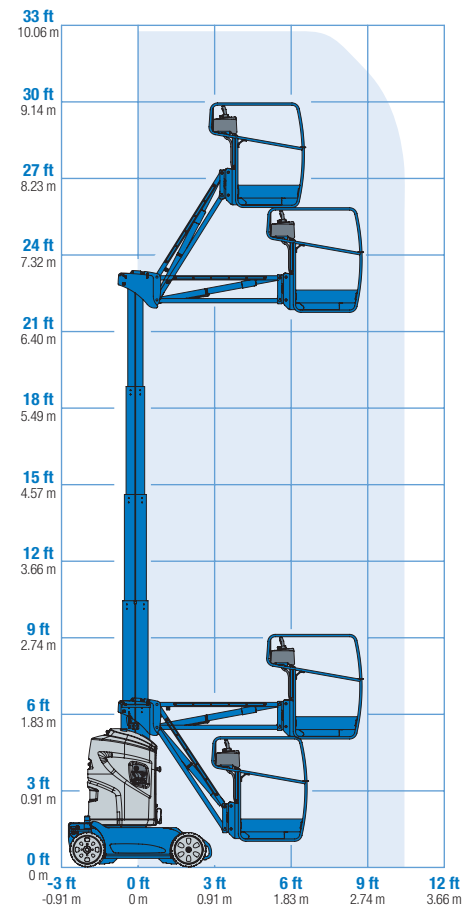

Genie® GR-26J

SKU: Standard Model

- GR26J001AD0004: GR-26J

* Build to Order

Option availability		S	S+	BtO
Power	24V DC, twelve 2V batteries, 250Ah capacity	✓	✓	✓
Platform	Steel sliding mid-rail platform	✓	✓	✓
	Steel tube-in-tube mast system	✓	✓	✓
	AC power to platform		○	○
	Auxiliary platform lowering	✓	✓	✓
	Platform load sense system	✓	✓	✓
	Proportional lift and drive	✓	✓	✓
Chassis	Flashing beacon	✓	✓	✓
	Descent, tilt, and motion alarm	✓	✓	✓
	Direct electric rear wheel drive	✓	✓	✓
	Drive enable system	✓	✓	✓
	Electric brake release	✓	✓	✓
	Fork pockets	✓	✓	✓
	Front wheel steer	✓	✓	✓
	Hour meter	✓	✓	✓
	On-board diagnostic system with battery charge indicator	✓	✓	✓
	Pothole protection	✓	✓	✓
	Reinforced ABS chassis covers	✓	✓	✓
	Solid non-marking tires	✓	✓	✓
	Tie-down attachment points	✓	✓	✓

- S Standard
- S+ Standard +
- BtO Build to Order
- ✓ Standard Features
- Options



Indoor & Outdoor



Narrow Access



Proportional lift and drive



Genie Genuine Accessories⁽¹⁾

- Lift Tools productivity tools
- Lift Connect Telematics subscription extension
- Tech Pro Link Connector

(1) More accessories available from Genie Genuine Parts.

Product specifications are subject to change without notice or obligation. Photographs and/or drawings herein are for illustrative purposes only. Refer to the appropriate Operator's Manual for instructions on proper equipment use. Failure to follow instructions in the Operator's Manual may result in serious injury or death. The only warranty applicable to our equipment is the standard written warranty applicable to the particular product and sale and we make no other warranty, express or implied. Products and services listed may be trademarks, service marks or trade names of Terex Corporation and/or their subsidiaries in the USA and many other countries. Terex, Genie, Quality By Design, Xtra Capacity, Lift Power, Lift Guard, Lift Tools, Lift Connect and Tech Pro Link are registered trademarks of Terex Corporation or its subsidiaries.



GENIE® GS™ SLAB SCISSOR LIFTS

Genie® slab scissor lifts come standard with fully-sealed AC drive motors and dual-zone capabilities, making these lifts ideal for work at height indoors and outdoors, including data centres, warehouses, retail facilities, or commercial construction. With a wide range of height and width options, Genie's range of slab scissor lifts can fit the needs of virtually any job. Maintenance-free drive motors and right-sized, quality components reduce maintenance costs, lowering the total cost of ownership for slab scissor owners.

**ULTRA-
EFFICIENT**

**AC DRIVE
MOTORS**

**DURABLE
DESIGN**

**HIGH
RELIABILITY**

**LOW
TCO**

**REDUCED
MAINTENANCE
COSTS**

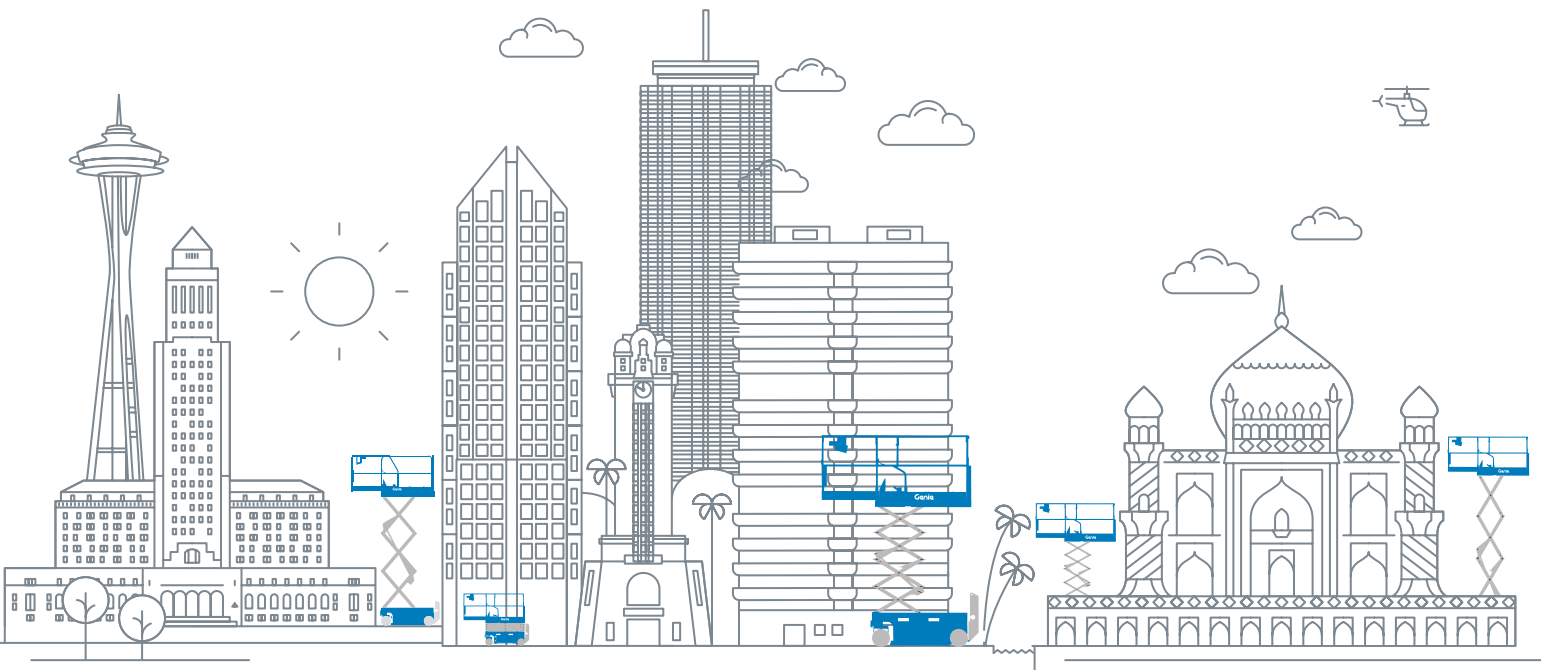



Specifications

GS™ Slab Scissor Lifts

MODEL	MAX. PLATFORM HEIGHT	LIFT CAPACITY	WIDTH*	TRANSPORT LENGTH*	WEIGHT*
Electric E-Drive Scissor Lifts					
GS™-1432m	14 ft 1 in	500 lb	2 ft 8 in	4 ft 7 in	1,985 lb
GS-1932m	18 ft 3 in	500 lb	2 ft 8 in	4 ft 7 in	2,600 lb
GS-1930	19 ft 3 in	500 lb	2 ft 6.2 in	6 ft	3,209 lb
GS-1932	19 ft 3 in	500 lb	2 ft 8.2 in	6 ft	2,929 lb
GS-2632	26 ft 1 in	500 lb	2 ft 8.2 in	8 ft	4,729 lb
GS-3232	32 ft 1 in	500 lb	2 ft 8.2 in	8 ft	5,367 lb
GS-2646	26 ft 1 in	1,000 lb	3 ft 10 in	8 ft	4,346 lb
GS-3246	32 ft 1 in	700 lb	3 ft 10 in	8 ft	5,218 lb
GS-4046	39 ft	770 lb	3 ft 10 in	8 ft 2 in	6,871 lb
GS-4655	45 ft 9 in	770 lb	4 ft 7 in	10 ft 2 in	8,160 lb

* With standard configuration. Will vary depending on options and/or country standards.

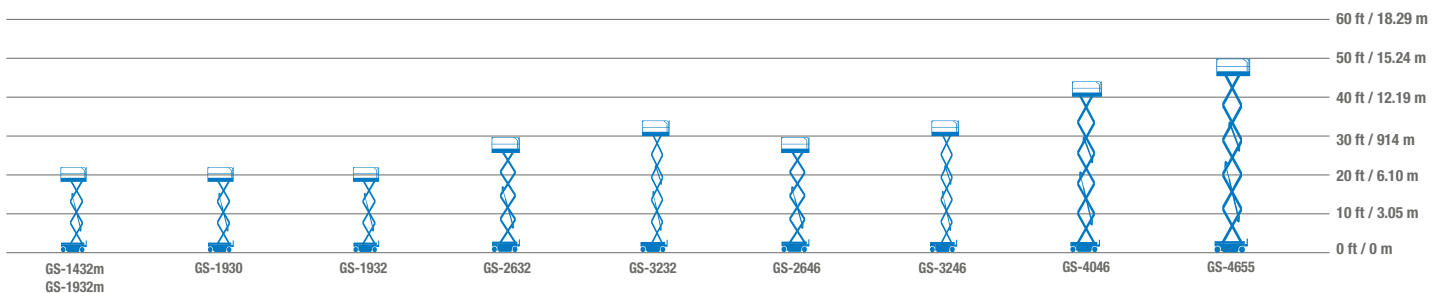

Genie® GS™ -1432m & GS-1932m

Specifications

Models	GS-1432m		GS-1932m	
	US	Metric	US	Metric
Measurements				
Working height max. - indoor ⁽¹⁾	20 ft 1 in	6.30 m	24 ft 2 in	7.55 m
Working height max. - outdoor ⁽¹⁾	18 ft	5.66 m	21 ft	6.57 m
A Platform height max. - indoor	14 ft 1 in	4.30 m	18 ft 3 in	5.55 m
A Platform height max. - outdoor	12 ft	3.66 m	15 ft	4.57 m
B Platform height - stowed	2 ft 6 in	0.77 m	2 ft 10 in	0.87 m
C Platform length - outside	4 ft 7 in	1.40 m	4 ft 7 in	1.40 m
C Platform length - outside, extended	6 ft 7 in	2.00 m	6 ft 7 in	2.00 m
Slide-out platform extension deck - length	2 ft	0.60 m	2 ft	0.60 m
D Platform width - outside	2 ft 6.5 in	0.78 m	2 ft 6.5 in	0.78 m
Guardrail height	3 ft 7 in	1.10 m	3 ft 7 in	1.10 m
Toeboard height	6 in	15 cm	6 in	15 cm
E Machine Height - stowed (fixed rails)	6 ft 2 in	1.88 m	6 ft 5 in	1.97 m
F Length machine - stowed	4 ft 7 in	1.40 m	4 ft 7 in	1.40 m
F Length machine - stowed, extended	6 ft 7 in	2.00 m	6 ft 7 in	2.00 m
G Width	32 in	0.81 m	32 in	0.81 m
H Wheelbase	3 ft 8 in	1.12 m	3 ft 8 in	1.12 m
I Ground clearance (center) - pothole guards retracted	2.8 in	7 cm	2.8 in	7 cm
I Ground clearance - pothole guards deployed	0.75 in	1.90 cm	0.75 in	1.90 cm

Productivity

Max. platform occupancy (in/out)	2/1		2/1	
Lift capacity	500 lb	227 kg	500 lb	227 kg
Lift capacity - extension deck extended	250 lb	113 kg	250 lb	113 kg
Max. platform drive height	14 ft 1 in	4.30 m	18 ft 2 in	5.55 m
Drive speed - stowed	2.5 mph	4.0 km/h	2.5 mph	4.0 km/h
Drive speed - raised	0.5 mph	0.8 km/h	0.5 mph	0.8 km/h
Gradeability - stowed ⁽²⁾	25%/14°		25%/14°	
Turning radius - inside/outside	0/4 ft 6 in	0/1.37 m	0/4 ft 6 in	0/1.37 m
Lifting speed - raise/lower	19/20 sec		26/20 sec	
Tilt sensor activation (front to back/side to side)	3°/1.5°		3°/1.5°	
Tires - solid non-marking	10×3 in	25.4×7.62 cm	10×3 in	25.4×7.62 cm

Power

Power	24V DC (2×12V 115Ah)	24V DC (2×12V 115Ah)
Hydraulic tank capacity (E-Drive)	1.5 gal	5.7L

Weight⁽³⁾ and Floor Loading⁽⁴⁾

Weight	1,985 lb	900 kg	2,600 lb	1,179 kg
Weight max. (adding all possible options)	2,064 lb	936 kg	2,680 lb	1,216 kg
Tire load max.	937 lb	425 kg	1257 lb	570 kg
Tire contact pressure	143 psi	988 kPa	164 psi	1,133 kPa
Occupied floor pressure	203 psf	9.73 kPa	254 psf	12.14 kPa

Sound and Vibration Levels

Sound Pressure level (ground workstation)	< 70 dBA		< 70 dBA	
Sound Pressure level (platform workstation)	< 70 dBA		< 70 dBA	
Vibrations	< 8 ft 2 in/s ²	< 2.5 m/s ²	< 8 ft 2 in/s ²	< 2.5 m/s ²

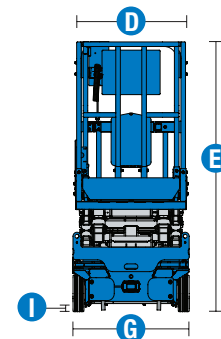
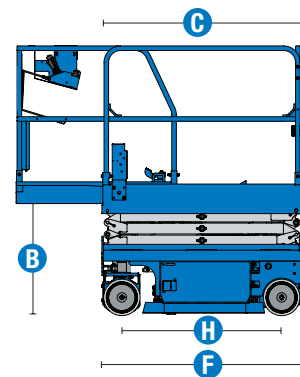
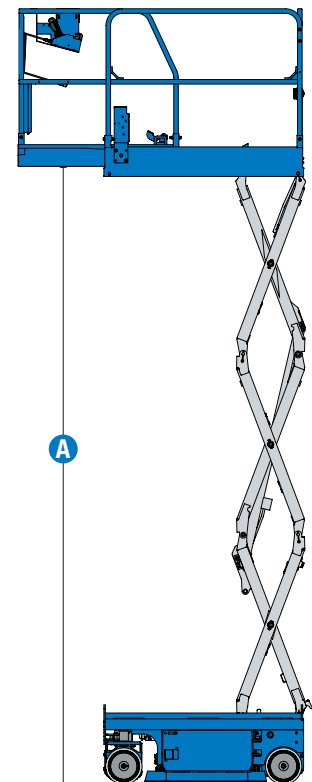

(1) The metric equivalent of working height adds 2 m to platform height. US adds 6 ft to platform height.

(2) Gradeability applies to driving on slopes and may vary depending on options and machine configurations. See operator's manual for details regarding slope ratings.

(3) Weight refers to standard configuration and may vary depending on options and/or country standards.

(4) Floor loading information is approximate and may vary depending on options and machine configurations. It should be used only with adequate safety factors.

Genie® GS™ -1432m & GS-1932m

SKU: Standard Model

- **GS1432M1AE0001:** GS-1432m, E-Drive

SKU: Standard Model

- **GS1932M1AE0001:** GS-1932m, E-Drive

* Build to Order

Option availability		S	S+	BtO
Power	Standard FLA flooded lead acid batteries	✓	✓	✓
	AGM Maintenance-free batteries		○	○
	Drive cut-out while charging		○	○
	Power Inverter		○	○
	Rear recessed charger receptacle	✓	✓	✓
Platform	Xtra Height (XH) Full Height Outdoor (GS-1932m)	✓	✓	✓
	Fixed rails, Half-height swing gate	✓	✓	✓
	Slide out extension deck	✓	✓	✓
	Air line to platform			○
	Automotive-style horn		○	○
	AC power to platform	✓	✓	✓
	Descent, tilt and motion alarm	✓	✓	✓
	Diamond plate platform deck	✓	✓	✓
	Dual LED flashing beacons	✓	✓	✓
	Electric horn	✓	✓	✓
	Lanyard attachment points	✓	✓	✓
	Platform control guard (PCON)	✓	✓	✓
	Platform load sense system	✓	✓	✓
	Proportional drive and lift	✓	✓	✓
	SmartLink dual zone control system	✓	✓	✓
Chassis	Lift Connect Telematics		○	○
	Lift Connect with Access Manager upgrade		○	○
	Lift Guard White Noise Alarm		○	○
	Lift Tools Spill Guard (E-Drive)		○	○
	Auxiliary platform lowering	✓	✓	✓
	Driveable at full height	✓	✓	✓
	Dual front wheel electric brakes	✓	✓	✓
	Dual front wheel sealed AC electric drive motors (E-Drive)	✓	✓	✓
	Electric brake release (E-Drive)	✓	✓	✓
	On board diagnostic system with battery charge indicator	✓	✓	✓
	Pothole protection	✓	✓	✓
	Rear fork pockets	✓	✓	✓
	Solid non-marking tires	✓	✓	✓
Tech Pro Link connector	✓	✓	✓	
Tie-down and lifting points	✓	✓	✓	

- S Standard
- S+ Standard +
- BtO Build to Order
- ✓ Standard Features
- Options



Compact Footprint



Lightweight



E-Drive



Genie Genuine Accessories⁽¹⁾

- Lift Tools Productivity Tools
- Lift Connect Telematics
- Tech Pro Link Handheld Device

(1) More accessories available from Genie Genuine Parts.

Product specifications are subject to change without notice or obligation. Photographs and/or drawings herein are for illustrative purposes only. Refer to the appropriate Operator's Manual for instructions on proper equipment use. Failure to follow instructions in the Operator's Manual may result in serious injury or death. The only warranty applicable to our equipment is the standard written warranty applicable to the particular product and sale and we make no other warranty, express or implied. Products and services listed may be trademarks, service marks or trade names of Terex Corporation and/or their subsidiaries in the USA and many other countries. Terex, Genie, Quality By Design, Xtra Capacity, Lift Power, Lift Guard, Lift Tools, Lift Connect and Tech Pro Link are registered trademarks of Terex Corporation or its subsidiaries.

Genie® GS™ -1930 & GS-1932

Specifications

Models	GS-1930		GS-1932	
Measurements	US	Metric	US	Metric
Working height max. - indoor ⁽¹⁾	25 ft 3 in	7.85 m	25 ft 3 in	7.85 m
Working height max. - outdoor ⁽¹⁾	20 ft 8 in	6.47 m	20 ft 8 in	6.47 m
A Platform height max. - indoor	19 ft 3 in	5.85 m	19 ft 3 in	5.85 m
A Platform height max. - outdoor	14 ft 8 in	4.47 m	14 ft 8 in	4.47 m
B Platform height - stowed	3 ft 5 in	1.04 m	3 ft 5 in	1.04 m
C Platform length - outside	5 ft 5 in	1.64 m	5 ft 5 in	1.66 m
C Platform length - outside, extended	8 ft 5 in	2.55 m	8 ft 5 in	2.55 m
Slide-out platform extension deck - length	2 ft 11.8 in	0.91 m	3 ft	0.91 m
D Platform width - outside	2 ft 5.9 in	0.76 m	29.9 in	0.76 m
Guardrail height	3 ft 7 in	1.10 m	3 ft 7 in	1.10 m
Toeboard height	6 in	15 cm	6 in	15 cm
E Machine Height - stowed (folding rails)	7 ft 1 in	2.16 m	7 ft 1 in	2.16 m
Machine Height - stowed (rails lowered)	5 ft 11 in	1.80 m	5 ft 11 in	1.80 m
F Length machine - stowed	6 ft	1.83 m	6 ft	1.83 m
F Length machine - stowed, extended	8 ft 11 in	2.73 m	8 ft 11 in	2.72 m
G Width	2 ft 6.2 in	0.77 m	32.2 in	0.82 m
H Wheelbase	4 ft 4 in	1.32 m	4 ft 4 in	1.32 m
I Ground clearance (center) - pothole guards retracted	3.2 in	8 cm	3.2 in	8 cm
I Ground clearance - pothole guards deployed	0.9 in	2.30 cm	0.9 in	2.30 cm

Productivity

Max. platform occupancy (in/out)	2/1		2/1	
Lift capacity	500 lb	227 kg	500 lb	227 kg
Lift capacity - extension deck extended	250 lb	113 kg	250 lb	113 kg
Max. platform drive height	19 ft 3 in	5.85 m	19 ft 3 in	5.85 m
Drive speed - stowed	2.5 mph	4.0 km/h	2.5 mph	4.0 km/h
Drive speed - raised	0.5 mph	0.8 km/h	0.5 mph	0.8 km/h
Gradeability - stowed ⁽²⁾	25%		25%	
Turning radius - inside/outside	0/5 ft 1 in	0/1.55 m	0/5 ft 1 in	0/1.55 m
Lifting speed - raise/lower	26/22 sec		26/22 sec	
Tilt sensor activation (front to back/side to side)	3°/1.5°		3°/1.5°	
Tires - solid non-marking	12×4.5 in	31×11 cm	12×4.5 in	30.5×11.5 cm

Power

Power - FLA	24V DC (4×6V 210Ah)		24V DC (4×6V 210Ah)	
Power - Lithium-Ion	24V DC (1×24V 90Ah)		24V DC (1×24V 90Ah)	
Hydraulic tank capacity (E-Drive)	1 gal	3.8L	1 gal	3.8L

Weight⁽³⁾ and Floor Loading⁽⁴⁾

Weight	3,209 lb	1,456 kg	2,929 lb	1,329 kg
Weight max. (adding all possible options)	3,354 lb	1,521 kg	3,205 lb	1,454 kg
Tire load max.	1,483 lb	672 kg	1,473 lb	668 kg
Tire contact pressure	165 psi	1,136 kPa	164 psi	1,128 kPa
Occupied floor pressure	287 psf	13.73 kPa	258 psf	12.38 kPa

Sound and Vibration Levels

Sound Pressure level (ground workstation)	< 70 dBA		< 70 dBA	
Sound Pressure level (platform workstation)	< 70 dBA		< 70 dBA	
Vibrations	< 8 ft 2 in/s ²	< 2.5 m/s ²	< 8 ft 2 in/s ²	< 2.5 m/s ²

(1) The metric equivalent of working height adds 2m to platform height. US adds 6ft to platform height.

(2) Gradeability applies to driving on slopes and may vary depending on options and machine configurations. See operator's manual for details regarding slope ratings.

(3) Weight refers to standard configuration and may vary depending on options and/or country standards.

(4) Floor loading information is approximate and may vary depending on options and machine configurations. It should be used only with adequate safety factors.

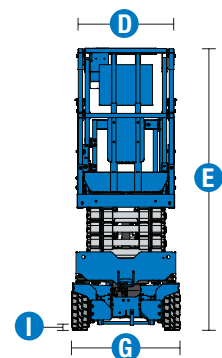
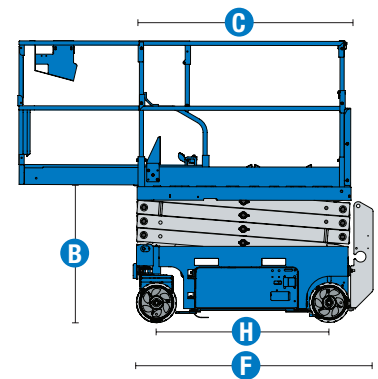
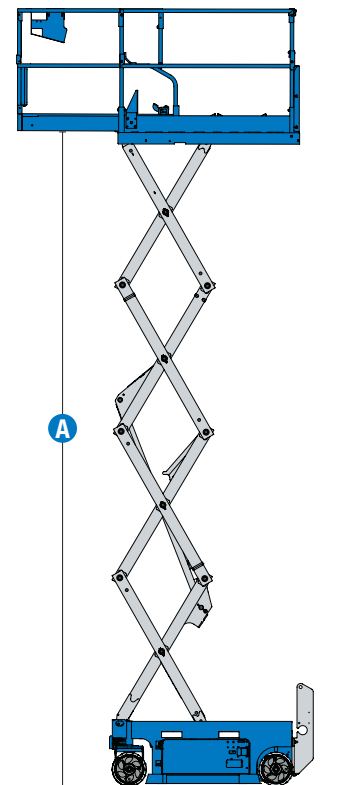

Genie® GS™ -1930 & GS-1932

SKU: Standard Model

- GS-1930, E-Drive*

* Build to Order

SKU: Standard Model

- **GS1932E1AE0002:** GS-1932, E-Drive

Option availability		S	S+	BtO
Power	Standard FLA flooded lead acid batteries	✓	✓	✓
	AGM Maintenance-free batteries		○	○
	Lithium-Ion battery			○
	Drive cut-out while charging		○	○
	Power Inverter		○	○
	Rear recessed charger receptacle	✓	✓	✓
Platform	Xtra Height (XH) Full Height Outdoor (GS-1932)	✓	✓	✓
	Folding rails, Half-height swing gate	✓	✓	✓
	Slide out extension deck	✓	✓	✓
	Air line to platform			○
	Automotive-style horn		○	○
	AC power to platform	✓	✓	✓
	Descent, tilt and motion alarm	✓	✓	✓
	Diamond plate platform deck	✓	✓	✓
	Dual LED flashing beacons	✓	✓	✓
	Electric horn	✓	✓	✓
	Lanyard attachment points	✓	✓	✓
	Platform control guard (PCON)	✓	✓	✓
	Platform load sense system	✓	✓	✓
	Proportional drive and lift	✓	✓	✓
	SmartLink dual zone control system	✓	✓	✓
Chassis	Lift Connect Telematics		○	○
	Lift Connect with Access Manager upgrade		○	○
	Biodegradable hydraulic oil			○
	EE Certification (Hydraulic drive)			○
	Lift Guard White Noise Alarm		○	○
	Lift Tools Spill Guard (E-Drive)			○
	Auxiliary platform lowering	✓	✓	✓
	Driveable at full height	✓	✓	✓
	Dual front wheel sealed AC electric drive motors (E-Drive)	✓	✓	✓
	Electric brake release (E-Drive)	✓	✓	✓
	On board diagnostic system with battery charge indicator	✓	✓	✓
	Pothole protection	✓	✓	✓
	Side and rear fork pockets	✓	✓	✓
	Solid non-marking tires	✓	✓	✓
Tech Pro Link connector	✓	✓	✓	
Tie-down and lifting points	✓	✓	✓	

- S Standard
- S+ Standard +
- BtO Build to Order
- ✓ Standard Features
- Options



Indoor & Outdoor Use



Side Forklift Pockets



Optional E-Drive

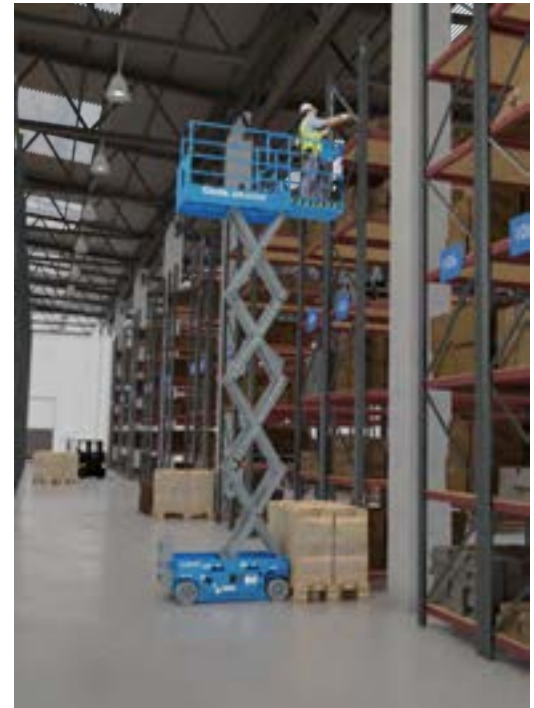

Genie Genuine Accessories⁽¹⁾

- Lift Tools Productivity Tools
- Lift Connect Telematics
- Tech Pro Link Handheld Device

(1) More accessories available from Genie Genuine Parts.

Product specifications are subject to change without notice or obligation. Photographs and/or drawings herein are for illustrative purposes only. Refer to the appropriate Operator's Manual for instructions on proper equipment use. Failure to follow instructions in the Operator's Manual may result in serious injury or death. The only warranty applicable to our equipment is the standard written warranty applicable to the particular product and sale and we make no other warranty, express or implied. Products and services listed may be trademarks, service marks or trade names of Terex Corporation and/or their subsidiaries in the USA and many other countries. Terex, Genie, Quality By Design, Xtra Capacity, Lift Power, Lift Guard, Lift Tools, Lift Connect and Tech Pro Link are registered trademarks of Terex Corporation or its subsidiaries.

Genie® GS™ -2632 & GS-2646

Specifications

Models	GS-2632		GS-2646	
Measurements	US	Metric	US	Metric
Working height max. - indoor ⁽¹⁾	32 ft 1 in	9.96 m	32 ft 1 in	9.96 m
Working height max. - outdoor ⁽¹⁾	25 ft	7.79 m	25 ft 8 in	7.99 m
A Platform height max. - indoor	26 ft 1 in	7.96 m	26 ft 1 in	7.96 m
A Platform height max. - outdoor	19 ft	5.79 m	19 ft 8 in	5.99 m
B Platform height - stowed	3 ft 11 in	1.19 m	3 ft 11 in	1.19 m
C Platform length - outside	7 ft 5 in	2.26 m	7 ft 5 in	2.26 m
C Platform length - outside, extended	10 ft 5 in	3.18 m	10 ft 5 in	3.18 m
Slide-out platform extension deck - length	3 ft	0.91 m	3 ft	0.91 m
D Platform width - outside	32.9 in	0.84 m	3 ft 10 in	1.18 m
Guardrail height	3 ft 7 in	1.10 m	3 ft 7 in	1.10 m
Toeboard height	6 in	15 cm	6 in	15 cm
E Machine Height - stowed (folding rails)	7 ft 7 in	2.31 m	7 ft 7 in	2.31 m
Machine Height - stowed (rails lowered)	6 ft 4 in	1.94 m	5 ft 7 in	1.70 m
F Length machine - stowed	8 ft	2.44 m	8 ft	2.44 m
F Length machine - stowed, extended	10 ft 11 in	3.33 m	10 ft 11 in	3.33 m
G Width	32.2 in	0.82 m	3 ft 10 in	1.18 m
H Wheelbase	6 ft 1 in	1.85 m	6 ft 1 in	1.85 m
I Ground clearance (center) - pothole guards retracted	5 in	12 cm	5 in	12 cm
I Ground clearance - pothole guards deployed	0.9 in	2.30 cm	0.9 in	2.30 cm

Productivity

Max. platform occupancy (in/out)	2/1		2/1	
Lift capacity	500 lb	227 kg	1,000 lb	454 kg
Lift capacity - extension deck extended	250 lb	113 kg	250 lb	113 kg
Max. platform drive height	26 ft 1 in	7.96 m	26 ft 1 in	7.96 m
Drive speed - stowed	2.0 mph	3.2 km/h	2.0 mph	3.2 km/h
Drive speed - raised	0.5 mph	0.8 km/h	0.5 mph	0.8 km/h
Gradeability - stowed ⁽²⁾	25%		25%	
Turning radius - inside/outside	0/7 ft	0/2.13 m	0/7 ft 6 in	0/2.29 m
Lifting speed - raise/lower	43/33 sec		41/30 sec	
Tilt sensor activation (front to back/side to side)	3°/1.5°		3°/1.5°	
Tires - solid non-marking	15×5 in	38×13 cm	15×5 in	38×13 cm

Power

Power - FLA	24V DC (4×6V 210Ah)	24V DC (4×6V 210Ah)
Power - Lithium-Ion	24V DC (1×24V 90Ah)	24V DC (1×24V 90Ah)
Hydraulic tank capacity (E-Drive)	4 gal	15L

Weight⁽³⁾ and Floor Loading⁽⁴⁾

Weight	4,729 lb	2,145 kg	4,346 lb	1,971 kg
Weight max. (adding all possible options)	4,900 lb	2,223 kg	4,542 lb	2,060 kg
Tire load max.	1,820 lb	826 kg	2,127 lb	965 kg
Tire contact pressure	119 psi	824 kPa	124.6 psi	935 kPa
Occupied floor pressure	270 psf	12.91 kPa	192 psf	9.83 kPa

Sound and Vibration Levels

Sound Pressure level (ground workstation)	< 70 dBA		< 70 dBA	
Sound Pressure level (platform workstation)	< 70 dBA		< 70 dBA	
Vibrations	< 8 ft 2 in/s ²	< 2.5 m/s ²	< 8 ft 2 in/s ²	< 2.5 m/s ²

(1) The metric equivalent of working height adds 2 m to platform height. US adds 6 ft to platform height.

(2) Gradeability applies to driving on slopes and may vary depending on options and machine configurations. See operator's manual for details regarding slope ratings.

(3) Weight refers to standard configuration and may vary depending on options and/or country standards.

(4) Floor loading information is approximate and may vary depending on options and machine configurations. It should be used only with adequate safety factors.

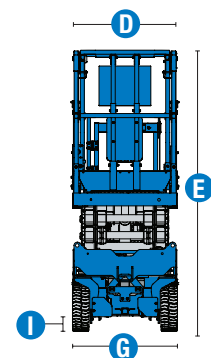
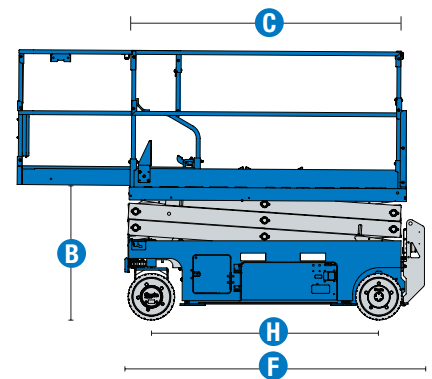
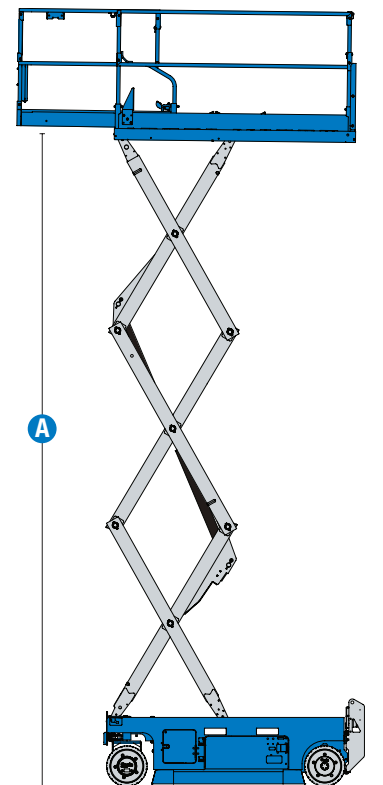

Genie® GS™ -2632 & GS-2646

SKU: Standard Model

- **GS2632E1AE0003:** GS-2632, E-Drive

* Build to Order

SKU: Standard Model

- **GS264601AE0003:** GS-2646, E-Drive

Option availability		S	S+	BtO
Power	Standard FLA flooded lead acid batteries	✓	✓	✓
	AGM Maintenance-free batteries		○	○
	Lithium-Ion battery			○
	Drive cut-out while charging		○	○
	Power Inverter		○	○
	Rear recessed charger receptacle	✓	✓	✓
	Folding rails, Full-height swing gate (GS-2646)	✓	✓	✓
Platform	Folding rails, Half-height swing gate (GS-2632)	✓	✓	✓
	Slide out extension deck	✓	✓	✓
	Air line to platform			○
	Automotive-style horn		○	○
	AC power to platform	✓	✓	✓
	Descent, tilt and motion alarm	✓	✓	✓
	Diamond plate platform deck	✓	✓	✓
	Dual LED flashing beacons	✓	✓	✓
	Electric horn	✓	✓	✓
	Lanyard attachment points	✓	✓	✓
	Platform control guard (PCON)	✓	✓	✓
	Platform load sense system	✓	✓	✓
	Proportional drive and lift	✓	✓	✓
	SmartLink dual zone control system	✓	✓	✓
	Chassis	Lift Connect Telematics		○
Lift Connect with Access Manager upgrade			○	○
Biodegradable hydraulic oil				○
EE Certification (Hydraulic drive)				○
Lift Guard White Noise Alarm			○	○
Lift Tools Spill Guard (E-Drive)				○
Auxiliary platform lowering		✓	✓	✓
Driveable at full height		✓	✓	✓
Dual front wheel sealed AC electric drive motors (E-Drive)		✓	✓	✓
Electric brake release (E-Drive)		✓	✓	✓
On board diagnostic system with battery charge indicator		✓	✓	✓
Pothole protection		✓	✓	✓
Side and rear fork pockets		✓	✓	✓
Solid non-marking tires		✓	✓	✓
Tech Pro Link connector		✓	✓	✓
Tie-down and lifting points	✓	✓	✓	

- S Standard
- S+ Standard +
- BtO Build to Order
- ✓ Standard Features
- Options



Indoor & Outdoor Use



Side Forklift Pockets



Optional E-Drive



Genie Genuine Accessories⁽¹⁾

- Lift Tools Productivity Tools
- Lift Connect Telematics
- Tech Pro Link Handheld Device

(1) More accessories available from Genie Genuine Parts.

Product specifications are subject to change without notice or obligation. Photographs and/or drawings herein are for illustrative purposes only. Refer to the appropriate Operator's Manual for instructions on proper equipment use. Failure to follow instructions in the Operator's Manual may result in serious injury or death. The only warranty applicable to our equipment is the standard written warranty applicable to the particular product and sale and we make no other warranty, express or implied. Products and services listed may be trademarks, service marks or trade names of Terex Corporation and/or their subsidiaries in the USA and many other countries. Terex, Genie, Quality By Design, Xtra Capacity, Lift Power, Lift Guard, Lift Tools, Lift Connect and Tech Pro Link are registered trademarks of Terex Corporation or its subsidiaries.

Genie® GS™ -3232 & GS-3246

Specifications

Models	GS-3232		GS-3246	
Measurements	US	Metric	US	Metric
Working height max. - indoor ⁽¹⁾	38 ft 1 in	11.78 m	38 ft 1 in	11.78 m
Working height max. - outdoor ⁽¹⁾	24 ft	7.49 m	28 ft	8.71 m
A Platform height max. - indoor	32 ft 1 in	9.78 m	32 ft 1 in	9.78 m
A Platform height max. - outdoor	18 ft	5.49 m	22 ft	6.71 m
B Platform height - stowed	4 ft 4 in	1.32 m	4 ft 4 in	1.32 m
C Platform length - outside	7 ft 5 in	2.26 m	7 ft 5 in	2.26 m
C Platform length - outside, extended	10 ft 5 in	3.18 m	10 ft 5 in	3.18 m
Slide-out platform extension deck - length	3 ft	0.91 m	3 ft	0.91 m
D Platform width - outside	32.9 in	0.84 m	3 ft 10 in	1.18 m
Guardrail height	3 ft 7 in	1.10 m	3 ft 7 in	1.10 m
Toeboard height	6 in	15 cm	6 in	15 cm
E Machine Height - stowed (folding rails)	8 ft	2.44 m	8 ft	2.44 m
Machine Height - stowed (rails lowered)	6 ft 10 in	2.08 m	6 ft	1.83 m
F Length machine - stowed	8 ft	2.44 m	8 ft	2.44 m
F Length machine - stowed, extended	10 ft 11 in	3.33 m	10 ft 11 in	3.33 m
G Width	32.2 in	0.82 m	3 ft 10 in	1.18 m
H Wheelbase	6 ft 1 in	1.85 m	6 ft 1 in	1.85 m
I Ground clearance (center) - pothole guards retracted	5 in	12 cm	5 in	12 cm
I Ground clearance - pothole guards deployed	0.9 in	2.30 cm	0.9 in	2.30 cm

Productivity

Max. platform occupancy (in/out)	2/1		2/1	
Lift capacity	500 lb	227 kg	700 lb	318 kg
Lift capacity - extension deck extended	250 lb	113 kg	250 lb	113 kg
Max. platform drive height	20 ft	6.71 m	32 ft 1 in	9.78 m
Drive speed - stowed	2.0 mph	3.2 km/h	2.0 mph	3.2 km/h
Drive speed - raised	0.5 mph	0.8 km/h	0.5 mph	0.8 km/h
Gradeability - stowed ⁽²⁾	25%		25%	
Turning radius - inside/outside	0/7 ft	0/2.13 m	0/7 ft 6 in	0/2.29 m
Lifting speed - raise/lower	58/32 sec		53/34 sec	
Tilt sensor activation (front to back/side to side)	3° / 1.5°		3° / 1.5°	
Max. outrigger leveling (front to back/side to side)	2° / 5°		-	
Tires - solid non-marking	15x5 in	38x13 cm	15x5 in	38x13 cm

Power

Power - FLA	24V DC (4x6V 210Ah)	24V DC (4x6V 210Ah)
Power - Lithium-Ion	24V DC (1x24V 90Ah)	24V DC (1x24V 90Ah)
Hydraulic tank capacity (E-Drive)	4 gal	15 L

Weight⁽³⁾ and Floor Loading⁽⁴⁾

Weight	5,367 lb	2,434 kg	5,218 lb	2,367 kg
Weight max. (adding all possible options)	5,537 lb	2,512 kg	5,379 lb	2,440 kg
Tire load max.	1,909 lb	866 kg	2,227 lb	1,010 kg
Tire contact pressure	125 psi	864 kPa	146 psi	1,021 kPa
Occupied floor pressure	307 psf	14.72 kPa	210 psf	10.23 kPa

Sound and Vibration Levels

Sound Pressure level (ground workstation)	< 70 dBA	< 70 dBA
Sound Pressure level (platform workstation)	< 70 dBA	< 70 dBA
Vibrations	< 8 ft 2 in/s ²	< 2.5 m/s ²

(1) The metric equivalent of working height adds 2 m to platform height. US adds 6 ft to platform height.

(2) Gradeability applies to driving on slopes and may vary depending on options and machine configurations. See operator's manual for details regarding slope ratings.

(3) Weight refers to standard configuration and may vary depending on options and/or country standards.

(4) Floor loading information is approximate and may vary depending on options and machine configurations. It should be used only with adequate safety factors.

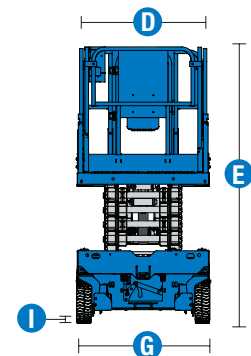
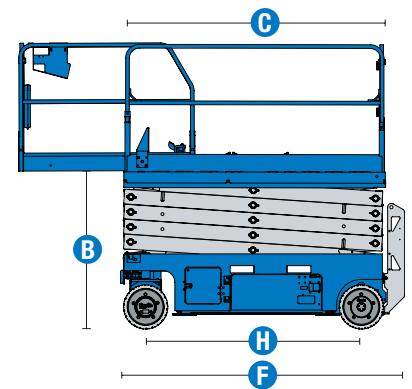
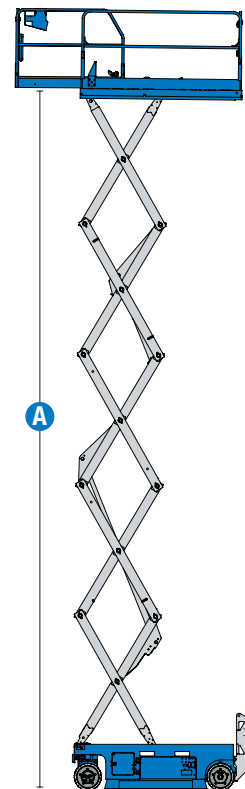

Genie® GS™ -3232 & GS-3246

SKU: Standard Model

- **GS323201AE0004:** GS-3232, E-Drive

* Build to Order

SKU: Standard Model

- **GS324601AE0002:** GS-3246, E-Drive

Option availability		S	S+	BtO
Power	Standard FLA flooded lead acid batteries	✓	✓	✓
	AGM Maintenance-free batteries		○	○
	Lithium-Ion battery			○
	Drive cut-out while charging		○	○
	Power Inverter		○	○
	Rear recessed charger receptacle	✓	✓	✓
Platform	Folding rails, Full-height swing gate (GS-3246)	✓	✓	✓
	Folding rails, Half-height swing gate (GS-3232)	✓	✓	✓
	Slide out extension deck	✓	✓	✓
	Air line to platform			○
	Automotive-style horn		○	○
	AC power to platform	✓	✓	✓
	Descent, tilt and motion alarm	✓	✓	✓
	Diamond plate platform deck	✓	✓	✓
	Dual LED flashing beacons	✓	✓	✓
	Electric horn	✓	✓	✓
	Lanyard attachment points	✓	✓	✓
	Platform control guard (PCON)	✓	✓	✓
	Platform load sense system	✓	✓	✓
	Proportional drive and lift	✓	✓	✓
	SmartLink dual zone control system	✓	✓	✓
Chassis	Lift Connect Telematics		○	○
	Lift Connect with Access Manager upgrade		○	○
	Biodegradable hydraulic oil			○
	Lift Guard White Noise Alarm		○	○
	Lift Tools Spill Guard (E-Drive)			○
	Auto leveling hydraulic outriggers (GS-3232)	✓	✓	✓
	Auxiliary platform lowering	✓	✓	✓
	Driveable at full height (GS-3246 only)	✓	✓	✓
	Dual front wheel sealed AC electric drive motors (E-Drive)	✓	✓	✓
	Electric brake release (E-Drive)	✓	✓	✓
	On board diagnostic system with battery charge indicator	✓	✓	✓
	Pothole protection	✓	✓	✓
	Side and rear fork pockets	✓	✓	✓
	Solid non-marking tires	✓	✓	✓
Tech Pro Link connector	✓	✓	✓	
Tie-down and lifting points	✓	✓	✓	

- S Standard
- S+ Standard +
- BtO Build to Order
- ✓ Standard Features
- Options



Indoor & Outdoor Use



Side Forklift Pockets



E-Drive



Genie Genuine Accessories⁽¹⁾

- Lift Tools Productivity Tools
- Lift Connect Telematics
- Tech Pro Link Handheld Device

(1) More accessories available from Genie Genuine Parts.

Product specifications are subject to change without notice or obligation. Photographs and/or drawings herein are for illustrative purposes only. Refer to the appropriate Operator's Manual for instructions on proper equipment use. Failure to follow instructions in the Operator's Manual may result in serious injury or death. The only warranty applicable to our equipment is the standard written warranty applicable to the particular product and sale and we make no other warranty, express or implied. Products and services listed may be trademarks, service marks or trade names of Terex Corporation and/or their subsidiaries in the USA and many other countries. Terex, Genie, Quality By Design, Xtra Capacity, Lift Power, Lift Guard, Lift Tools, Lift Connect and Tech Pro Link are registered trademarks of Terex Corporation or its subsidiaries.

Genie® GS™ -4046

Specifications

Models	GS-4046	
Measurements	US	Metric
Working height max. - indoor ⁽¹⁾	45ft	13.89m
Working height max. - outdoor ⁽¹⁾	29ft	9.01m
A Platform height max. - indoor	39ft	11.89m
A Platform height max. - outdoor	23ft	7.01m
B Platform height - stowed	4ft 9in	1.45m
C Platform length - outside	7ft 5in	2.26m
C Platform length - outside, extended	10ft 5in	3.18m
Slide-out platform extension deck - length	3ft	0.91m
D Platform width - outside	3ft 10in	1.18m
Guardrail height	3ft 7in	1.10m
Toeboard height	6in	15cm
E Machine Height - stowed (folding rails)	8ft 5in	2.57m
Machine Height - stowed (rails lowered)	6ft 6in	1.98m
F Length machine - stowed	8ft 2in	2.48m
F Length machine - stowed, extended	11ft 6in	3.51m
G Width	3ft 10in	1.18m
H Wheelbase	6ft 1in	1.85m
I Ground clearance (center) - pothole guards retracted	5in	12cm
I Ground clearance - pothole guards deployed	0.9in	2.30cm

Productivity

Max. platform occupancy (in/out)	3/1	
Lift capacity	770lb	350lb
Lift capacity - extension deck extended	250lb	113kg
Max. platform drive height	39ft 2in	11.94m
Drive speed - stowed	2.0mph	3.2km/h
Drive speed - raised	0.5mph	0.8km/h
Gradeability - stowed ⁽²⁾	25%	
Turning radius - inside/outside	0/7ft 6in	0/2.29m
Lifting speed - raise/lower	71/41 sec	
Tilt sensor activation (front to back/side to side)	3° / 1.5°	
Tires - solid non-marking	15x5in	38x13cm

Power

Power	24V DC (4x12V 300Ah)	
Hydraulic tank capacity (E-Drive)	4.9gal	18.5L

Weight⁽³⁾ and Floor Loading⁽⁴⁾

Weight	6,871lb	3,117kg
Weight max. (adding all possible options)	7,022lb	3,185kg
Tire load max.	2,735lb	1,241kg
Tire contact pressure	170.3psi	1,174kPa
Occupied floor pressure	275psf	13.17kPa

Sound and Vibration Levels

Sound Pressure level (ground workstation)	< 70 dBA	
Sound Pressure level (platform workstation)	< 70 dBA	
Vibrations	< 8ft 2in/s ²	< 2.5m/s ²

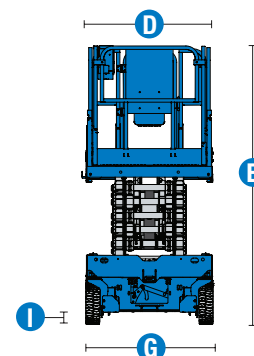
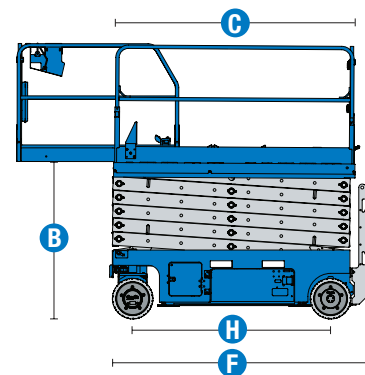
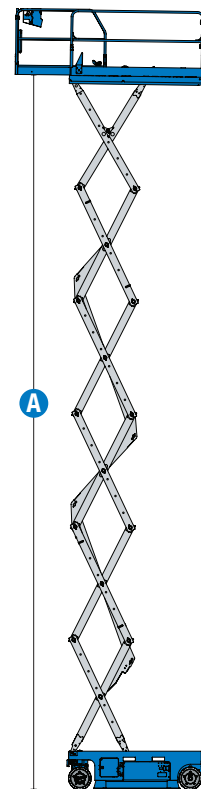

(1) The metric equivalent of working height adds 2m to platform height. US adds 6ft to platform height.

(2) Gradeability applies to driving on slopes and may vary depending on options and machine configurations. See operator's manual for details regarding slope ratings.

(3) Weight refers to standard configuration and may vary depending on options and/or country standards.

(4) Floor loading information is approximate and may vary depending on options and machine configurations. It should be used only with adequate safety factors.

Genie® GS™ -4046

SKU: Standard Model

- **GS4046E1AE0002:** GS-4046, E-Drive

* Build to Order

Option availability		S	S+	BtO
Power	Standard FLA flooded lead acid batteries	✓	✓	✓
	Drive cut-out while charging		○	○
	Power Inverter		○	○
	Rear recessed charger receptacle	✓	✓	✓
Platform	Folding rails, Full-height swing gate	✓	✓	✓
	Slide out extension deck	✓	✓	✓
	Air line to platform			○
	Automotive-style horn		○	○
	AC power to platform	✓	✓	✓
	Descent, tilt and motion alarm	✓	✓	✓
	Diamond plate platform deck	✓	✓	✓
	Dual LED flashing beacons	✓	✓	✓
	Electric horn	✓	✓	✓
	Lanyard attachment points	✓	✓	✓
	Platform control guard (PCON)	✓	✓	✓
	Platform load sense system	✓	✓	✓
	Proportional drive and lift	✓	✓	✓
	SmartLink dual zone control system	✓	✓	✓
Chassis	Lift Connect Telematics		○	○
	Lift Connect with Access Manager upgrade		○	○
	Lift Guard White Noise Alarm		○	○
	Lift Tools Spill Guard (E-Drive)			○
	Auxiliary platform lowering	✓	✓	✓
	Driveable at full height	✓	✓	✓
	Dual front wheel sealed AC electric drive motors (E-Drive)	✓	✓	✓
	Electric brake release (E-Drive)	✓	✓	✓
	On board diagnostic system with battery charge indicator	✓	✓	✓
	Pothole protection	✓	✓	✓
	Side and rear fork pockets	✓	✓	✓
	Solid non-marking tires	✓	✓	✓
	Tech Pro Link connector	✓	✓	✓
Tie-down and lifting points	✓	✓	✓	

- S Standard
- S+ Standard +
- BtO Build to Order
- ✓ Standard Features
- Options



Indoor & Outdoor Use



Side Forklift Pockets



E-Drive



Genie Genuine Accessories⁽¹⁾

- Lift Tools Productivity Tools
- Lift Connect Telematics
- Tech Pro Link Handheld Device

(1) More accessories available from Genie Genuine Parts.

Product specifications are subject to change without notice or obligation. Photographs and/or drawings herein are for illustrative purposes only. Refer to the appropriate Operator's Manual for instructions on proper equipment use. Failure to follow instructions in the Operator's Manual may result in serious injury or death. The only warranty applicable to our equipment is the standard written warranty applicable to the particular product and sale and we make no other warranty, express or implied. Products and services listed may be trademarks, service marks or trade names of Terex Corporation and/or their subsidiaries in the USA and many other countries. Terex, Genie, Quality By Design, Xtra Capacity, Lift Power, Lift Guard, Lift Tools, Lift Connect and Tech Pro Link are registered trademarks of Terex Corporation or its subsidiaries.



Genie® GS™ -4655

Specifications

Models	GS-4655	
Measurements	US	Metric
Working height max. - indoor ⁽¹⁾	51 ft 9 in	15.95 m
Working height max. - outdoor ⁽¹⁾	27 ft 6 in	8.55 m
A Platform height max. - indoor	45 ft 9 in	13.95 m
A Platform height max. - outdoor	21 ft 6 in	6.55 m
B Platform height - stowed	5 ft 5 in	1.64 m
C Platform length - outside	9 ft 4 in	2.84 m
C Platform length - outside, extended	13 ft 4 in	4.10 m
Slide-out platform extension deck - length	4 ft	1.22 m
D Platform width - outside	4 ft 5 in	1.35 m
Guardrail height	3 ft 7.3 in	1.10 m
Toeboard height	6 in	15 cm
E Machine Height - stowed (folding rails)	9 ft 1 in	2.77 m
Machine Height - stowed (rails lowered)	6 ft 6 in	1.98 m
F Length machine - stowed	10 ft 2 in	3.11 m
F Length machine - stowed, extended	14 ft 2 in	4.33 m
G Width	4 ft 7 in	1.40 m
H Wheelbase	8 ft 1 in	2.47 m
I Ground clearance (center) - pothole guards retracted	5.9 in	15 cm
I Ground clearance - pothole guards deployed	0.75 in	2 cm

Productivity

Max. platform occupancy (in/out)	3/2	
Lift capacity	770 lb	350 kg
Lift capacity - extension deck extended	300 lb	136 kg
Max. platform drive height	45 ft 9 in	13.95 m
Drive speed - stowed	2.5 mph	4.0 km/h
Drive speed - raised	0.5 mph	0.8 km/h
Gradeability - stowed ⁽²⁾	25%	
Turning radius - inside/outside	12 in/10 ft	31 cm/3.05 m
Lifting speed - raise/lower	92/58 sec	
Tilt sensor activation (front to back/side to side)	3° / 1.5°	
Tires - solid non-marking	15x5 in	38x13 cm

Power

Power	24V DC (4x12V 300Ah)	
Hydraulic tank capacity (E-Drive)	7.5 gal	28.4 L

Weight⁽³⁾ and Floor Loading⁽⁴⁾

Weight	8,160 lb	3,701 kg
Weight max. (adding all possible options)	8,160 lb	3,701 kg
Tire load max.	3,682 lb	1,670 kg
Tire contact pressure	210 psi	1,451 kPa
Occupied floor pressure	205 psf	9.81 kPa

Sound and Vibration Levels

Sound Pressure level (ground workstation)	< 70 dBA	
Sound Pressure level (platform workstation)	< 70 dBA	
Vibrations	< 8 ft 2 in/s ²	< 2.5 m/s ²

(1) The metric equivalent of working height adds 2m to platform height. US adds 6ft to platform height.

(2) Gradeability applies to driving on slopes and may vary depending on options and machine configurations. See operator's manual for details regarding slope ratings.

(3) Weight refers to standard configuration and may vary depending on options and/or country standards.

(4) Floor loading information is approximate and may vary depending on options and machine configurations. It should be used only with adequate safety factors.

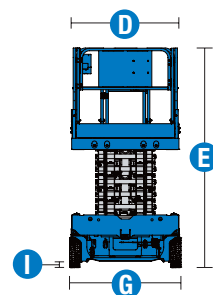
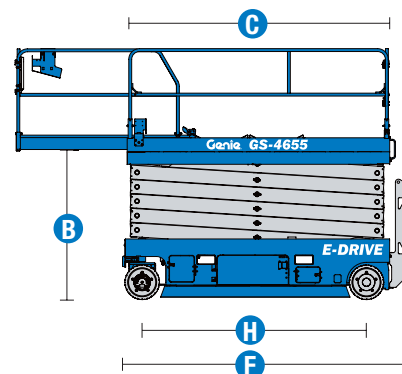
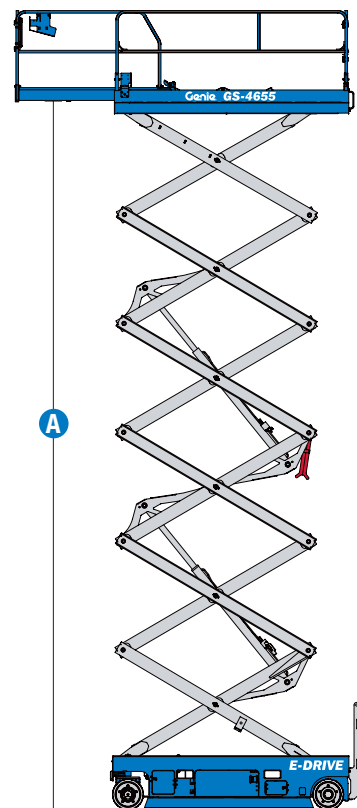

Genie® GS™ -4655

SKU: Standard Model

- **GS4655E1AE0002:** GS-4655, E-Drive

* Build to Order

Option availability		S	S+	BtO
Power	Standard FLA flooded lead acid batteries	✓	✓	✓
	AGM Maintenance-free batteries		○	○
	Drive cut-out while charging		○	○
	Power Inverter		○	○
	Rear recessed charger receptacle	✓	✓	✓
Platform	Folding rails, Full-height swing gate	✓	✓	✓
	Slide out extension deck	✓	✓	✓
	Air line to platform			○
	Automotive-style horn		○	○
	AC power to platform	✓	✓	✓
	Descent, tilt and motion alarm	✓	✓	✓
	Diamond plate platform deck	✓	✓	✓
	Dual LED flashing beacons	✓	✓	✓
	Electric horn	✓	✓	✓
	Lanyard attachment points	✓	✓	✓
	Platform control guard (PCON)	✓	✓	✓
	Platform load sense system	✓	✓	✓
	Proportional drive and lift	✓	✓	✓
	SmartLink dual zone control system	✓	✓	✓
Chassis	Lift Connect Telematics		○	○
	Lift Connect with Access Manager upgrade		○	○
	Lift Guard White Noise Alarm		○	○
	Auxiliary platform lowering	✓	✓	✓
	Driveable at full height	✓	✓	✓
	Dual front wheel sealed AC electric drive motors (E-Drive)	✓	✓	✓
	Electric brake release (E-Drive)	✓	✓	✓
	On board diagnostic system with battery charge indicator	✓	✓	✓
	Pothole protection	✓	✓	✓
	Side and rear fork pockets	✓	✓	✓
	Solid non-marking tires	✓	✓	✓
Tech Pro Link connector	✓	✓	✓	
Tie-down and lifting points	✓	✓	✓	

- S Standard
- S+ Standard +
- BtO Build to Order
- ✓ Standard Features
- Options



Indoor & Outdoor Use



Max. Lift Capacity



E-Drive

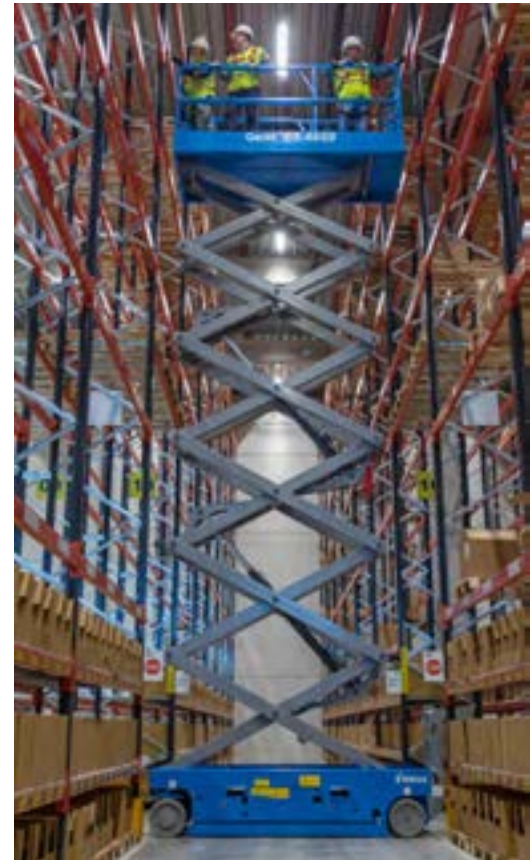

Genie Genuine Accessories⁽¹⁾

- Lift Tools Productivity Tools
- Lift Connect Telematics
- Tech Pro Link Handheld Device

(1) More accessories available from Genie Genuine Parts.

Product specifications are subject to change without notice or obligation. Photographs and/or drawings herein are for illustrative purposes only. Refer to the appropriate Operator's Manual for instructions on proper equipment use. Failure to follow instructions in the Operator's Manual may result in serious injury or death. The only warranty applicable to our equipment is the standard written warranty applicable to the particular product and sale and we make no other warranty, express or implied. Products and services listed may be trademarks, service marks or trade names of Terex Corporation and/or their subsidiaries in the USA and many other countries. Terex, Genie, Quality By Design, Xtra Capacity, Lift Power, Lift Guard, Lift Tools, Lift Connect and Tech Pro Link are registered trademarks of Terex Corporation or its subsidiaries.

GENIE® ROUGH TERRAIN SCISSOR LIFTS

Genie® rough terrain scissor lifts offer rugged performance on rough, unprepared outdoor construction sites. Built-in terrainability features such as positive traction control, active oscillating axles and outstanding gradeability allow them to navigate easily through uneven terrain.

With a standard multi-position slide-out extension deck and the ability to carry from 2 to 7 operators on board, they are ideal for jobs that require greater capacity for more workers, materials and tools.

TWO
POWER OPTIONS

EXCELLENT
TERRAINABILITY

EASY
SERVICE

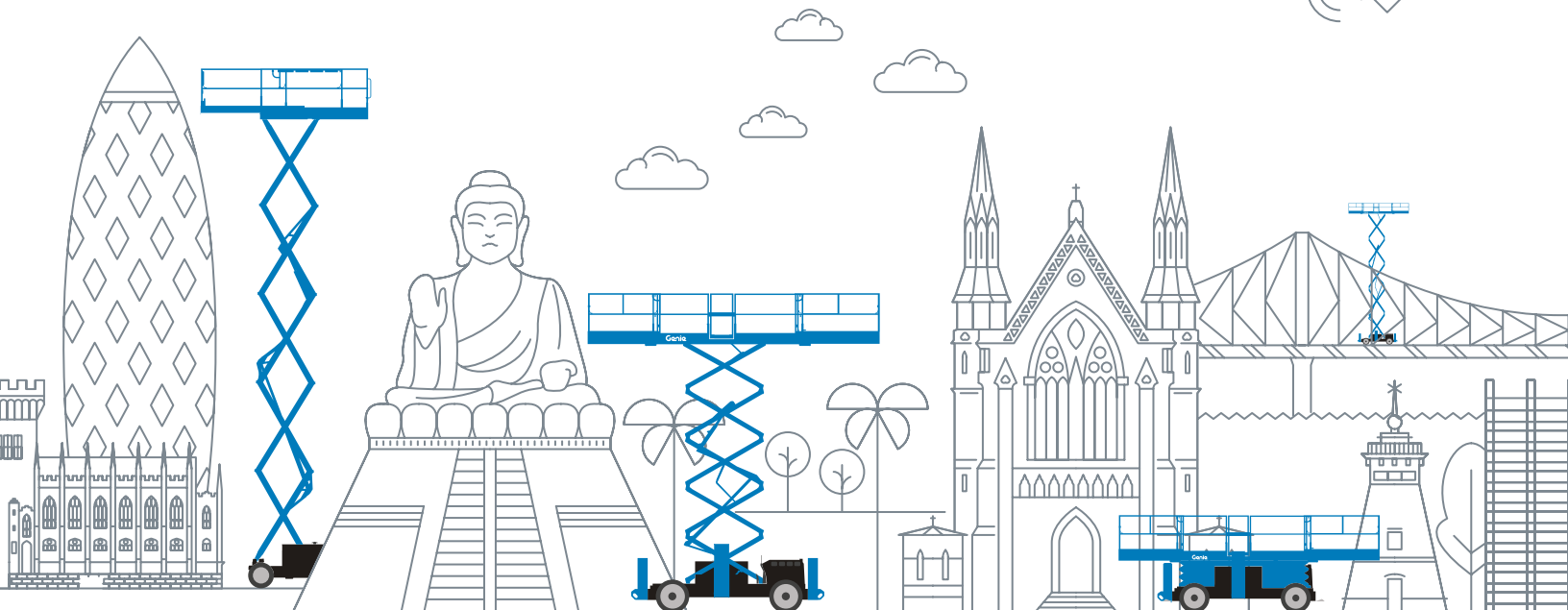



Specifications

Rough Terrain Scissor Lifts

MODEL	MAX. PLATFORM HEIGHT	LIFT CAPACITY	WIDTH*	TRANSPORT LENGTH*	WEIGHT*
Rough Terrain Scissor Lifts					
GS™-2669 DC & GS-2669 RT	26 ft 2 in	1,500 lb	5 ft 9 in	10 ft 3 in	7,149 lb/7,946 lb
GS-3369 DC & GS-3369 RT	32 ft 8 in	1,000 lb	5 ft 9 in	10 ft 3 in	7,599 lb/7,687 lb
GS-4069 DC & GS-4069 RT	40 ft 3 in	800 lb	5 ft 9 in	10 ft 3 in	10,392 lb/10,948 lb
GS-3390	33 ft	2,500 lb	7 ft 8 in	12 ft 11.25 in	11,977 lb
GS-4390	43 ft	1,500 lb	7 ft 8 in	12 ft 11.25 in	12,894 lb
GS-5390	53 ft	1,500 lb	7 ft 8 in	16 ft	16,567 lb

* With standard configuration. Will vary depending on options and/or country standards.

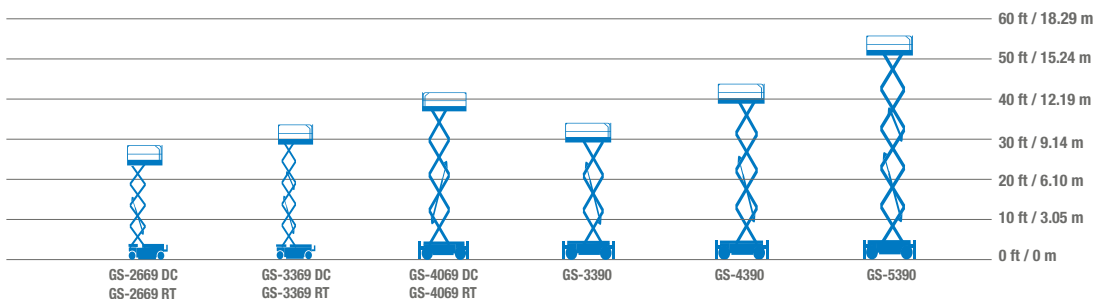

Genie® GS™ -2669 DC, GS-3369 DC & GS-4069 DC

Specifications

Models	GS-2669 DC		GS-3369 DC		GS-4069 DC	
Measurements	US	Metric	US	Metric	US	Metric
Working height max. ⁽¹⁾	32 ft 2 in	10 m	38 ft 8 in	11.96 m	46 ft 3 in	14.30 m
A Platform height max.	26 ft 2 in	8 m	32 ft 8 in	9.96 m	40 ft 3 in	12.30 m
B Platform height - stowed	4 ft 10 in	1.47 m	4 ft 10 in	1.47 m	5 ft 5 in	1.65 m
C Platform length - outside	9 ft 2 in	2.79 m	9 ft 2 in	2.79 m	9 ft 2 in	2.79 m
Platform length - outside, extended	14 ft 2 in	4.32 m	14 ft 2 in	4.32 m	14 ft 2 in	4.32 m
Slide-out platform extension deck - length	5 ft	1.52 m	5 ft	1.52 m	5 ft	1.52 m
D Platform width - outside	5 ft 3 in	1.60 m	5 ft 3 in	1.60 m	5 ft 3 in	1.60 m
Toeboard height	6 in	15 cm	6 in	15 cm	6 in	15 cm
E Height - stowed (folding rails)	8 ft 6 in	2.59 m	8 ft 6 in	2.59 m	9 ft	2.74 m
Height - stowed (rails lowered)	6 ft 3.5 in	1.92 m	6 ft 3.5 in	1.92 m	6 ft 10 in	2.08 m
F Length machine - stowed	10 ft 3 in	3.12 m	10 ft 3 in	3.12 m	10 ft 3 in	3.12 m
Length machine - stowed, extended	14 ft 9.5 in	4.50 m	14 ft 9.5 in	4.50 m	14 ft 9.5 in	4.50 m
Length machine - with outriggers	12 ft 4 in	3.76 m	12 ft 4 in	3.76 m	12 ft 4 in	3.76 m
G Width	5 ft 9 in	1.75 m	5 ft 9 in	1.75 m	5 ft 9 in	1.75 m
H Wheelbase	7 ft 6 in	2.29 m	7 ft 6 in	2.29 m	7 ft 6 in	2.29 m
I Ground clearance (center)	9.5 in	24 cm	9.5 in	24 cm	9.5 in	24 cm

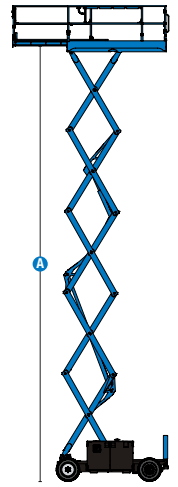

Productivity

	4/4		4/2		3/2	
Max. platform occupancy (in/out)						
Lift capacity	1,500 lb	680 kg	1,000 lb	454 kg	800 lb	363 kg
Lift capacity - extension deck extended	300 lb	136 kg	300 lb	136 kg	300 lb	136 kg
Max. platform drive height	26 ft 2 in	8 m	32 ft 8 in	9.96 m	40 ft 3 in	12.3 m
Drive speed - stowed	4.5 mph	7.2 km/h	4.5 mph	7.2 km/h	4.5 mph	7.2 km/h
Drive speed - raised	0.3 mph	0.5 km/h	0.3 mph	0.5 km/h	0.3 mph	0.5 km/h
Gradeability - stowed ⁽²⁾	35%		35%		35%	
Turning radius - inside/outside	83 in/181.2 in	2.11 m/4.6 m	83 in/181.2 in	2.11 m/4.6 m	83 in/181.2 in	2.11 m/4.6 m
Lifting speed - raise/lower	34/31 sec		39/29 sec		61/28 sec	
Tilt sensor activation (front to back/side to side)	3°/2°		3°/2°		3°/2°	
Max. outrigger leveling (front to back /side to side)	5.3°/11.7°		5.3°/11.7°		5.3°/11.7°	
Tires - Non-marking, rough terrain	12×26 in	30×66 cm	12×26 in	30×66 cm	12×26 in	30×66 cm

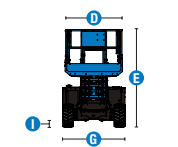
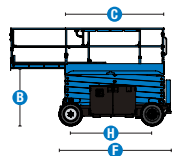

Power

Power	48V DC (8×6V 315Ah)	48V DC (8×6V 315Ah)	48V DC (8×6V 315Ah)
Hydraulic tank capacity	18 gal	68.1 L	18 gal

Weight⁽³⁾ and Floor Loading⁽⁴⁾

Weight	7,946 lb	3,604 kg	7,687 lb	3,487 kg	10,948 lb	4,966 kg
Weight with outriggers	8,796 lb	3,990 kg	8,537 lb	3,873 kg	11,798 lb	5,352 kg
Tire load max.	3,334 lb	1,512 kg	3,199 lb	1,451 kg	3,752 lb	1,702 kg
Tire contact pressure	83.3 psi	575 kPa	80 psi	551 kPa	93.3 psi	643 kPa
Occupied floor pressure	184 psf	8.83 kPa	171 psf	8.19 kPa	221 psf	10.60 kPa

Sound and Vibration Levels

Sound Pressure level (ground workstation)	70 dBA		70 dBA		70 dBA	
Sound Pressure level (platform workstation)	79 dBA		79 dBA		79 dBA	
Vibrations	< 8 ft 2 in/s ²	< 2.5 m/s ²	< 8 ft 2 in/s ²	< 2.5 m/s ²	< 8 ft 2 in/s ²	< 2.5 m/s ²

(1) The metric equivalent of working height adds 2 m to platform height. US adds 6 ft to platform height.

(2) Gradeability applies to driving on slopes and may vary depending on options and machine configurations. See operator's manual for details regarding slope ratings.

(3) Weight refers to standard configuration and may vary depending on options and/or country standards.

(4) Floor loading information is approximate and may vary depending on options and machine configurations. It should be used only with adequate safety factors.

Genie® GS™ -2669 DC, GS-3369 DC & GS-4069 DC

SKU: Standard Model

- GS-2669 DC*
- GS-3369 DC*
- **GS406901AE0042:** GS-4069 DC

* Build to Order

Option availability		S	S+	BtO
Power	Standard FLA flooded lead acid batteries	✓	✓	✓
	High capacity DC battery (Standard on GS-4069 DC)			○
	Power inverter			○
	48V DC drive system	✓	✓	✓
Platform	Folding rails, Full-height swing gate	✓	✓	✓
	Single slide-out extension deck	✓	✓	✓
	Air line to platform			○
	AC power to platform	✓	✓	✓
	Diamond plate platform deck	✓	✓	✓
	Electronic horn	✓	✓	✓
	Lanyard attachment points	✓	✓	✓
	Platform control guard (PCON)	✓	✓	✓
	Platform load sense system	✓	✓	✓
	Proportional drive and lift	✓	✓	✓
	Self-closing entry gate	✓	✓	✓
	SmartLink dual zone control system	✓	✓	✓
	Chassis	Lift Connect Telematics		○
Lift Connect with Access Manager upgrade			○	○
High floatation, foam-filled, non-marking tires			○	○
Rough Terrain, foam-filled, non-marking tires		✓	✓	✓
Auto leveling hydraulic outriggers				○
2 wheel drive		✓	✓	✓
Active oscillating axle		✓	✓	✓
Descent, tilt and motion alarm		✓	✓	✓
Dual LED flashing beacons		✓	✓	✓
Dual wheel multi-disc brakes		✓	✓	✓
On-board diagnostic system with battery charge indicator		✓	✓	✓
Rear axle sealed AC drive motors	✓	✓	✓	
Tech Pro Link connector	✓	✓	✓	

- S Standard
- S+ Standard +
- BtO Build to Order
- ✓ Standard Features
- Options



Rough Terrain Capabilities



Full Height Drive



Sealed AC Drive Motors



Genie Genuine Accessories⁽¹⁾

- Lift Tools Productivity Tools
- Lift Connect Telematics
- Tech Pro Link Handheld Device

(1) More accessories available from Genie Genuine Parts.

Product specifications are subject to change without notice or obligation. Photographs and/or drawings herein are for illustrative purposes only. Refer to the appropriate Operator's Manual for instructions on proper equipment use. Failure to follow instructions in the Operator's Manual may result in serious injury or death. The only warranty applicable to our equipment is the standard written warranty applicable to the particular product and sale and we make no other warranty, express or implied. Products and services listed may be trademarks, service marks or trade names of Terex Corporation and/or their subsidiaries in the USA and many other countries. Terex, Genie, Quality By Design, Xtra Capacity, Lift Power, Lift Guard, Lift Tools, Lift Connect and Tech Pro Link are registered trademarks of Terex Corporation or its subsidiaries.

Genie® GS™ -2669 RT, GS-3369 RT & GS-4069 RT

Specifications

Models	GS-2669 RT		GS-3369 RT		GS-4069 RT	
	US	Metric	US	Metric	US	Metric
Measurements						
Working height max. ⁽¹⁾	32 ft 2 in	10 m	38 ft 8 in	11.96 m	46 ft 3 in	14.3 m
A Platform height max.	26 ft 2 in	8 m	32 ft 8 in	9.96 m	40 ft 3 in	12.3 m
B Platform height - stowed	4 ft 10 in	1.47 m	4 ft 10 in	1.47 m	5 ft 5 in	1.65 m
C Platform length - outside	9 ft 2 in	2.79 m	9 ft 2 in	2.79 m	9 ft 2 in	2.79 m
Platform length - outside, extended	14 ft 2 in	4.32 m	14 ft 2 in	4.32 m	14 ft 2 in	4.32 m
Slide-out platform extension deck - length	5 ft	1.52 m	5 ft	1.52 m	5 ft	1.52 m
D Platform width - outside	5 ft 3 in	1.60 m	5 ft 3 in	1.60 m	5 ft 3 in	1.60 m
Toeboard height	6 in	15 cm	6 in	15 cm	6 in	15 cm
E Height - stowed (folding rails) ⁽²⁾	8 ft 6 in	2.59 m	8 ft 6 in	2.59 m	9 ft	2.74 m
Height - stowed (rails lowered)	6 ft 3.5 in	1.92 m	6 ft 3.5 in	1.92 m	6 ft 10 in	2.08 m
F Length machine - stowed	10 ft 3 in	3.12 m	10 ft 3 in	3.12 m	10 ft 3 in	3.12 m
Length machine - stowed, extended	14 ft 9 in	4.5 m	14 ft 9 in	4.5 m	14 ft 9 in	4.5 m
Length machine - with outriggers	12 ft 4 in	3.76 m	12 ft 4 in	3.76 m	12 ft 4 in	3.76 m
G Width	5 ft 9 in	1.75 m	5 ft 9 in	1.75 m	5 ft 9 in	1.75 m
H Wheelbase	7 ft 6 in	2.29 m	7 ft 6 in	2.29 m	7 ft 6 in	2.29 m
I Ground clearance (center)	9.5 in	24 cm	9.5 in	24 cm	9.5 in	24 cm

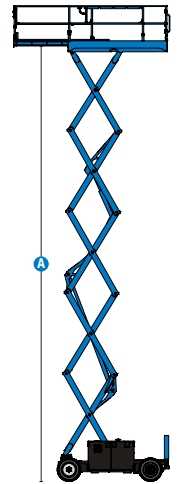

Productivity

Max. platform occupancy (in/out)	4/4	4/4	4/2	4/2	3/2	3/2
Lift capacity	1,500 lb	680 kg	1,000 lb	454 kg	800 lb	363 kg
Lift capacity - extension deck extended	300 lb	136 kg	300 lb	136 kg	300 lb	136 kg
Max. platform drive height	26 ft 2 in	5.85 m	32 ft 8 in	9.96 m	40 ft 3 in	12.3 m
Drive speed - stowed	3.5 mph	5.6 km/h	3.5 mph	5.6 km/h	3.5 mph	5.6 km/h
Drive speed - raised	0.3 mph	0.5 km/h	0.3 mph	0.5 km/h	0.3 mph	0.5 km/h
Gradeability - stowed ⁽³⁾	40%	40%	35%	35%	35%	35%
Turning radius - inside/outside	83 in/181.2 in	2.11 m/4.6 m	83 in/181.2 in	2.11 m/4.6 m	83 in/181.2 in	2.11 m/4.6 m
Lifting speed - raise/lower	34/31 sec	34/31 sec	39/29 sec	39/29 sec	61/28 sec	61/28 sec
Tilt sensor activation (front to back/side to side)	3°/2°	3°/2°	3°/2°	3°/2°	3°/2°	3°/2°
Max. outrigger leveling (front to back /side to side)	5.3°/11.7°	5.3°/11.7°	5.3°/11.7°	5.3°/11.7°	5.3°/11.7°	5.3°/11.7°

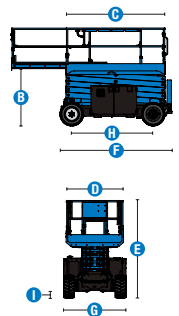

Drive

Tires - Foam-filled rough terrain	12×26 in	30×66 cm	12×26 in	30×66 cm	12×26 in	30×66 cm
-----------------------------------	----------	----------	----------	----------	----------	----------

Power

Power	Diesel	Diesel	Diesel	Diesel	Diesel	Diesel
Fuel Tank	10 gal	37.9L	10 gal	37.9L	10 gal	37.9L
Hydraulic tank capacity	18 gal	68.1L	18 gal	68.1L	18 gal	68.1L

Weight⁽⁴⁾ and Floor Loading⁽⁵⁾

Weight	7,149 lb	3,243 kg	7,599 lb	3,447 kg	10,392 lb	4,714 kg
Weight with outriggers	7,535 lb	3,629 kg	8,449 lb	3,833 kg	11,242 lb	5,100 kg
Tire load max.	2,840 lb	1,288 kg	3,019 lb	1,369 kg	3,829 lb	1,737 kg
Tire contact pressure - front, platform fully extended	70.7 psi	487 kPa	75.1 psi	518 kPa	95.3 psi	657 kPa
Occupied floor pressure	170 psf	8.15 kPa	169 psf	8.11 kPa	215 psf	10.29 kPa

Sound and Vibration Levels

Sound Pressure level (ground workstation)	85 dBA	85 dBA	85 dBA	85 dBA	85 dBA	85 dBA
Sound Pressure level (platform workstation)	79 dBA	79 dBA	79 dBA	79 dBA	79 dBA	79 dBA
Vibrations	< 8 ft 2 in/s ²	< 2.5 m/s ²	< 8 ft 2 in/s ²	< 2.5 m/s ²	< 8 ft 2 in/s ²	< 2.5 m/s ²

(1) The metric equivalent of working height adds 2 m to platform height. US adds 6 ft to platform height.

(2) Based on RT tires; deduct 2 in/5.8 cm for turf and non-marking tires.

(3) Gradeability applies to driving on slopes and may vary depending on options and machine configurations. See operator's manual for details regarding slope ratings.

(4) Weight refers to standard configuration and may vary depending on options and/or country standards.

(5) Floor loading information is approximate and may vary depending on options and machine configurations. It should be used only with adequate safety factors.

Genie® GS™ -2669 RT, GS-3369 RT & GS-4069 RT

SKU: Standard Model

- **GS266901AF0007:** GS-2669 RT
- **GS266901AF0005:** GS-2669 RT, AC Generator (110V/60Hz, 3kW)

* Build to Order

SKU: Standard Model

- **GS336901AF0006:** GS-3369 RT
- **GS336901AF0004:** GS-3369 RT, Auto leveling outriggers
- **GS336901AF0008:** GS-3369 RT, 3kW AC Generator 110V/60Hz
- **GS406901AF0006:** GS-4069 RT

Option availability		S	S+	BtO
Power	24.8 hp, 18.5kW Kubota D1105, Diesel, T4i/T4f, Stage IIIA/V, CN III	✓	✓	✓
	Cold weather package			○
Platform	Folding rails, Full-height swing gate	✓	✓	✓
	Single slide-out extension deck	✓	✓	✓
	Air line to platform			○
	3kW AC Generator, 110V/50Hz			○
	AC power to platform	✓	✓	✓
	Diamond plate platform deck	✓	✓	✓
	Electronic horn	✓	✓	✓
	Lanyard attachment points	✓	✓	✓
	Platform control guard (PCON)	✓	✓	✓
	Platform control with fault indicator	✓	✓	✓
	Platform load sense system	✓	✓	✓
	Proportional drive and lift	✓	✓	✓
	Self-closing entry gate	✓	✓	✓
	Chassis	Lift Connect Telematics		○
Lift Connect with Access Manager upgrade			○	○
Biodegradable hydraulic oil				○
Cold weather hydraulic oil				○
Rough Terrain, foam-filled tires		✓	✓	✓
Rough Terrain, foam-filled, non-marking tires			○	○
Auto leveling hydraulic outriggers				○
Dual LED flashing beacons		✓	✓	✓
4 wheel drive		✓	✓	✓
Active oscillating axle		✓	✓	✓
Descent, tilt and motion alarm		✓	✓	✓
Dual wheel multi-disc brakes	✓	✓	✓	
High floatation, foam filled tires (GS-2669, GS-3369)	✓	✓	✓	

- S Standard
- S+ Standard +
- BtO Build to Order
- ✓ Standard Features
- Options



4 Wheel Drive



Full Height Drive



Swing-Out Engine Tray



Genie Genuine Accessories⁽¹⁾

- Lift Tools Productivity Tools
- Lift Connect Telematics
- Tech Pro Link Handheld Device

(1) More accessories available from Genie Genuine Parts.

Product specifications are subject to change without notice or obligation. Photographs and/or drawings herein are for illustrative purposes only. Refer to the appropriate Operator's Manual for instructions on proper equipment use. Failure to follow instructions in the Operator's Manual may result in serious injury or death. The only warranty applicable to our equipment is the standard written warranty applicable to the particular product and sale and we make no other warranty, express or implied. Products and services listed may be trademarks, service marks or trade names of Terex Corporation and/or their subsidiaries in the USA and many other countries. Terex, Genie, Quality By Design, Xtra Capacity, Lift Power, Lift Guard, Lift Tools, Lift Connect and Tech Pro Link are registered trademarks of Terex Corporation or its subsidiaries.

Genie® GS™ -3390, GS-4390 & GS-5390

Specifications

Models	GS-3390		GS-4390		GS-5390	
Measurements	US	Metric	US	Metric	US	Metric
Working height max. ⁽¹⁾	39ft	12.06 m	49ft	15.11 m	59ft	18.15 m
A Platform height max.	33ft	10.06 m	43ft	13.11 m	53ft	16.15 m
B Platform height - stowed ⁽²⁾	5ft 1 in	1.55 m	5ft 11 in	1.80 m	6ft 7.5 in	2.02 m
C Platform length - outside	13ft 0.5 in	3.98 m	13ft 0.5 in	3.98 m	13ft 0.5 in	3.98 m
Platform length - Outside, extended single deck	17ft 6.25 in	5.34 m	17ft 6.25 in	5.34 m	17ft 6.25 in	5.34 m
D Platform length - Outside, extended dual deck	21ft 6.5 in	6.57 m	21ft 6.5 in	6.57 m	21ft 6.5 in	6.57 m
E Slide-out platform extension deck - front	5ft	1.52 m	5ft	1.52 m	5ft	1.52 m
F Slide-out platform extension deck - rear	4ft	1.22 m	4ft	1.22 m	4ft	1.22 m
G Platform width - outside	6ft	1.83 m	6ft	1.83 m	6ft	1.83 m
H Height - stowed (folding rails)	8ft 10.5 in	2.71 m	9ft 7.5 in	2.93 m	10ft 4 in	3.15 m
Height - stowed (rails lowered)	6ft 7.75 in	2.03 m	7ft 4.75 in	2.25 m	8ft 1.25 in	2.47 m
I Length - stowed, single deck	12ft 11.25 in	3.94 m	12ft 11.25 in	3.94 m	*	
Length - stowed, dual deck	13ft 0.5 in	3.98 m	13ft 0.5 in	3.98 m	-	
Length - stowed, with outriggers	16ft	4.88 m	16ft	4.88 m	16ft	4.88 m
Length - extended, single deck	17ft 8.5 in	5.40 m	17ft 8.5 in	5.40 m	17ft 8.5 in	5.40 m
Length - extended, dual deck	21ft 6.5 in	6.57 m	21ft 6.5 in	6.57 m	21ft 6.5 in	6.57 m
J Width (standard tires)	7ft 8 in	2.34 m	7ft 8 in	2.34 m	7ft 8 in	2.34 m
K Wheelbase	9ft 4 in	2.84 m	9ft 4 in	2.84 m	9ft 4 in	2.84 m
L Ground clearance (center)	1ft 2 in	36 cm	1ft 2 in	36 cm	1ft 2 in	36 cm

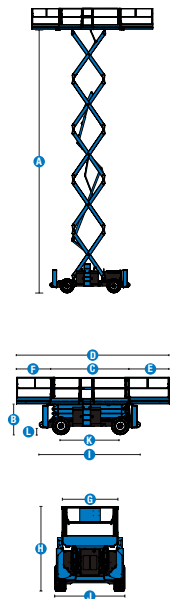

Productivity

Max. platform occupancy (in/out)	7/7		7/7		4/4	
Lift capacity	2,500 lb	1,134 kg	1,500 lb	680 kg	1,500 lb	680 kg
Lift capacity - extension deck extended	500 lb	227 kg	500 lb	227 kg	500 lb	227 kg
Max. platform drive height	33ft	10.06 m	43ft	13.11 m	33ft	10.06 m
Drive speed - stowed	5.0 mph	8.0 km/h	5.0 mph	8.0 km/h	5.0 mph	8.0 km/h
Drive speed - raised	0.7 mph	1.1 km/h	0.7 mph	1.1 km/h	0.7 mph	1.1 km/h
Gradeability - stowed ⁽³⁾	50%		50%		40%	
Turning radius - inside/outside	7ft 1 in/17ft 6 in	2.16 m/5.33 m	7ft 1 in/17ft 6 in	2.16 m/5.33 m	7ft 1 in/17ft 6 in	2.16 m/5.33 m
Lifting speed - raise/lower	45/29 sec		45/39 sec		60/49 sec	
Max. outrigger leveling (front to back /side to side)	7° / 12°		7° / 12°		7° / 12°	
Tires - Foam-filled rough terrain	12x33 in	30x84 cm	12x33 in	30x84 cm	12x33 in	30x84 cm

Power

Power	Diesel		Diesel		Diesel	
Fuel Tank	20 gal	75.7 L	20 gal	75.7 L	20 gal	75.7 L
Hydraulic tank capacity	30 gal	113.6 L	30 gal	113.6 L	30 gal	113.6 L
Weight	11,977 lb	5,433 kg	12,894 lb	5,849 kg	16,567 lb	7,515 kg
Weight with outriggers	13,652 lb	6,195 kg	14,611 lb	6,628 kg	16,567 lb	7,515 kg
Additional weight, optional dual deck	784 lb	356 kg	784 lb	356 kg	784 lb	356 kg
Additional weight, optional super deck	906 lb	411 kg	906 lb	411 kg	906 lb	411 kg
Additional weight, optional generator	105 lb	48 kg	105 lb	48 kg	105 lb	48 kg
Tire load max.	4,734 lb	2,147 kg	4,722 lb	2,142 kg	5,294 lb	2,401 kg
Tire contact pressure - front, platform fully extended	115.5 psi	796 kPa	115.2 psi	794 kPa	129.1 psi	890 kPa
Occupied floor pressure	167 psf	8.00 kPa	167 psf	7.98 kPa	187 psf	8.94 kPa

Sound and Vibration Levels

Sound Pressure level (ground workstation)	< 88 dBA		< 88 dBA		< 88 dBA	
Sound Pressure level (platform workstation)	< 78 dBA		< 78 dBA		< 78 dBA	
Vibrations	< 8 ft 2 in/s ²	< 2.5 m/s ²	< 8 ft 2 in/s ²	< 2.5 m/s ²	< 8 ft 2 in/s ²	< 2.5 m/s ²

(1) The metric equivalent of working height adds 2m to platform height. US adds 6ft to platform height.

(2) Based on RT tires; deduct 2 in/5.8 cm for turf and non-marking tires.

(3) Gradeability applies to driving on slopes and may vary depending on options and machine configurations. See operator's manual for details regarding slope ratings.

(4) Weight refers to standard configuration and may vary depending on options and/or country standards.

(5) Floor loading information is approximate and may vary depending on options and machine configurations. It should be used only with adequate safety factors.

* GS-5390 comes standard with outriggers. Machine length with outriggers represents overall length.

Genie® GS™ -3390, GS-4390 & GS-5390

SKU: Standard Model

- GS-3390, Oscillating Axle*
- **GS439001AD0001:** GS-4390, 2kW AC Generator 110V/60Hz

* Build to Order

SKU: Standard Model

- **GS539001AF0001:** GS-5390, Auto leveling outriggers
- **GS539001AE0031:** GS-5390, Auto leveling outriggers, 2kW AC Generator 110V/60Hz
- **GS539001AE0030:** GS-5390, Ford Gas/LPG, Auto leveling outriggers

Option availability		S	S+	BtO
Power	48.7 hp, 36.3kW, Deutz D2.9L, Diesel, T4f		✓	
	60 hp, 44.7 kW, Ford 2.5L, Gas/LPG	✓		✓
	Cold weather package			○
Platform	Folding rails, Full-height swing gate	✓	✓	✓
	Single slide-out extension deck	✓	✓	✓
	Dual slide-out extension deck			○
	Air line to platform			○
	2kW AC Generator, 110V/60Hz			○
	AC power to platform	✓	✓	✓
	Diamond plate platform deck	✓	✓	✓
	Electronic horn	✓	✓	✓
	Lanyard attachment points	✓	✓	✓
	Platform control guard (PCON)	✓	✓	✓
	Platform control with fault indicator	✓	✓	✓
	Platform load sense system	✓	✓	✓
	Proportional drive and lift	✓	✓	✓
Self-closing entry gate	✓	✓	✓	
Chassis	Lift Connect Telematics		○	○
	Lift Connect with Access Manager upgrade		○	○
	Biodegradable hydraulic oil			○
	Cold weather hydraulic oil			○
	High floatation, foam-filled tires		○	○
	Rough Terrain, foam-filled tires	✓	✓	✓
	Rough Terrain, foam-filled, non-marking tires		○	○
	Active oscillating axle			○
	Hydraulic oil cooler			○
	LPG tank 7 gal /33.5 lb (incl. in Ford engine)		○	○
	4 wheel drive	✓	✓	✓
	Auto leveling hydraulic outriggers			○
Descent, tilt and motion alarm	✓	✓	✓	
Dual LED flashing beacons	✓	✓	✓	

- S Standard
- S+ Standard +
- BtO Build to Order
- ✓ Standard Features
- Options



4 Wheel Drive



Optional Oscillating axle



Slide-Out Engine Tray



Genie Genuine Accessories⁽¹⁾

- Lift Tools Productivity Tools
- Lift Connect Telematics
- Tech Pro Link Handheld Device

(1) More accessories available from Genie Genuine Parts.

Product specifications are subject to change without notice or obligation. Photographs and/or drawings herein are for illustrative purposes only. Refer to the appropriate Operator's Manual for instructions on proper equipment use. Failure to follow instructions in the Operator's Manual may result in serious injury or death. The only warranty applicable to our equipment is the standard written warranty applicable to the particular product and sale and we make no other warranty, express or implied. Products and services listed may be trademarks, service marks or trade names of Terex Corporation and/or their subsidiaries in the USA and many other countries. Terex, Genie, Quality By Design, Xtra Capacity, Lift Power, Lift Guard, Lift Tools, Lift Connect and Tech Pro Link are registered trademarks of Terex Corporation or its subsidiaries.

GENIE® ARTICULATING Z®-BOOM LIFTS

Genie's versatile line-up of articulating Z® boom lifts allows operators to work efficiently on a range of worksites with one machine. The unique design of these articulated lifts allows them to reach up and over obstacles on sites ranging from residential and commercial to general construction and more. With diesel, hybrid and electric options, Genie's lineup of articulating boom lifts provides flexibility for a wide range of jobsites, including work indoors or in areas with noise and emissions restrictions.

THREE

POWER OPTIONS

MAXIMUM

VERSATILITY

HIGH

RELIABILITY

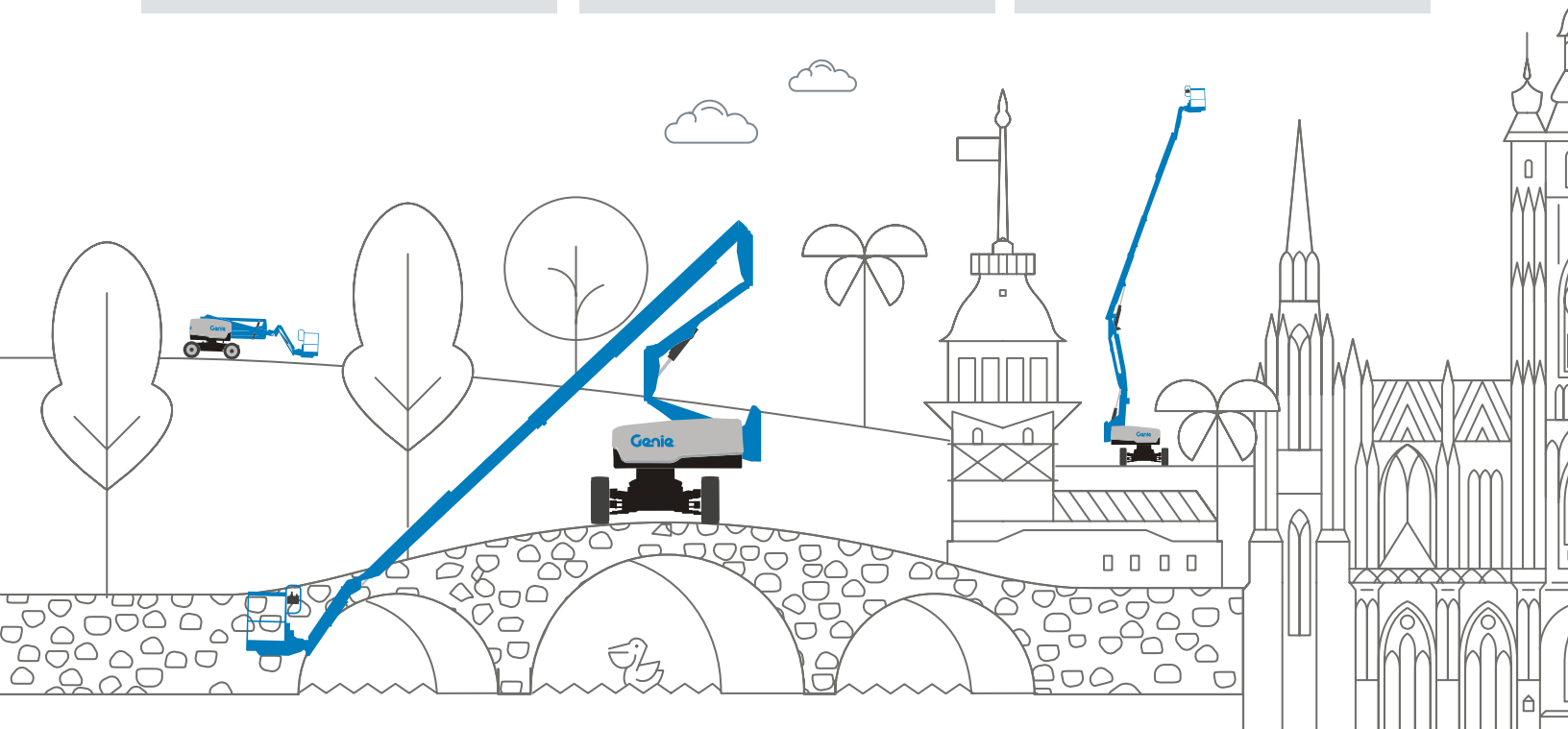

Specifications

Articulating Z[®]-Boom Lifts

MODEL	MAX. PLATFORM HEIGHT	HORIZONTAL REACH	LIFT CAPACITY	UP & OVER CLEARANCE	WIDTH*	TRANSPORT LENGTH*	WEIGHT*
Narrow Articulating Z-Boom Lifts							
Z [®] -30/20N	30 ft	21 ft 5 in	500 lb	12 ft 8 in	3 ft 11 in	11 ft 6 in	14,421 lb
Z-30/20N RJ	29 ft 2 in	20 ft 6 in	500 lb	12 ft 8 in	3 ft 11 in	12 ft	14,562 lb
Z-34/22N	34 ft 6 in	22 ft 3 in	500 lb	15 ft 3 in	4 ft 10 in	13 ft 9 in	11,415 lb
Z-40/23N	40 ft 5 in	22 ft 8 in	500 lb	21 ft 3 in	4 ft 11 in	21 ft 5 in	15,230 lb
Z-40/23N RJ	40 ft 5 in	22 ft 8 in	500 lb	21 ft 3 in	4 ft 11 in	21 ft 5 in	15,300 lb
Electric & Hybrid Articulating Z-Boom Lifts							
Z-34/22 DC	34 ft 6 in	22 ft 3 in	500 lb	15 ft	5 ft 8 in	13 ft 5 in	11,420 lb
Z-45/25J DC	45 ft 9 in	25 ft 1 in	500 lb	23 ft 9 in	5 ft 10.25 in	22 ft 5 in	16,315 lb
Z-45 DC & Z-45 FE	45 ft 8 in	22 ft 9 in	660 lb	24 ft 7 in	7 ft 6 in	20 ft 1 in	14,064 lb
Z-60 DC & Z-60 FE	59 ft 7 in	36 ft 7 in	500 lb	24 ft 3 in	8 ft 2 in	26 ft 9 in	16,600 lb
Engine-Powered Articulating Z-Boom Lifts							
Z-34/22 IC	34 ft 7 in	22 ft 3 in	500 lb	15 ft 1 in	6 ft 1 in	13 ft 6 in	11,010 lb
Z-45 XC™	45 ft 6 in	24 ft 9 in	660/1,000 lb	24 ft 5 in	7 ft 6 in	21 ft 10 in	16,360 lb
Z-45 HF	45 ft 6 in	24 ft 9 in	600 lb	24 ft 5 in	8 ft 5 in	21 ft 10 in	16,050 lb
Z-62/40	61 ft 11 in	40 ft 9 in	500 lb	25 ft 7 in	8 ft 2 in	24 ft 5 in	22,665 lb
Z-62/40 TRAX™	62 ft 1 in	40 ft 9 in	500 lb	25 ft 7 in	8 ft 1.6 in	25 ft 5 in	26,933 lb
Z-80/60	78 ft	60 ft	500 lb	29 ft	8 ft 2 in	24 ft 10.5 in	38,000 lb
ZX [®] -135/70	135 ft	69 ft 9 in	600 lb	75 ft 6 in	8 ft 2 in**	42 ft 5 in	46,500 lb

* With standard configuration. Will vary depending on options and/or country standards.

**Axles retracted

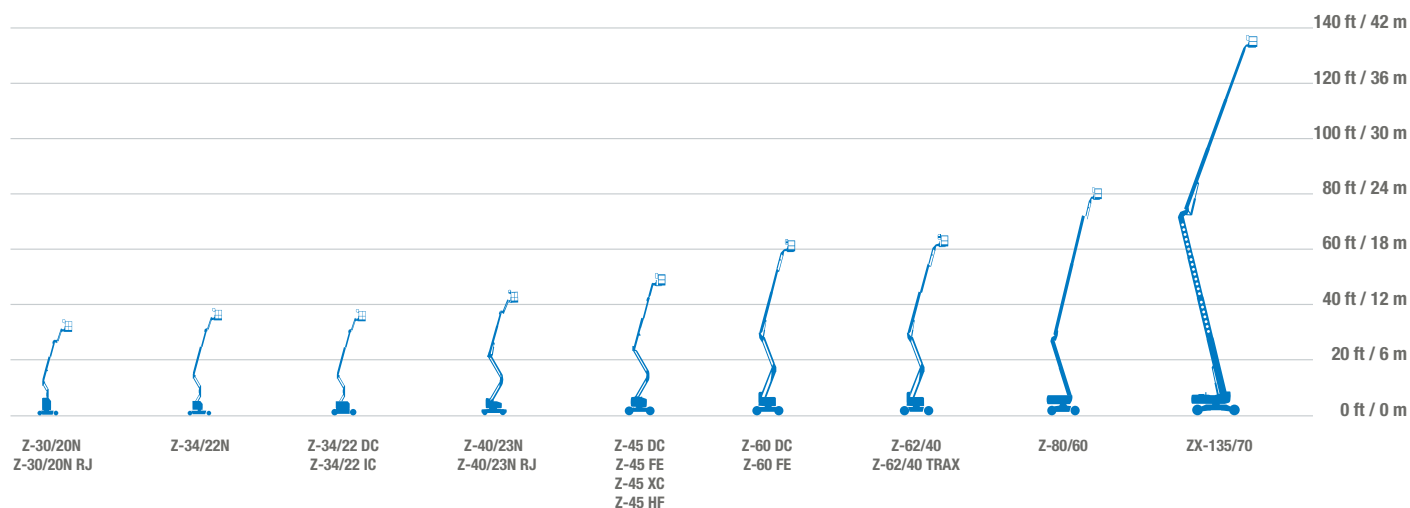

Genie® Z[®]-30/20N & Z-30/20N RJ

Specifications

Models	Z-30/20N		Z-30/20N RJ	
Measurements	US	Metric	US	Metric
Working height max. ⁽¹⁾	36 ft	11.14 m	35 ft 2 in	10.89 m
Platform height max.	30 ft	9.14 m	29 ft 2 in	8.89 m
Horizontal reach max.	21 ft 5 in	6.53 m	20 ft 6 in	6.25 m
Up and over clearance max.	12 ft 8 in	3.86 m	12 ft 8 in	3.86 m
A Platform length	2 ft 6 in	0.76 m	2 ft 6 in	0.76 m
B Platform width	3 ft 10 in	1.17 m	3 ft 10 in	1.17 m
C Height - stowed	6 ft 6.5 in	2.00 m	6 ft 6.5 in	2.00 m
D Length - stowed	16 ft 9 in	5.11 m	17 ft 5 in	5.31 m
E Storage height	6 ft 7 in	2.08 m	7 ft 4 in	2.24 m
F Storage length	11 ft 6 in	3.5 m	12 ft	3.66 m
G Width	3 ft 11 in	1.19 m	3 ft 11 in	1.19 m
H Wheelbase	5 ft 2 in	1.58 m	5 ft 2 in	1.58 m
I Ground clearance - center	3.5 in	0.09 m	3.5 in	0.09 m

Productivity

Lift capacity max. - unrestricted	500 lb	227 kg	500 lb	227 kg
Platform rotation	180°		180°	
Jib length	4 ft	1.22 m	4 ft	1.22 m
Vertical jib rotation	139°		139°	
Horizontal jib rotation	—		180°	
Turntable rotation	355°		355°	
Turntable tailswing	0 in	0 cm	0 in	0 cm
Drive speed - stowed ⁽²⁾	3.0 mph	4.8 km/h	3.0 mph	4.8 km/h
Drive speed - raised	0.68 mph	1.1 km/h	0.68 mph	1.1 km/h
Gradeability - stowed ⁽²⁾	35%		35%	
Tilt sensor activation (front to back/side to side)	2.5°- 4.5°/4.5°		2.5°- 4.5°/4.5°	
Turning radius - inside/outside	5 ft 5 in/10 ft 7 in	1.65 m/3.23 m	5 ft 5 in/10 ft 7 in	1.65 m/3.23 m
Tires (solid, non-marking)	22×7×17.75 in	56×18×45 cm	22×7×17.75 in	56×18×45 cm

Power

Power	48V DC (8×6V 350Ah)	48V DC (8×6V 350Ah)
Auxiliary power unit	24V DC	24V DC
Hydraulic tank capacity	4 gal	15.1 L

Weight⁽³⁾ and Floor Loading⁽⁴⁾

Weight	14,421 lb	6,541 kg	14,562 lb	6,605 kg
Tire contact pressure	103 psi	710 kPa	103 psi	710 kPa
Occupied floor pressure (tires)	535 psf	25.62 kPa	537 psf	25.71 kPa

Sound and Vibration Levels

Sound Pressure level (ground workstation)	< 70 dBA	< 70 dBA
Sound Pressure level (platform workstation)	< 70 dBA	< 70 dBA
Vibrations	8 ft 2 in/s ²	2.5 m/s ²

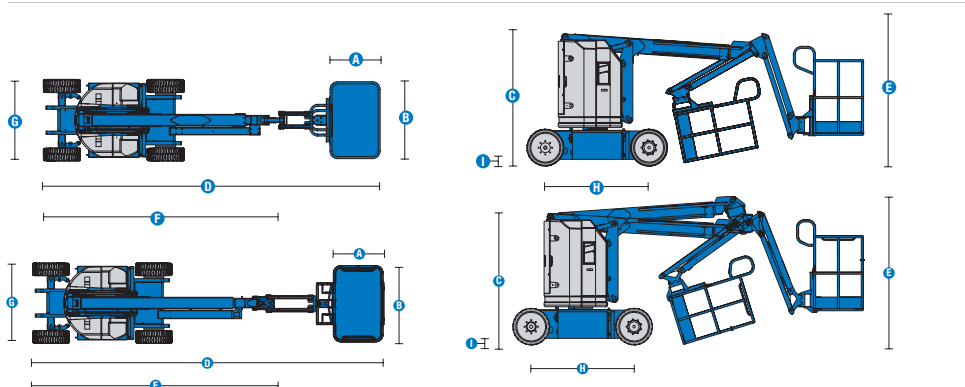

- (1) The metric equivalent of working height adds 2 m to platform height. The imperial equivalent adds 6 ft to platform height.
- (2) Gradeability applies to driving on slopes and may vary depending on options and machine configurations. See operator's manual for details regarding slope ratings.
- (3) Weight refers to standard configuration and may vary depending on options and/or country standards.
- (4) Floor loading information is approximate and may vary depending on options and machine configurations. It should be used only with adequate safety factors.

Range of motion Z-30/20N

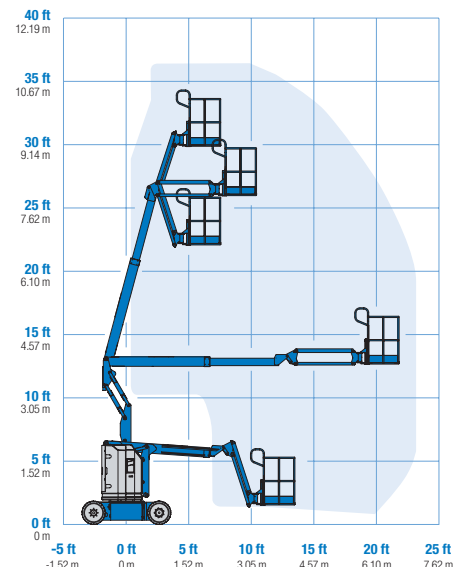

Range of motion Z-30/20N RJ

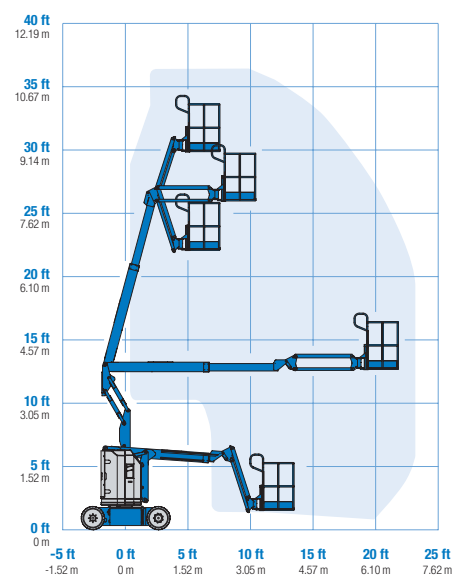

Jib range of motion Z-30/20N RJ

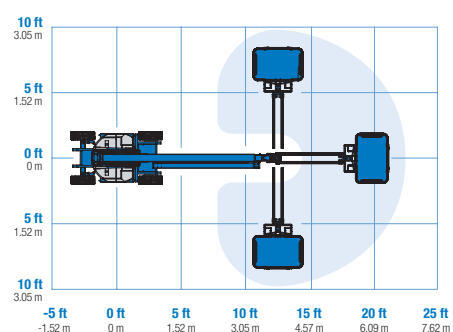

Genie® Z®-30/20N & Z-30/20N RJ

SKU: Standard Model

- **Z30N0001AE0001:** Z-30/20N, DC Power, 2WD
- **Z30NRJ01AE0003:** Z-30/20N RJ, DC Power, 2WD
- **Z30NRJ01AE0001:** Z-30/20N RJ, DC Power, Swing gate, 2WD

* Build to Order

Option availability	S	S+	BtO
Power			
Standard FLA flooded lead acid battery	✓	✓	✓
AGM Maintenance-free batteries		○	○
Battery charge indicator (BCI)			○
Low voltage interrupt (LVI) with battery charge indicator (BCI)			○
Power Inverter, 800W, 120V AC, 60Hz		○	○
Platform			
3ft 10in/1.17m steel platform	✓	✓	✓
Air line to platform			○
Aircraft protection kit			○
Control box covers		○	○
Lift Guard Half Mesh panels with swing gate			○
Light Package: drive and work lights		○	○
Platform auxiliary top rail			○
Platform swing gate			○
4ft/1.2m Jib	✓	✓	✓
AC Power cord to platform	✓	✓	✓
Drive enable system	✓	✓	✓
Horn	✓	✓	✓
Lift Guard Contact Alarm	✓	✓	✓
Platform load sense system	✓	✓	✓
Proportional controls	✓	✓	✓
Self-leveling platform	✓	✓	✓
Travel alarm package: flashing beacons, descent, travel and tilt alarms	✓	✓	✓
Chassis			
Lift Connect Telematics	✓	✓	✓
Lift Connect with Access Manager upgrade		○	○
Biodegradable hydraulic oil			○
Cold weather hydraulic oil			○
Fire resistant hydraulic oil			○
Hostile environment kit			○
Chassis tilt drive function cut-out	✓	✓	✓
Dual parallelogram lift linkage	✓	✓	✓
Hour meter	✓	✓	✓
Solid, non-marking tires	✓	✓	✓
Zero tail swing	✓	✓	✓

- S Standard
- S+ Standard +
- BtO Build to Order
- ✓ Standard Features
- Options



Zero Tailswing



Narrow Access



Rotating Jib



Genie Genuine Accessories⁽¹⁾

- Lift Tools Productivity Tools
- Lift Connect Telematics
- Tech Pro Link Handheld Device

(1) More accessories available from Genie Genuine Parts.

Product specifications are subject to change without notice or obligation. Photographs and/or drawings herein are for illustrative purposes only. Refer to the appropriate Operator's Manual for instructions on proper equipment use. Failure to follow instructions in the Operator's Manual may result in serious injury or death. The only warranty applicable to our equipment is the standard written warranty applicable to the particular product and sale and we make no other warranty, express or implied. Products and services listed may be trademarks, service marks or trade names of Terex Corporation and/or their subsidiaries in the USA and many other countries. Terex, Genie, Quality By Design, Xtra Capacity, Lift Power, Lift Guard, Lift Tools, Lift Connect and Tech Pro Link are registered trademarks of Terex Corporation or its subsidiaries.

07/22

Genie® Z®-34/22N

Specifications

Models	Z-34/22N	
Measurements	US	Metric
Working height max. ⁽¹⁾	40 ft 6 in	12.52 m
Platform height max.	34 ft 6 in	10.52 m
Horizontal reach max.	22 ft 3 in	6.78 m
Up and over clearance max.	15 ft 3 in	4.65 m
A Platform length	2 ft 6 in	0.76 m
B Platform width	4 ft 8 in	1.42 m
C Height - stowed (tires)	6 ft 7 in	2.00 m
D Length - stowed (tires)	18 ft 9 in	5.72 m
E Storage height	7 ft 5 in	2.26 m
F Storage length	13 ft 9 in	4.19 m
G Width	4 ft 10 in	1.47 m
H Wheelbase	6 ft 2 in	1.88 m
I Ground clearance - center	5.5 in	0.14 m

Productivity

Lift capacity max. - unrestricted	500 lb	227 kg
Platform rotation	180°	180°
Jib length	4 ft	1.22 m
Vertical jib rotation	139°	139°
Turntable rotation	355°	355°
Turntable tailswing	0 in	0 cm
Drive speed - stowed ⁽²⁾	4.0 mph	6.4 km/h
Drive speed - raised	0.68 mph	1.1 km/h
Gradeability - stowed ⁽²⁾	35%	35%
Tilt sensor activation (front to back/side to side)	2.5° - 4.5° / 4.5°	2.5° - 4.5° / 4.5°
Turning radius - inside/outside	7 ft/13 ft 5 in	2.13 m/4.08 m
Tires (solid, non-marking)	22×7×17.75 in	56×18×45 cm

Power

Power	48V DC (8×6V 315Ah)	48V DC (8×6V 315Ah)
Auxiliary power unit	24V DC	24V DC
Hydraulic tank capacity	4 gal	15.1 L

Weight⁽³⁾ and Floor Loading⁽⁴⁾

Weight (tires)	11,415 lb	5,178 kg
Tire contact pressure	103 psi	710 kPa
Occupied floor pressure (tires)	308 psf	14.75 kPa

Sound and Vibration Levels

Sound Pressure level (ground workstation)	< 70 dBA	< 70 dBA
Sound Pressure level (platform workstation)	< 70 dBA	< 70 dBA
Vibrations	8 ft 2 in/s ²	2.5 m/s ²

Range of motion Z-34/22N

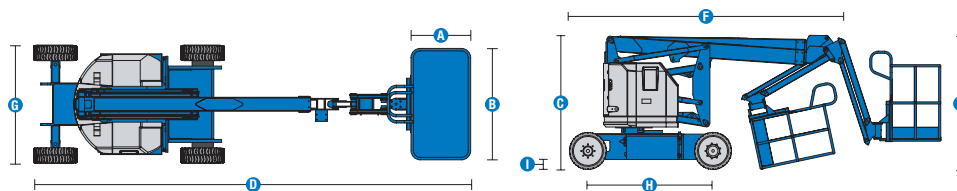
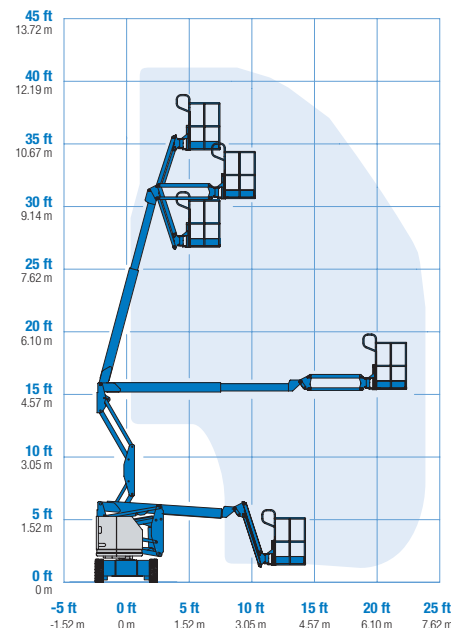

(1) The metric equivalent of working height adds 2m to platform height. The imperial equivalent adds 6ft to platform height.
 (2) Gradeability applies to driving on slopes and may vary depending on options and machine configurations. See operator's manual for details regarding slope ratings.
 (3) Weight refers to standard configuration and may vary depending on options and/or country standards.
 (4) Floor loading information is approximate and may vary depending on options and machine configurations. It should be used only with adequate safety factors.

Genie® Z®-34/22N

SKU: Standard Model

- **Z34N0001AE0003:** Z-34/22N, DC Power, 2WD
- **Z34N0001AV0018:** Z-34/22N, DC Power, BCI, LVI, 2WD

* Build to Order

Option availability		S	S+	BtO
Power	Standard FLA flooded lead acid battery	✓	✓	✓
	AGM Maintenance-free batteries		○	○
	Battery charge indicator (BCI)			○
	Low voltage interrupt (LVI) with battery charge indicator (BCI)			○
	Power Inverter, 800W, 120V AC, 60Hz		○	○
Platform	3ft 10in/1.17m steel platform			○
	4ft 8in/1.42m steel platform	✓	✓	✓
	Air line to platform			○
	Aircraft protection kit			○
	Control box covers		○	○
	Lift Guard Half Mesh panels with swing gate			○
	Light Package: drive and work lights		○	○
	Platform auxiliary top rail			○
	Platform swing gate			○
	4ft/1.2m Jib	✓	✓	✓
	AC Power cord to platform	✓	✓	✓
	Drive enable system	✓	✓	✓
	Horn	✓	✓	✓
	Lift Guard Contact Alarm	✓	✓	✓
	Platform load sense system	✓	✓	✓
	Proportional controls	✓	✓	✓
Self-leveling platform	✓	✓	✓	
Travel alarm package: flashing beacons, descent, travel and tilt alarms	✓	✓	✓	
Chassis	Lift Connect Telematics	✓	✓	✓
	Lift Connect with Access Manager upgrade		○	○
	Biodegradable hydraulic oil			○
	Cold weather hydraulic oil			○
	Fire resistant hydraulic oil			○
	Hostile environment kit			○
	Chassis tilt drive function cut-out	✓	✓	✓
	Dual parallelogram lift linkage	✓	✓	✓
	Hour meter	✓	✓	✓
Solid, non-marking tires	✓	✓	✓	

- S Standard
- S+ Standard +
- BtO Build to Order
- ✓ Standard Features
- Options



Quiet Operation



Narrow Access



Non-Marking Option



Genie Genuine Accessories⁽¹⁾

- Lift Tools Productivity Tools
- Lift Connect Telematics
- Tech Pro Link Handheld Device

(1) More accessories available from Genie Genuine Parts.

Product specifications are subject to change without notice or obligation. Photographs and/or drawings herein are for illustrative purposes only. Refer to the appropriate Operator's Manual for instructions on proper equipment use. Failure to follow instructions in the Operator's Manual may result in serious injury or death. The only warranty applicable to our equipment is the standard written warranty applicable to the particular product and sale and we make no other warranty, express or implied. Products and services listed may be trademarks, service marks or trade names of Terex Corporation and/or their subsidiaries in the USA and many other countries. Terex, Genie, Quality By Design, Xtra Capacity, Lift Power, Lift Guard, Lift Tools, Lift Connect and Tech Pro Link are registered trademarks of Terex Corporation or its subsidiaries.

Genie® Z[®]-40/23N & Z-40/23N RJ

Specifications

Models	Z-40/23N		Z-40/23N RJ	
Measurements	US	Metric	US	Metric
Working height max. ⁽¹⁾	46 ft 5 in	14.32 m	46 ft 5 in	14.32 m
Platform height max.	40 ft 5 in	12.32 m	40 ft 5 in	12.32 m
Horizontal reach max.	22 ft 8 in	6.91 m	22 ft 8 in	6.91 m
Up and over clearance max.	21 ft 3 in	6.48 m	21 ft 3 in	6.48 m
A Platform length	2 ft 6 in	0.76 m	2 ft 6 in	0.76 m
B Platform width	4 ft 8 in	1.42 m	3 ft 10 in	1.17 m
C Height - stowed (tires)	6 ft 6 in	1.98 m	6 ft 6 in	1.98 m
D Length - stowed (tires)	21 ft 5 in	6.53 m	21 ft 5 in	6.53 m
E Width	4 ft 11 in	1.50 m	4 ft 11 in	1.50 m
F Wheelbase	6 ft 5 in	1.96 m	6 ft 5 in	1.96 m
G Ground clearance - center	9.5 in	0.24 m	9.5 in	0.24 m

Productivity

Lift capacity max. - unrestricted	500 lb	227 kg	500 lb	227 kg
Platform rotation	180°	180°	180°	180°
Jib length	4 ft	1.22 m	4 ft	1.22 m
Vertical jib rotation	128°	128°	128°	128°
Horizontal jib rotation	—	—	180°	180°
Turntable rotation	355°	355°	355°	355°
Turntable tailswing	5 in	0.13 m	5 in	0.13 m
Drive speed - stowed ⁽²⁾	4.5 mph	7.2 km/h	4.5 mph	7.2 km/h
Drive speed - raised	0.68 mph	1.1 km/h	0.68 mph	1.1 km/h
Gradeability - stowed ⁽²⁾	30 %	30 %	30 %	30 %
Tilt sensor activation (front to back/side to side)	2.5° - 4.5° / 4.5°	2.5° - 4.5° / 4.5°	2.5° - 4.5° / 4.5°	2.5° - 4.5° / 4.5°
Turning radius - inside/outside	2 ft 11 in / 10 ft 6 in	0.87 m / 3.20 m	2 ft 11 in / 10 ft 6 in	0.87 m / 3.20 m
Tires (solid, non-marking)	22×7× 17.75 in	0.56×0.18× 0.45 m	22×7× 17.75 in	0.56×0.18× 0.45 m

Power

Power	48V DC (8×6V 350Ah)	48V DC (8×6V 350Ah)	48V DC (8×6V 350Ah)	48V DC (8×6V 350Ah)
Drive system	48V 3-Phase AC	48V 3-Phase AC	48V 3-Phase AC	48V 3-Phase AC
Auxiliary power unit	24V DC	24V DC	24V DC	24V DC
Hydraulic tank capacity	8 gal	30.3 L	8 gal	30.3 L

Weight⁽³⁾ and Floor Loading⁽⁴⁾

Weight (tires)	15,230 lb	6,908 kg	15,300 lb	6,940 kg
Tire contact pressure	200 psi	1379 kPa	200 psi	1379 kPa
Occupied floor pressure (tires)	372 psf	17.8 kPa	372 psf	17.8 kPa

Sound and Vibration Levels

Sound Pressure level (ground workstation)	< 70 dBA	< 70 dBA	< 70 dBA	< 70 dBA
Sound Pressure level (platform workstation)	< 70 dBA	< 70 dBA	< 70 dBA	< 70 dBA
Vibrations	8 ft 2 in/s ²	2.5 m/s ²	8 ft 2 in/s ²	2.5 m/s ²

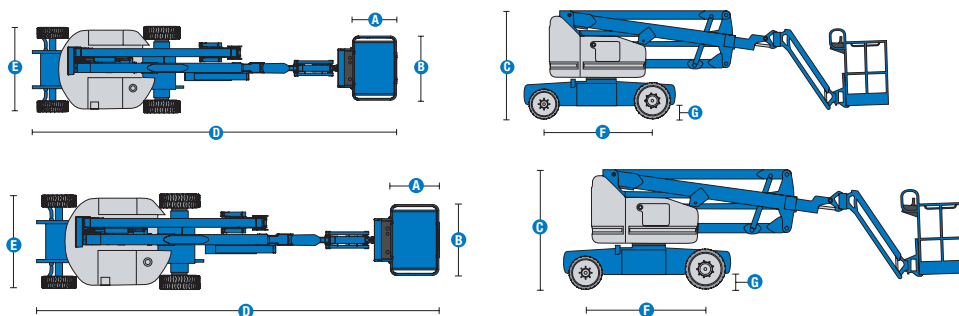

- (1) The metric equivalent of working height adds 2m to platform height. The imperial equivalent adds 6ft to platform height.
- (2) Gradeability applies to driving on slopes and may vary depending on options and machine configurations. See operator's manual for details regarding slope ratings.
- (3) Weight refers to standard configuration and may vary depending on options and/or country standards.
- (4) Floor loading information is approximate and may vary depending on options and machine configurations. It should be used only with adequate safety factors.

Range of motion Z-40/23N

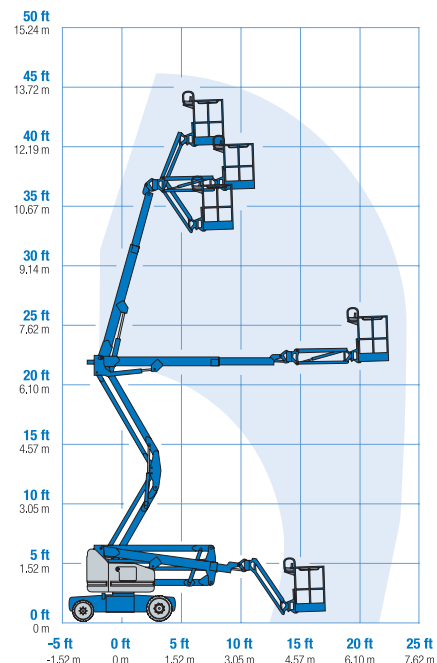

Range of motion Z-40/23 N RJ

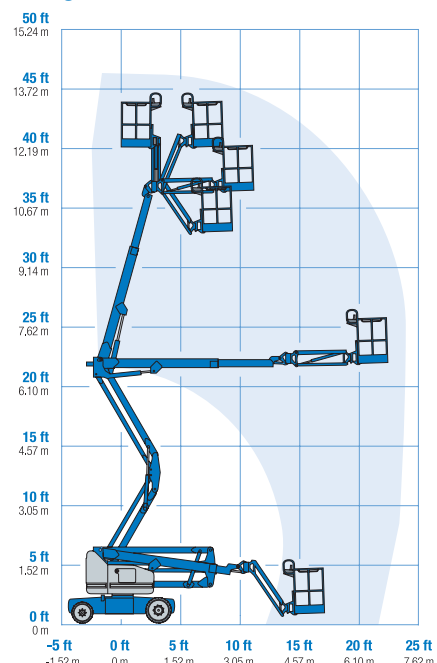

Jib range of motion Z-40/23N RJ

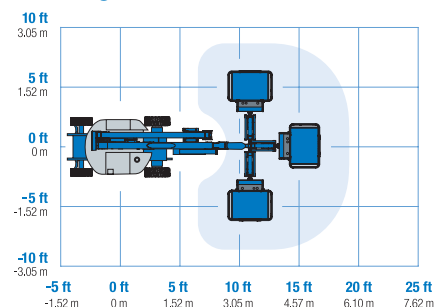

Genie® Z®-40/23N & Z-40/23N RJ

SKU: Standard Model

- **Z40N0001AE0002:** Z-40/23N with Jib, DC Power, 2WD
- **Z40NRJ01AE0003:** Z-40/23N RJ, DC Power, 2WD
- **Z40NRJ01AF0004:** Z-40/23N RJ, DC Power, Swing gate, 2WD

* Build to Order

Option availability		S	S+	BtO
Power	Standard FLA flooded lead acid battery	✓	✓	✓
	AGM Maintenance-free batteries		○	○
	Power Inverter, 800W, 120V AC, 60Hz		○	○
	Low voltage interrupt (LVI) with battery charge indicator (BCI)	✓	✓	✓
Platform	3ft 10in/1.17m steel platform	✓	✓	✓
	4ft 8in/1.42m steel platform (not available on RJ)	✓	✓	✓
	Air line to platform			○
	Control box covers		○	○
	Lift Guard Half Mesh panels with swing gate			○
	Light Package: drive and work lights		○	○
	Platform auxiliary top rail			○
	Platform swing gate			○
	AC Power cord to platform	✓	✓	✓
	Drive enable system	✓	✓	✓
	Horn	✓	✓	✓
	Lift Guard Contact Alarm	✓	✓	✓
	Platform load sense system	✓	✓	✓
	Proportional controls	✓	✓	✓
	Self-leveling platform	✓	✓	✓
Travel alarm package: flashing beacons, descent, travel and tilt alarms	✓	✓	✓	
Chassis	Lift Connect Telematics	✓	✓	✓
	Lift Connect with Access Manager upgrade		○	○
	Biodegradable hydraulic oil			○
	Cold weather hydraulic oil			○
	Fire resistant hydraulic oil			○
	Hostile environment kit			○
	Chassis tilt drive function cut-out	✓	✓	✓
	Dual parallelogram lift linkage	✓	✓	✓
	Electric brake release	✓	✓	✓
	Hour meter	✓	✓	✓
On-board diagnostic system	✓	✓	✓	
Sealed AC electric drive motors	✓	✓	✓	
Solid, non-marking tires	✓	✓	✓	

- S Standard
- S+ Standard +
- BtO Build to Order
- ✓ Standard Features
- Options



Efficient Electric Drive System



Narrow Access



Rotating Jib



Genie Genuine Accessories⁽¹⁾

- Lift Tools Productivity Tools
- Lift Connect Telematics
- Tech Pro Link Handheld Device

(1) More accessories available from Genie Genuine Parts.

Product specifications are subject to change without notice or obligation. Photographs and/or drawings herein are for illustrative purposes only. Refer to the appropriate Operator's Manual for instructions on proper equipment use. Failure to follow instructions in the Operator's Manual may result in serious injury or death. The only warranty applicable to our equipment is the standard written warranty applicable to the particular product and sale and we make no other warranty, express or implied. Products and services listed may be trademarks, service marks or trade names of Terex Corporation and/or their subsidiaries in the USA and many other countries. Terex, Genie, Quality By Design, Xtra Capacity, Lift Power, Lift Guard, Lift Tools, Lift Connect and Tech Pro Link are registered trademarks of Terex Corporation or its subsidiaries.

Genie® Z[®]-34/22 DC

Specifications

Models	Z-34/22 DC	
Measurements	US	Metric
Working height max. ⁽¹⁾	40 ft 6 in	12.52 m
Platform height max.	34 ft 6 in	10.52 m
Horizontal reach max.	22 ft 3 in	6.78 m
Up and over clearance max.	15 ft	4.57 m
A Platform length	2 ft 6 in	0.76 m
B Platform width	4 ft 8 in	1.42 m
C Height - stowed (tires)	6 ft 7 in	2.00 m
D Length - stowed (tires)	18 ft 6 in	5.64 m
E Storage height	7 ft 5 in	2.26 m
F Storage length	13 ft 5 in	4.08 m
G Width	5 ft 8 in	1.73 m
H Wheelbase	6 ft 2 in	1.88 m
I Ground clearance - center	6 in	0.15 m

Productivity

Lift capacity max. - unrestricted	500 lb	227 kg
Platform rotation	180°	180°
Jib length	4 ft	1.22 m
Vertical jib rotation	139°	139°
Turntable rotation	355°	355°
Turntable tailswing	0 in	0 cm
Drive speed - stowed ⁽²⁾	4.0 mph	6.4 km/h
Drive speed - raised	0.68 mph	1.1 km/h
Gradeability - stowed ⁽²⁾	30%	30%
Tilt sensor activation (front to back/side to side)	2.5° - 4.5° / 4.5°	2.5° - 4.5° / 4.5°
Turning radius - inside/outside	5 ft 9 in / 13 ft 1 in	1.75 m / 4.0 m
Tires (solid, non-marking)	9×14.5 in	23×37 cm

Power

Power	48V DC (8×6V 315Ah)	48V DC (8×6V 315Ah)
Auxiliary power unit	24V DC	24V DC
Hydraulic tank capacity	4 gal	15.1 L

Weight⁽³⁾ and Floor Loading⁽⁴⁾

Weight (tires)	11,420 lb	5,180 kg
Tire contact pressure	100 psi	689 kPa
Occupied floor pressure (tires)	239 psf	11.44 kPa

Sound and Vibration Levels

Sound Pressure level (ground workstation)	< 70 dBA	< 70 dBA
Sound Pressure level (platform workstation)	< 70 dBA	< 70 dBA
Vibrations	8 ft 2 in/s ²	2.5 m/s ²

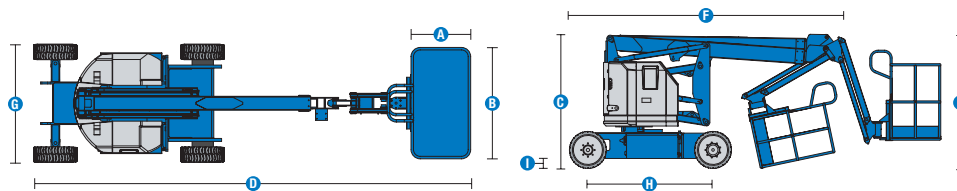

Range of motion Z-34/22 DC

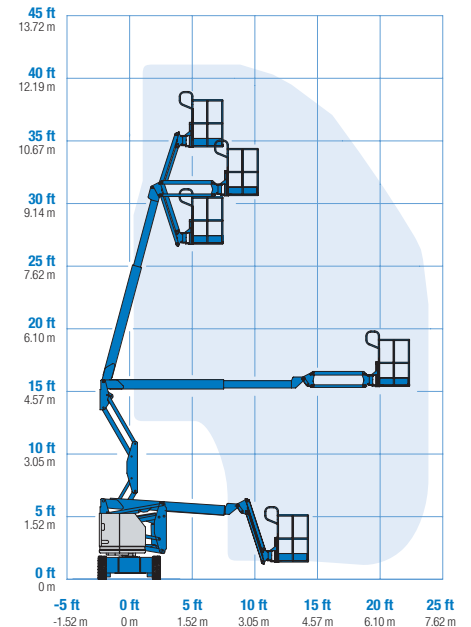

(1) The metric equivalent of working height adds 2m to platform height. The imperial equivalent adds 6ft to platform height.

(2) Gradeability applies to driving on slopes and may vary depending on options and machine configurations. See operator's manual for details regarding slope ratings.

(3) Weight refers to standard configuration and may vary depending on options and/or country standards.

(4) Floor loading information is approximate and may vary depending on options and machine configurations. It should be used only with adequate safety factors.

Genie® Z®-34/22 DC

SKU: Standard Model

- **Z34DC001AE0001:** Z-34/22 DC, DC Power, 2WD

* Build to Order

Option availability		S	S+	BtO
Power	Standard FLA flooded lead acid battery	✓	✓	✓
	AGM Maintenance-free batteries		○	○
	Battery charge indicator (BCI)			○
	Low voltage interrupt (LVI) with battery charge indicator (BCI)			○
	Power Inverter, 800W, 120V AC, 60Hz		○	○
Platform	3ft 10in/1.17m steel platform			○
	4ft 8in/1.42m steel platform	✓	✓	✓
	Air line to platform			○
	Aircraft protection kit			○
	Control box covers		○	○
	Lift Guard Half Mesh panels with swing gate			○
	Light Package: drive and work lights		○	○
	Platform auxiliary top rail			○
	Platform swing gate			○
	4ft/1.2m Jib	✓	✓	✓
	AC Power cord to platform	✓	✓	✓
	Drive enable system	✓	✓	✓
	Horn	✓	✓	✓
	Lift Guard Contact Alarm	✓	✓	✓
	Platform load sense system	✓	✓	✓
	Proportional controls	✓	✓	✓
	Self-leveling platform	✓	✓	✓
Travel alarm package: flashing beacons, descent, travel and tilt alarms	✓	✓	✓	
Chassis	Lift Connect Telematics	✓	✓	✓
	Lift Connect with Access Manager upgrade		○	○
	Biodegradable hydraulic oil			○
	Cold weather hydraulic oil			○
	Fire resistant hydraulic oil			○
	Industrial, foam-filled non-marking tires			○
	Industrial, foam-filled tires	✓	✓	✓
	Industrial, foam-filled, non-marking tires		○	○
	Hostile environment kit			○
	Chassis tilt drive function cut-out	✓	✓	✓
Dual parallelogram lift linkage	✓	✓	✓	
Hour meter	✓	✓	✓	

- S Standard
- S+ Standard +
- BtO Build to Order
- ✓ Standard Features
- Options



Quiet Operation



Zero Tailswing



Dual Parallel Linkage



Genie Genuine Accessories⁽¹⁾

- Lift Tools Productivity Tools
- Lift Connect Telematics
- Tech Pro Link Handheld Device

(1) More accessories available from Genie Genuine Parts.

Product specifications are subject to change without notice or obligation. Photographs and/or drawings herein are for illustrative purposes only. Refer to the appropriate Operator's Manual for instructions on proper equipment use. Failure to follow instructions in the Operator's Manual may result in serious injury or death. The only warranty applicable to our equipment is the standard written warranty applicable to the particular product and sale and we make no other warranty, express or implied. Products and services listed may be trademarks, service marks or trade names of Terex Corporation and/or their subsidiaries in the USA and many other countries. Terex, Genie, Quality By Design, Xtra Capacity, Lift Power, Lift Guard, Lift Tools, Lift Connect and Tech Pro Link are registered trademarks of Terex Corporation or its subsidiaries.

Genie® Z®-45/25J DC

Specifications

Models	Z-45/25J DC	
Measurements	US	Metric
Working height max.(1)	51 ft 9 in	15.94 m
Platform height max.	45 ft 9 in	13.94 m
Horizontal reach max.	25 ft 1 in	7.65 m
Up and over clearance max.	23 ft 9 in	7.24 m
A Platform length	2 ft 6 in	0.76 m
B Platform width	6 ft	1.83 m
C Height - stowed	6 ft 7 in	2.00 m
D Length - stowed	22 ft 5 in	6.83 m
E Width	5 ft 10.25 in	1.79 m
F Wheelbase	6 ft 8 in	2.03 m
G Ground clearance - center	9.5 in	0.24 m

Productivity

Lift capacity max. - unrestricted	500 lb	227 kg
Platform rotation	160°	
Jib length	5 ft	1.52 m
Vertical jib rotation	135°	
Turntable rotation	355°	
Turntable tailswing	0 in	0 cm
Drive speed - stowed ⁽²⁾	3.0 mph	4.8 km/h
Drive speed - raised	0.61 mph	1.0 km/h
Gradeability - stowed ⁽²⁾	30%	
Tilt sensor activation (front to back/side to side)	2.5° - 4.5° / 4.5°	
Turning radius - inside/outside	6 ft/14 ft	1.8 m/4.27 m
Tires (solid, non-marking)	9×14.5 in	0.23×0.37 m

Power

Power	48V DC (8×6V 350Ah)	
Auxiliary power unit	24V DC	
Hydraulic tank capacity	8 gal	30.3 L

Weight(3) and Floor Loading(4)

Weight	16,315 lb	7,400 kg
Tire contact pressure	100 psi	689 kPa
Occupied floor pressure (tires)	315 psf	15.08 kPa

Sound and Vibration Levels

Sound Pressure level (ground workstation)	< 70 dBA
Sound Pressure level (platform workstation)	< 70 dBA
Vibrations	8 ft 2 in/s ² 2.5 m/s ²

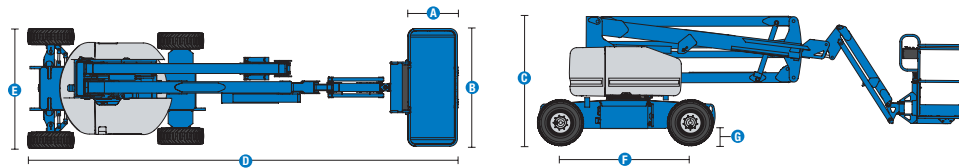

Range of motion Z-45/25J DC

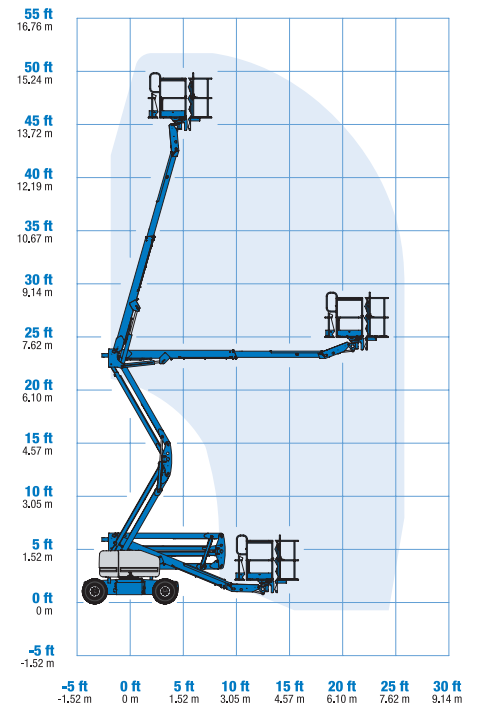

(1) The metric equivalent of working height adds 2m to platform height. The imperial equivalent adds 6ft to platform height.

(2) Gradeability applies to driving on slopes and may vary depending on options and machine configurations. See operator's manual for details regarding slope ratings.

(3) Weight refers to standard configuration and may vary depending on options and/or country standards.

(4) Floor loading information is approximate and may vary depending on options and machine configurations. It should be used only with adequate safety factors.

Genie® Z[®]-45/25J DC

SKU: Standard Model

- **Z45JDC01AE0005:** Z-45/25J DC, DC Power, 2WD

* Build to Order

Option availability		S	S+	BtO
Power	Standard FLA flooded lead acid battery	✓	✓	✓
	AGM Maintenance-free batteries		○	○
	Battery charge indicator (BCI)	✓	✓	✓
	Low voltage interrupt (LVI) with battery charge indicator (BCI)	✓	✓	✓
	Power Inverter, 800W, 120V AC, 60Hz		○	○
Platform	3ft 10in/1.17m steel platform			○
	6ft/1.83m dual-entry platform with side swing gate	✓	✓	✓
	Air line to platform			○
	Control box covers		○	○
	Lift Guard Half Mesh panels			○
	Light Package: drive and work lights		○	○
	Platform auxiliary top rail			○
	AC Power cord to platform	✓	✓	✓
	Alarm package: flashing beacons, descent, travel and tilt alarms	✓	✓	✓
	Drive enable system	✓	✓	✓
	Horn	✓	✓	✓
	LCD display	✓	✓	✓
	Lift Guard Contact Alarm	✓	✓	✓
	Lift Tools Work Tray	✓	✓	✓
	Platform load sense system	✓	✓	✓
	Proportional controls	✓	✓	✓
	Self-leveling platform	✓	✓	✓
Chassis	Lift Connect Telematics		○	○
	Telematics-ready	✓	✓	✓
	Lift Connect with Access Manager upgrade		○	○
	Biodegradable hydraulic oil			○
	Biodegradable hydraulic oil			○
	Cold weather hydraulic oil			○
	Fire resistant hydraulic oil (45/25J DC)			○
	Industrial, foam-filled tires	✓	✓	✓
	Industrial, foam-filled, non-marking tires		○	○
	Hostile environment kit			○
	Tow package			○
	Chassis tilt drive function cut-out	✓	✓	✓
	Chassis tilt lift function cut-out	✓	✓	✓
	Dual parallelogram lift linkage	✓	✓	✓
Hour meter	✓	✓	✓	
Zero tail swing	✓	✓	✓	

- S Standard
- S+ Standard +
- BtO Build to Order
- ✓ Standard Features
- Options



Quiet Operation



Zero Tailswing



Dual Parallel Linkage



Genie Genuine Accessories⁽¹⁾

- Lift Tools Productivity Tools
- Lift Connect Telematics
- Tech Pro Link Handheld Device

(1) More accessories available from Genie Genuine Parts.

Product specifications are subject to change without notice or obligation. Photographs and/or drawings herein are for illustrative purposes only. Refer to the appropriate Operator's Manual for instructions on proper equipment use. Failure to follow instructions in the Operator's Manual may result in serious injury or death. The only warranty applicable to our equipment is the standard written warranty applicable to the particular product and sale and we make no other warranty, express or implied. Products and services listed may be trademarks, service marks or trade names of Terex Corporation and/or their subsidiaries in the USA and many other countries. Terex, Genie, Quality By Design, Xtra Capacity, Lift Power, Lift Guard, Lift Tools, Lift Connect and Tech Pro Link are registered trademarks of Terex Corporation or its subsidiaries.

Genie® Z®-45 DC & Z-45 FE

Specifications

Models	Z-45 DC & Z-45 FE	
Measurements	US	Metric
Working height max. ⁽¹⁾	51 ft 8 in	15.92 m
Platform height max.	45 ft 8 in	13.92 m
Horizontal reach max.	22 ft 9 in	6.94 m
Up and over clearance max.	24 ft 7 in	7.50 m
A Platform length	2 ft 6 in	0.76 m
B Platform width	6 ft	1.83 m
C Height - stowed	7 ft 6 in	2.29 m
D Length - stowed	20 ft 1 in	6.11 m
E Width	7 ft 6 in	2.29 m
F Wheelbase	6 ft 8 in	2.03 m
G Ground clearance - center	1 ft 4 in	0.41 m

Productivity

Lift capacity max. - unrestricted	660 lb	300 kg
Platform rotation		160°
Jib length	5 ft	1.52 m
Vertical jib rotation		135°
Turntable rotation		355°
Turntable tailswing	1 ft 3 in	0.37 m
Drive speed - stowed ⁽²⁾	4.5 mph	7.24 km/h
Drive speed - raised	0.31 mph	0.50 km/h
Gradeability - stowed ⁽²⁾		45%
Tilt sensor activation (front to back/side to side)		4.5° / 4.5°
Turning radius - inside/outside	7 ft 10 in / 14 ft 1 in	2.40 m / 4.30 m
Tires		315/55 D20

Power

Drive system	34V 3-Phase AC	34V 3-Phase AC
Battery Pack, DC	48V DC (8×6V), 390Ah, FLA	
Battery Pack, FE	48V DC (8×6V), 370Ah, AGM	
AC generator, FE	Diesel	
Auxiliary power unit	12V DC	
Hydraulic tank capacity	10.5 gal	40 L
Fuel tank capacity	17 gal	64 L

Weight⁽³⁾ and Floor Loading⁽⁴⁾

Weight, DC	14,064 lb	6,379 kg
Weight, FE	14,460 lb	6,559 kg
Tire contact pressure	70 psi	482 kPa
Occupied floor pressure (tires)	206 psf	9.88 kPa

Sound and Vibration Levels

Sound Pressure level (ground workstation)	< 70 dBA (DC) / 88 dBA (FE)
Sound Pressure level (platform workstation)	< 70 dBA (DC) / 82 dBA (FE)
Vibrations	1.81 ft/s ² 0.55 m/s ²

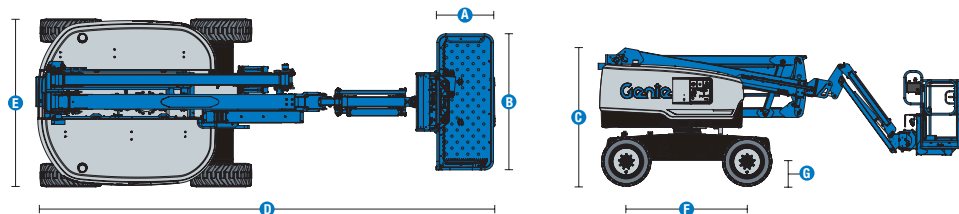

(1) The metric equivalent of working height adds 2m to platform height. The imperial equivalent adds 6ft to platform height.

(2) Gradeability applies to driving on slopes and may vary depending on options and machine configurations. See operator's manual for details regarding slope ratings.

(3) Weight refers to standard configuration and may vary depending on options and/or country standards.

(4) Floor loading information is approximate and may vary depending on options and machine configurations. It should be used only with adequate safety factors.

Range of motion Z-45 DC & FE

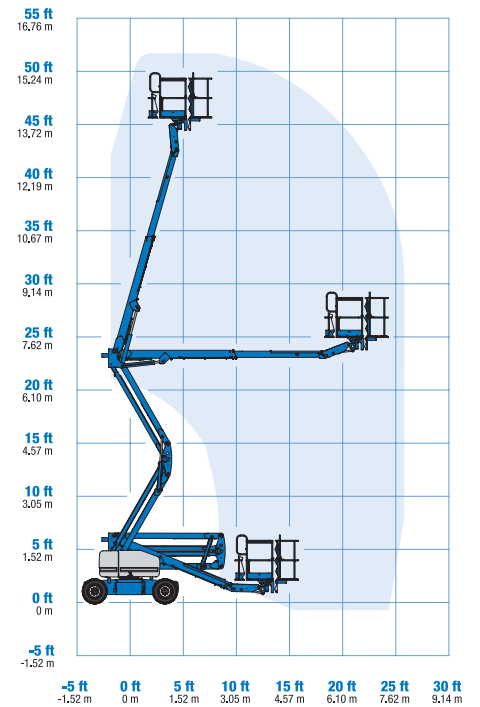

Genie® Z®-45 DC & Z-45 FE

SKU: Standard Model

- Z-45 DC, DC Power, 4WD*
- Z45FE001AE0005: Z-45 FE Hybrid, 4WD

* Build to Order

Option availability		S	S+	BtO
Power	24.8 hp, 18.5kW, Kubota D1105, Diesel, T4i/T4f, Stage IIIA/V, CN III (FE model only)	✓	✓	✓
	FLA flooded lead acid batteries (DC model only)		✓	✓
	AGM Maintenance-free batteries (Optional on DC)	✓	✓	✓
	Cold weather package			○
	Power inverter, 2kW, 120V/60Hz		○	○
	Low voltage interrupt (LVI) with battery charge indicator (BCI)	✓	✓	✓
	Platform	Dual axis joystick steering	✓	✓
Air line to platform				○
Control box covers			○	○
Lift Guard Full Mesh panels				○
Lift Guard Half Mesh panels				○
Light Package: drive and work lights			○	○
Platform auxiliary top rail				○
5ft/1.52m Jib		✓	✓	✓
6ft/1.83m dual-entry platform with side swing gate		✓	✓	✓
AC Power cord to platform		✓	✓	✓
Alarm package: flashing beacons, descent, travel and tilt alarms		✓	✓	✓
Drive enable system		✓	✓	✓
Horn		✓	✓	✓
LCD display		✓	✓	✓
Lift Guard Contact Alarm		✓	✓	✓
Lift Tools Work Tray		✓	✓	✓
Platform load sense system		✓	✓	✓
Proportional controls	✓	✓	✓	
Self-leveling platform	✓	✓	✓	
Chassis	Lift Connect Telematics		○	○
	Telematics-ready	✓	✓	✓
	Lift Connect with Access Manager upgrade		○	○
	Biodegradable hydraulic oil			○
	Cold weather hydraulic oil			○
	Fire resistant hydraulic oil			○
	Rough terrain, foam-filled tires		○	○
	Rough terrain, foam-filled, non-marking tires	✓	✓	✓
	Active oscillating axle	✓	✓	✓
	Chassis tilt drive function cut-out	✓	✓	✓
	Chassis tilt lift function cut-out	✓	✓	✓
	Dual parallelogram lift linkage	✓	✓	✓
Electric brake release	✓	✓	✓	
Hour meter	✓	✓	✓	
On-board diagnostic system	✓	✓	✓	
Sealed AC electric drive motors	✓	✓	✓	

- S Standard
- S+ Standard +
- BtO Build to Order
- ✓ Standard Features
- Options



Indoor & Outdoor Boom



Rugged Terrainability



660lb/300kg Capacity Jib



Genie Genuine Accessories⁽¹⁾

- Lift Tools Productivity Tools
- Lift Connect Telematics
- Tech Pro Link Handheld Device

(1) More accessories available from Genie Genuine Parts.

Product specifications are subject to change without notice or obligation. Photographs and/or drawings herein are for illustrative purposes only. Refer to the appropriate Operator's Manual for instructions on proper equipment use. Failure to follow instructions in the Operator's Manual may result in serious injury or death. The only warranty applicable to our equipment is the standard written warranty applicable to the particular product and sale and we make no other warranty, express or implied. Products and services listed may be trademarks, service marks or trade names of Terex Corporation and/or their subsidiaries in the USA and many other countries. Terex, Genie, Quality By Design, Xtra Capacity, Lift Power, Lift Guard, Lift Tools, Lift Connect and Tech Pro Link are registered trademarks of Terex Corporation or its subsidiaries.

Genie® Z®-60 DC & Z-60 FE

Specifications

Models	Z-60 DC & Z-60 FE	
Measurements	US	Metric
Working height max. ⁽¹⁾	65 ft 7 in	20.16 m
Platform height max.	59 ft 7 in	18.16 m
Horizontal reach max.	36 ft 7 in	11.15 m
Below ground reach	8 ft 1 in	2.46 m
Up and over clearance max.	24 ft 3 in	7.39 m
A Platform length (8 ft/6 ft)	3 ft/2 ft 6 in	0.91 m/0.76 m
B Platform width (8 ft/6 ft)	8 ft/6 ft	2.44 m/1.83 m
C Height - stowed	8 ft 4 in	2.54 m
D Length - stowed	26 ft 9 in	8.15 m
E Width	8 ft 2 in	2.49 m
F Wheelbase	8 ft 2 in	2.49 m
G Ground clearance - center	1 ft 1 in	0.33 m

Productivity

Lift capacity max. - unrestricted	500 lb	227 kg
Platform rotation	160°	
Jib length	5 ft	1.52 m
Vertical jib rotation	135°	
Turntable rotation	355°	
Drive speed - stowed ⁽²⁾	4.0 mph	6.44 km/h
Drive speed - raised	0.68 mph	1.1 km/h
Gradeability - stowed ⁽²⁾	45%	
Tilt sensor activation (front to back/side to side)	2.5° / 4.5°	
Turning radius - inside/outside	8 ft 3 in/18 ft 8 in	2.51 m/5.69 m
Tires	355/55 D625	

Power

Drive system	34V 3-Phase AC	
Battery Pack, DC	48V DC (8×6V), 390Ah, FLA	
Battery Pack, FE	48V DC (8×6V), 415Ah, AGM	48V DC (8×6V), 415Ah, AGM
AC generator, FE	Diesel	
Auxiliary power unit	12V DC	
Hydraulic tank capacity	18 gal	68.14 L
Fuel tank capacity	17 gal	64 L

Weight⁽³⁾ and Floor Loading⁽⁴⁾

Weight, DC	16,600 lb	7,530 kg
Weight, FE	17,100 lb	7,756 kg
Tire contact pressure	70 psi	483 kPa
Occupied floor pressure (tires)	180 psf	8.62 kPa

Sound and Vibration Levels

Sound Pressure level (ground workstation)	< 70 dBA (DC)/87 dBA (FE)
Sound Pressure level (platform workstation)	< 70 dBA (DC)/76 dBA (FE)
Vibrations	1.81 ft/s ² 0.55 m/s ²

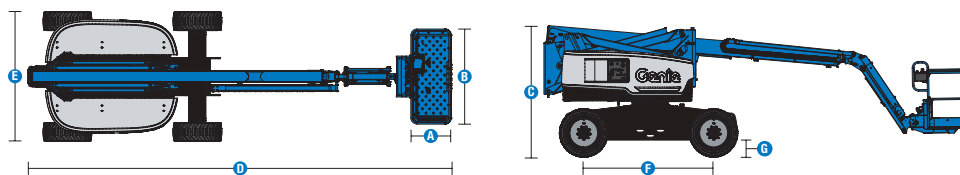

(1) The metric equivalent of working height adds 2m to platform height. The imperial equivalent adds 6ft to platform height.

(2) Gradeability applies to driving on slopes and may vary depending on options and machine configurations. See operator's manual for details regarding slope ratings.

(3) Weight refers to standard configuration and may vary depending on options and/or country standards.

(4) Floor loading information is approximate and may vary depending on options and machine configurations. It should be used only with adequate safety factors.

Range of motion Z-60 DC & FE

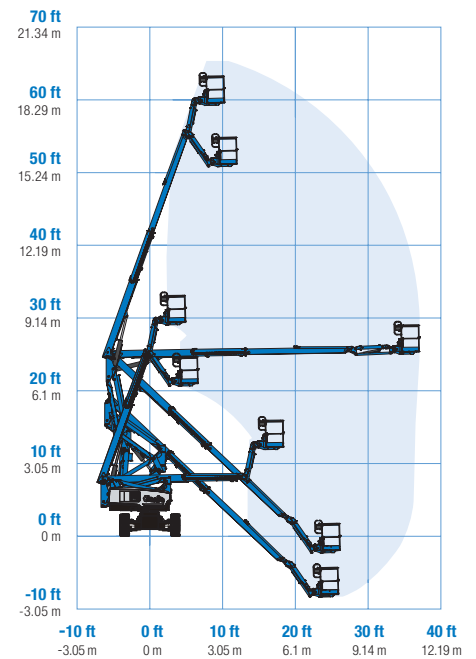

Genie® Z®-60 DC & Z-60 FE

SKU: Standard Model

- Z-60 DC, DC Power, 4WD*
- **Z60FE001AE0002**: Z-60 FE Hybrid, 4WD

* Build to Order

Option availability		S	S+	BtO	
Power	24.8 hp, 18.5kW, Kubota D1105, Diesel, T4i/T4f, Stage IIIA/V, CN III (FE model only)	✓	✓	✓	
	FLA flooded lead acid batteries (DC model only)		✓	✓	
	AGM Maintenance-free batteries (Optional on DC)	✓	✓	✓	
	Cold weather package			○	
	Power inverter, 2kW, 120V/60Hz		○	○	
	Low voltage interrupt (LVI) with battery charge indicator (BCI)	✓	✓	✓	
	Platform	6ft/1.83m dual-entry platform with side swing gate	✓	✓	✓
8ft/2.44m dual-entry platform with side swing gate		✓	✓	✓	
Dual axis joystick steering		✓	✓	✓	
Thumb rocker steering				○	
Air line to platform				○	
Control box covers			○	○	
Lift Guard Full Mesh panels				○	
Lift Guard Half Mesh panels				○	
Light Package: drive and work lights			○	○	
Platform auxiliary top rail				○	
5ft/1.52m Jib		✓	✓	✓	
AC Power cord to platform		✓	✓	✓	
Alarm package: flashing beacons, descent, travel and tilt alarms		✓	✓	✓	
Drive enable system		✓	✓	✓	
Horn		✓	✓	✓	
LCD display		✓	✓	✓	
Lift Guard Contact Alarm		✓	✓	✓	
Lift Tools Work Tray		✓	✓	✓	
Platform load sense system		✓	✓	✓	
Proportional controls		✓	✓	✓	
Self-leveling platform		✓	✓	✓	
Chassis		Lift Connect Telematics		○	○
		Telematics-ready	✓	✓	✓
	Lift Connect with Access Manager upgrade		○	○	
	Biodegradable hydraulic oil			○	
	Cold weather hydraulic oil			○	
	Fire resistant hydraulic oil			○	
	Rough terrain, foam-filled, non-marking tires	✓	✓	✓	
	Rough terrain, foam-filled tires		○	○	
	Hostile environment kit			○	
	Tow package			○	
	Active oscillating axle	✓	✓	✓	
	Chassis tilt drive function cut-out	✓	✓	✓	
	Chassis tilt lift function cut-out	✓	✓	✓	
	Dual parallelogram lift linkage	✓	✓	✓	
	Electric brake release	✓	✓	✓	
Hour meter	✓	✓	✓		
On-board diagnostic system	✓	✓	✓		
Sealed AC electric drive motors	✓	✓	✓		

- S Standard
- S+ Standard +
- BtO Build to Order
- ✓ Standard Features
- Options



Indoor & Outdoor Boom



Rugged Terrainability



Low Noise, Low Emissions



Genie Genuine Accessories⁽¹⁾

- Lift Tools Productivity Tools
- Lift Connect Telematics
- Tech Pro Link Handheld Device

(1) More accessories available from Genie Genuine Parts.

Product specifications are subject to change without notice or obligation. Photographs and/or drawings herein are for illustrative purposes only. Refer to the appropriate Operator's Manual for instructions on proper equipment use. Failure to follow instructions in the Operator's Manual may result in serious injury or death. The only warranty applicable to our equipment is the standard written warranty applicable to the particular product and sale and we make no other warranty, express or implied. Products and services listed may be trademarks, service marks or trade names of Terex Corporation and/or their subsidiaries in the USA and many other countries. Terex, Genie, Quality By Design, Xtra Capacity, Lift Power, Lift Guard, Lift Tools, Lift Connect and Tech Pro Link are registered trademarks of Terex Corporation or its subsidiaries.

Genie® Z®-34/22 IC

Specifications

Models	Z-34/22 IC	
Measurements	US	Metric
Working height max. ⁽¹⁾	40 ft 7 in	12.54 m
Platform height max.	34 ft 7 in	10.54 m
Horizontal reach max.	22 ft 3 in	6.78 m
Up and over clearance max.	15 ft 1 in	4.60 m
A Platform length	2 ft 6 in	0.76 m
B Platform width	4 ft 8 in	1.42 m
C Height - stowed	6 ft 9 in	2.06 m
D Length - stowed	18 ft 7 in	5.66 m
E Storage height	7 ft 6 in	2.29 m
F Storage length	13 ft 6 in	4.11 m
G Width (Tires)	6 ft 1 in	1.85 m
H Wheelbase	6 ft 2 in	1.88 m
I Ground clearance - center	6.5 in	0.17 m

Productivity

Lift capacity max. - unrestricted	500 lb	227 kg
Platform rotation	180°	
Jib length	4 ft	1.22 m
Vertical jib rotation	139°	
Turntable rotation	355°	
Turntable tailswing	0 in	0 cm
Drive speed - stowed ⁽²⁾	3.0 mph	4.8 km/h
Drive speed - raised	0.68 mph	1.1 km/h
Gradeability - stowed ⁽²⁾	45%	
Tilt sensor activation (front to back/side to side)	2.5° - 4.5° / 4.5°	
Turning radius - inside/outside	5 ft 11 in / 13 ft 6 in	1.80 m / 4.11 m
Tires (solid, non-marking)	10×16.5 in	25×42 cm

Power

Power	Diesel	
Auxiliary power unit	12V DC	
Hydraulic tank capacity	19 gal	71.9 L
Fuel tank capacity	9 gal	34 L

Weight⁽³⁾ and Floor Loading⁽⁴⁾

Weight	11,010 lb	4,994 kg
Tire contact pressure	45 psi	310 kPa
Occupied floor pressure (tires)	221 psf	10.58 kPa

Sound and Vibration Levels

Sound Pressure level (ground workstation)	81 dBA	
Sound Pressure level (platform workstation)	80 dBA	
Vibrations	8 ft 2 in/s ²	2.5 m/s ²

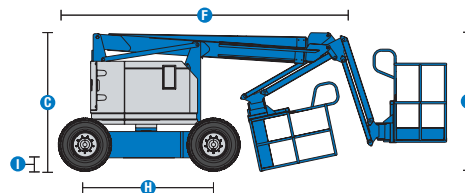
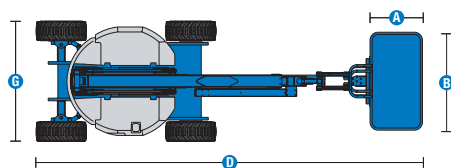

Range of motion Z-34/22 IC

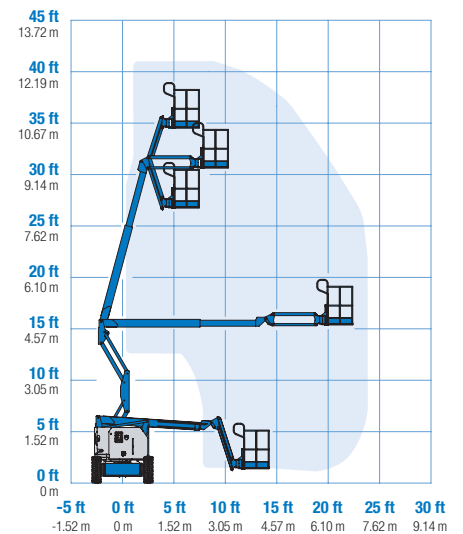

(1) The metric equivalent of working height adds 2m to platform height. The imperial equivalent adds 6ft to platform height.

(2) Gradeability applies to driving on slopes and may vary depending on options and machine configurations. See operator's manual for details regarding slope ratings.

(3) Weight refers to standard configuration and may vary depending on options and/or country standards.

(4) Floor loading information is approximate and may vary depending on options and machine configurations. It should be used only with adequate safety factors.

Genie® Z®-34/22 IC

SKU: Standard Model

- **Z34IC001A30002:** Z-34/22 IC, 4WD
- **Z34IC001A30003:** Z-34/22 IC, Cold weather package, 4WD
- **Z34IC001AD0001:** Z-34/22 IC, 28 hp, GM .998L, Gas/LPG, Gauge package, 4WD

* Build to Order

Option availability	S	S+	BtO
Power			
24.8 hp, 18.5kW, Kubota D1105, Diesel, T4i/T4f, Stage IIIA/IV, CN IV	✓	✓	✓
28 hp, 21.6kW, GM .998L, Gas/LPG			○
Cold weather package			○
Engine gauge package			○
LPG tank 33.5 lb		○	○
Platform			
3ft 10in/1.17m steel platform			○
4ft 8in/1.42m steel platform	✓	✓	✓
Air line to platform			○
Control box covers		○	○
Lift Guard Half Mesh panels with swing gate			○
Lift Guard Half Mesh panels with swing gate			○
Light Package: drive and work lights		○	○
Platform auxiliary top rail			○
Platform swing gate			○
2.2kW AC Generator, 110V/60Hz			○
2.2kW AC Generator, 220V/50Hz			○
4ft/1.2m Jib	✓	✓	✓
AC Power cord to platform	✓	✓	✓
Alarm package: flashing beacons, descent, travel and tilt alarms	✓	✓	✓
Drive enable system	✓	✓	✓
Horn	✓	✓	✓
Lift Guard Contact Alarm	✓	✓	✓
Platform load sense system	✓	✓	✓
Proportional controls	✓	✓	✓
Self-leveling platform	✓	✓	✓
Chassis			
Lift Connect Telematics		○	○
Telematics-ready	✓	✓	✓
Lift Connect with Access Manager upgrade		○	○
Biodegradable hydraulic oil			○
Cold weather hydraulic oil			○
Fire resistant hydraulic oil			○
Industrial, foam-filled non-marking tires			○
Rough terrain, foam-filled tires	✓	✓	✓
Hostile environment kit			○
2 speed wheel motors	✓	✓	✓
2 wheel steering	✓	✓	✓
Chassis tilt drive function cut-out	✓	✓	✓
Chassis tilt lift function cut-out	✓	✓	✓
Dual parallelogram lift linkage	✓	✓	✓
Hour meter	✓	✓	✓
Hydrostatic drive system	✓	✓	✓
Solid, non-marking tires	✓	✓	✓

- S Standard
- S+ Standard +
- BtO Build to Order
- ✓ Standard Features
- Options



Zero Tailswing



4W Drive



Dual Parallel Linkage



Genie Genuine Accessories⁽¹⁾

- Lift Tools Productivity Tools
- Lift Connect Telematics
- Tech Pro Link Handheld Device

(1) More accessories available from Genie Genuine Parts.

Product specifications are subject to change without notice or obligation. Photographs and/or drawings herein are for illustrative purposes only. Refer to the appropriate Operator's Manual for instructions on proper equipment use. Failure to follow instructions in the Operator's Manual may result in serious injury or death. The only warranty applicable to our equipment is the standard written warranty applicable to the particular product and sale and we make no other warranty, express or implied. Products and services listed may be trademarks, service marks or trade names of Terex Corporation and/or their subsidiaries in the USA and many other countries. Terex, Genie, Quality By Design, Xtra Capacity, Lift Power, Lift Guard, Lift Tools, Lift Connect and Tech Pro Link are registered trademarks of Terex Corporation or its subsidiaries.

Genie® Z®-45 XC™ & Z-45 HF

Specifications

Models	Z-45 XC		Z-45 HF	
Measurements	US	Metric	US	Metric
Working height max. ⁽¹⁾	51 ft 6 in	15.86 m	51 ft 6 in	15.86 m
Platform height max.	45 ft 6 in	13.86 m	45 ft 6 in	13.86 m
Horizontal reach max.	24 ft 9 in	7.55 m	24 ft 9 in	7.55 m
Up and over clearance max.	24 ft 5 in	7.44 m	24 ft 5 in	7.44 m
A Platform length	2 ft 6 in	0.76 m	2 ft 6 in	0.76 m
B Platform width	6 ft	1.83 m	6 ft	1.83 m
C Height - stowed	7 ft 4 in	2.25 m	7 ft 4 in	2.25 m
D Length - stowed	21 ft 10 in	6.65 m	21 ft 10 in	6.65 m
E Width	7 ft 6 in	2.29 m	8 ft 5 in	2.57 m
F Wheelbase	6 ft 8 in	2.03 m	6 ft 8 in	2.03 m
G Ground clearance - center	14.8 in	0.37 m	14.8 in	0.37 m

Productivity

Lift capacity max. - unrestricted	660 lb	300 kg	600 lb	272 kg
Lift capacity max. - restricted	1,000 lb	454 kg		
Platform rotation	160°		160°	
Jib length	5 ft	1.52 m	5 ft	1.52 m
Vertical jib rotation	133°		133°	
Turntable rotation	355°		355°	
Turntable tailswing	0 in	0 cm	0 in	0 cm
Drive speed - stowed ⁽²⁾	4.5 mph	7.24 km/h	4.5 mph	7.24 km/h
Drive speed - raised	0.61 mph	0.98 km/h	0.61 mph	0.98 km/h
Gradeability - stowed ⁽²⁾	45 %		45 %	
Tilt sensor activation (front to back/side to side)	4.5°/4.5°		4.5°/4.5°	
Turning radius - inside/outside	5 ft 6 in/14 ft 9 in	1.68 m/4.50 m	5 ft 6 in/14 ft 9 in	1.68 m/4.50 m
Tires (foam-filled)	315/55 D20			

Power

Power	Diesel		Diesel	
Auxiliary power unit	12V DC		12V DC	
Hydraulic tank capacity	22 gal	83 L	22 gal	83 L
Fuel tank capacity	17 gal	64 L	17 gal	64 L

Weight⁽³⁾ and Floor Loading⁽⁴⁾

Weight	16,360 lb	7,421 kg	16,050 lb	7,280 kg
Tire contact pressure	80 psi	552 kPa	38 psi	262 kPa
Occupied floor pressure (tires)	231 psf	11.08 kPa	229 psf	10.94 kPa

Sound and Vibration Levels

Sound Pressure level (ground workstation)	87 dBA		87 dBA	
Sound Pressure level (platform workstation)	82 dBA		82 dBA	
Vibrations	8 ft 2 in/s ²	2.5 m/s ²	8 ft 2 in/s ²	2.5 m/s ²

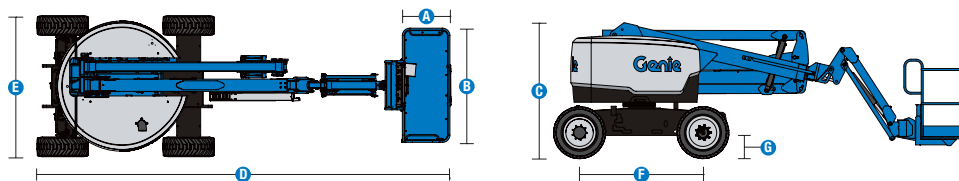

(1) The metric equivalent of working height adds 2m to platform height. The imperial equivalent adds 6ft to platform height.

(2) Gradeability applies to driving on slopes and may vary depending on options and machine configurations. See operator's manual for details regarding slope ratings.

(3) Weight refers to standard configuration and may vary depending on options and/or country standards.

(4) Floor loading information is approximate and may vary depending on options and machine configurations. It should be used only with adequate safety factors.

Range of motion Z-45 XC

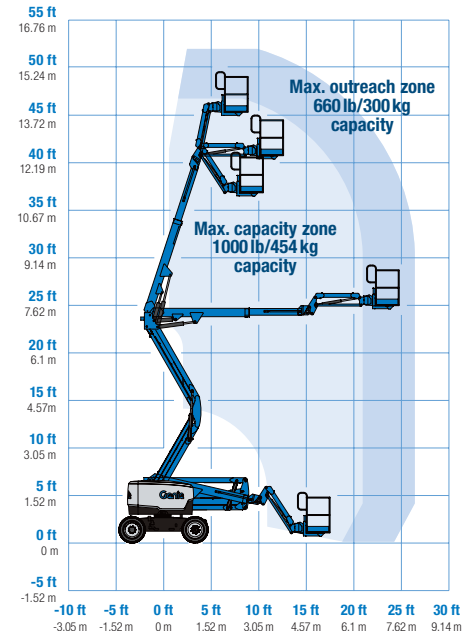

Genie® Z®-45 XC™ & Z-45 HF

SKU: Standard Model

- **Z45XC001AF0001:** Z-45 XC, 4WD
- **Z45XC001AF0006:** Z-45 XC, Lift Power 3kW Welder Ready, 4WD
- **Z45XC001AF0007:** Z-45 XC, Lift Power 12kW Welder Ready, 4WD

* Build to Order

Option availability	S	S+	BtO
Power			
49 hp, 37 kW, Deutz D2.9L, Diesel, T4f	✓	✓	✓
49 hp, 36 kW, Perkins 404F-E22T, Turbo Diesel, T4f			○
60 hp, 44.7 kW, Ford MSG425 gas/LPG Dual Fuel			○
Cold weather package			○
LPG tank 33.5 lb		○	○
Positive air shutdown system			○
Anti-restart engine protection	✓	✓	✓
Auto engine fault shutdown	✓	✓	✓
Platform			
6ft/1.83m dual-entry platform with side swing gate	✓	✓	✓
Dual axis joystick steering	✓	✓	✓
Thumb rocker steering			○
Air line to platform			○
Control box covers		○	○
Lift Guard Full Mesh panels			○
Lift Guard Half Mesh panels			○
Light Package: drive and work lights		○	○
Platform auxiliary top rail			○
Lift Power 3kW AC Generator, 110V/60Hz			○
Lift Power 3kW AC Generator, 220V/50Hz			○
Lift Power 12kW Welder ready			○
600lb/272kg load capacity with auto envelope control (HF model)	✓	✓	✓
660lb/300kg & 1000lb/454kg dual load with auto envelope control	✓	✓	✓
AC Power cord to platform	✓	✓	✓
Alarm package: flashing beacons, descent, travel and tilt alarms	✓	✓	✓
Drive enable system	✓	✓	✓
Horn	✓	✓	✓
Lift Guard Contact Alarm	✓	✓	✓
Lift Tools Work Tray	✓	✓	✓
Platform load sense system	✓	✓	✓
Proportional controls	✓	✓	✓
Self-leveling platform	✓	✓	✓
Chassis			
Lift Connect Telematics		○	○
Telematics-ready	✓	✓	✓
Lift Connect with Access Manager upgrade		○	○
Biodegradable hydraulic oil			○
Cold weather hydraulic oil			○
Fire resistant hydraulic oil			○
High floatation, air-filled tires			○
Rough terrain, foam-filled tires	✓	✓	✓
Rough terrain, foam-filled, non-marking tires		○	○
Hostile environment kit			○
Tow package			○
2 speed wheel motors	✓	✓	✓
Active oscillating axle	✓	✓	✓
Chassis tilt drive function cut-out	✓	✓	✓
Chassis tilt lift function cut-out	✓	✓	✓
Dual parallelogram lift linkage	✓	✓	✓
Hour meter	✓	✓	✓
Hydraulic oil cooler	✓	✓	✓

Positive air shutdown Deutz engines only

- S Standard
- S+ Standard +
- BtO Build to Order
- ✓ Standard Features
- Options



Zero Tailswing



Rugged Terrainability



Zero-Load Calibration



Genie Genuine Accessories⁽¹⁾

- Lift Tools Productivity Tools
- Lift Connect Telematics
- Tech Pro Link Handheld Device

(1) More accessories available from Genie Genuine Parts.

Product specifications are subject to change without notice or obligation. Photographs and/or drawings herein are for illustrative purposes only. Refer to the appropriate Operator's Manual for instructions on proper equipment use. Failure to follow instructions in the Operator's Manual may result in serious injury or death. The only warranty applicable to our equipment is the standard written warranty applicable to the particular product and sale and we make no other warranty, express or implied. Products and services listed may be trademarks, service marks or trade names of Terex Corporation and/or their subsidiaries in the USA and many other countries. Terex, Genie, Quality By Design, Xtra Capacity, Lift Power, Lift Guard, Lift Tools, Lift Connect and Tech Pro Link are registered trademarks of Terex Corporation or its subsidiaries.

Genie® Z®-62/40 & Z-62/40 TraX™

Specifications

Models	Z-62/40 & Z-62/40 TraX	
Measurements	US	Metric
Working height max.(1)	67 ft 11 in	20.87 m
Working height max. (TraX)(1)	68 ft 1 in	20.92 m
Platform height max.	61 ft 11 in	18.87 m
Platform height max. (TraX)	62 ft 1 in	18.92 m
Horizontal reach max.	40 ft 9 in	12.42 m
Below ground reach	8 ft 1 in	2.46 m
Up and over clearance max.	25 ft 7 in	7.8 m
A Platform length (8 ft/6 ft)	3 ft/2 ft 6	0.91 m/0.76 m
B Platform width (8 ft/6 ft)	8 ft/6 ft	2.44 m/1.83 m
C Height - stowed (tires)	8 ft 4 in	2.54 m
C Height - stowed (TraX)	8 ft 11 in	2.72 m
C Height - storage/transport (jib tucked under - Tires/TraX)	9 ft 6 in/9 ft 5 in	2.90 m/2.87 m
D Length - stowed (tires)	30 ft 3 in	9.22 m
D Length - stowed (TraX)	31 ft 7 in	9.63 m
D Length - storage/transport (jib tucked under) (Tires/TraX)	24 ft 5 in/25 ft 5 in	7.44 m/7.75 m
E Width	8 ft 2 in	2.49 m
E Width (TraX)	8 ft 1.6 in	2.48 m
F Wheelbase	8 ft 2 in	2.49 m
G Ground clearance - center (tires)	1 ft 3 in	0.38 m
G Ground clearance - center (TraX)	1 ft 6.6 in	0.47 m

Productivity

Lift capacity max. - unrestricted	500 lb	227 kg
Platform rotation	160°	
Jib length	5 ft	1.52 m
Vertical jib rotation	135°	
Turntable rotation	360°	
Turntable tailswing	zero	
Drive speed - stowed (tires)(2)	3.0 mph	4.8 km/h
Drive speed - stowed (TraX)	2.3 mph	3.7 km/h
Drive speed - raised (tires)	0.70 mph	1.1 km/h
Drive speed - raised (TraX)	0.70 mph	1.1 km/h
Gradeability - stowed(2)	30%	45%
Tilt sensor activation (front to back/side to side)	4.5° / 4.5°	
Turning radius - inside/outside (tires, 4WD)	4 ft 5 in/11 ft 11 in	1.30 m/3.60 m
Turning radius - inside/outside (TraX)	8 ft 0.5 in/18 ft 5 in	2.45 m/5.60 m
Tires (solid, non-marking)	355/55 D625	

Power

Power	Diesel	
Auxiliary power unit	12V DC	
Hydraulic tank capacity	35 gal	132 L
Fuel tank capacity	36 gal	136 L

Weight(3) and Floor Loading(4)

Weight, 2WS	22,160 lb	10,052 kg
Weight, 4WS	22,665 lb	10,281 kg
Weight (TraX)	26,933 lb	12,217 kg
Tire contact pressure	70 psi	483 kPa
Track contact pressure	12.5 psi	86 kPa
Occupied floor pressure (tires)	265 psf	12.71 kPa
Occupied floor pressure (TraX)	265 psf	12.71 kPa

Sound and Vibration Levels

Sound Pressure level (ground workstation)	86 dBA	
Sound Pressure level (platform workstation)	75 dBA	
Vibrations	8 ft 2 in/s ²	2.5 m/s ²

(1) The metric equivalent of working height adds 2m to platform height. The imperial equivalent adds 6ft to platform height.
 (2) Gradeability applies to driving on slopes and may vary depending on options and machine configurations. See operator's manual for details regarding slope ratings.
 (3) Weight refers to standard configuration and may vary depending on options and/or country standards.
 (4) Floor loading information is approximate and may vary depending on options and machine configurations. It should be used only with adequate safety factors.

Range of motion Z-62/40 & Z-62/40 TraX

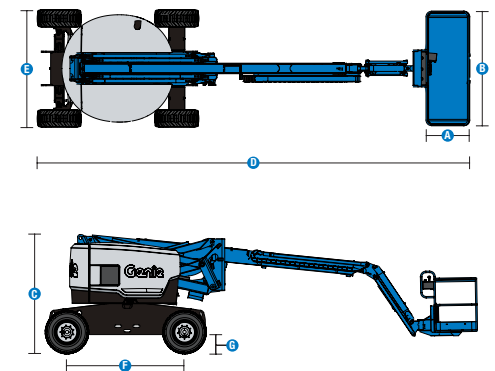
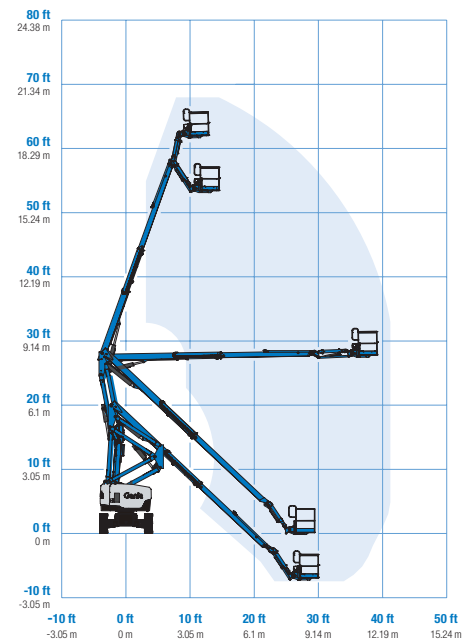

Genie® Z®-62/40 & Z-62/40 TraX™

SKU: Standard Model

- Z-62/40, 2WD*
- **Z6200001AF0003:** Z-62/40, 4WD
- **Z6200001AF0004:** Z-62/40, 12kW Welder Ready, 4WD
- **Z6200001AI0034:** Z-62/40 TraX 74 hp, Deutz Turbo Diesel

* Build to Order

Option availability		S	S+	BtO	
Power	49 hp, 36.5 kW, Deutz D2.9L, Diesel, T4f	✓	✓	✓	
	49 hp, 36 kW, Perkins 404F-E22T, Turbo Diesel, T4f			○	
	60 hp, 44.7 kW, Ford MSG425 gas/LPG Dual Fuel (On Tires only)			○	
	74 hp, 55 kW, Deutz TD2.9L4 turbo diesel, Tier 4f (TraX only)	✓	✓	✓	
	Cold weather package			○	
	Diesel air intake pre-cleaner			○	
	Engine gauge package			○	
	LPG tank 33.5 lb		○	○	
	LPS fire protection rating			○	
	Positive air shutdown system			○	
	Auto engine fault shutdown	✓	✓	✓	
	Platform	6ft/1.83m dual-entry platform with side swing gate			○
		8ft/2.44m tri-entry platform with side swing gate	✓	✓	✓
Dual axis joystick steering		✓	✓	✓	
Thumb rocker steering				○	
Air line to platform				○	
Control box covers			○	○	
Lift Guard Full Mesh panels				○	
Lift Guard Half Mesh panels				○	
Light Package: drive and work lights			○	○	
Platform auxiliary top rail				○	
3kW AC Generator, 110V/60Hz				○	
3kW AC Generator, 220V/50Hz				○	
12kW Welder Ready AC Generator				○	
5ft/1.52m Jib		✓	✓	✓	
AC Power cord to platform		✓	✓	✓	
Alarm package: flashing beacons, descent, travel and tilt alarms		✓	✓	✓	
Drive enable system		✓	✓	✓	
Horn		✓	✓	✓	
Lift Guard Contact Alarm		✓	✓	✓	
Lift Tools Work Tray		✓	✓	✓	
Platform load sense system	✓	✓	✓		
Proportional controls	✓	✓	✓		
Self-leveling platform	✓	✓	✓		
Chassis	Lift Connect Telematics		○	○	
	Telematics-ready	✓	○	✓	
	Lift Connect with Access Manager upgrade		○	○	
	Biodegradable hydraulic oil			○	
	Cold weather hydraulic oil			○	
	Fire resistant hydraulic oil			○	
	Rough terrain, foam-filled tires	✓	✓	✓	
	Rough terrain, foam-filled, non-marking tires		○	○	
	TraX track drive system			○	
	2 wheel steering	✓	✓	✓	
	4 wheel steering			○	
	Deluxe hostile environment kit			○	
	Hostile environment kit			○	
	Tow package			○	
	2 speed wheel motors	✓	✓	✓	
	Active oscillating axle	✓	✓	✓	
	Chassis tilt drive function cut-out	✓	✓	✓	
	Chassis tilt lift function cut-out	✓	✓	✓	
Dual parallelogram lift linkage	✓	✓	✓		
Hour meter	✓	✓	✓		
Hydraulic oil cooler	✓	✓	✓		

Positive air shutdown Deutz engines only

- S Standard
- S+ Standard +
- BtO Build to Order
- ✓ Standard Features
- Options



Zero Tailswing



Rugged Terrainability



Genie FastMast



Genie Genuine Accessories⁽¹⁾

- Lift Tools Productivity Tools
- Lift Connect Telematics
- Tech Pro Link Handheld Device

(1) More accessories available from Genie Genuine Parts.

Product specifications are subject to change without notice or obligation. Photographs and/or drawings herein are for illustrative purposes only. Refer to the appropriate Operator's Manual for instructions on proper equipment use. Failure to follow instructions in the Operator's Manual may result in serious injury or death. The only warranty applicable to our equipment is the standard written warranty applicable to the particular product and sale and we make no other warranty, express or implied. Products and services listed may be trademarks, service marks or trade names of Terex Corporation and/or their subsidiaries in the USA and many other countries. Terex, Genie, Quality By Design, Xtra Capacity, Lift Power, Lift Guard, Lift Tools, Lift Connect and Tech Pro Link are registered trademarks of Terex Corporation or its subsidiaries.



Genie® Z®-80/60

Specifications

Models	Z-80/60	
Measurements	US	Metric
Working height max. ⁽¹⁾	84 ft	25.77 m
Platform height max.	78 ft	23.77 m
Horizontal reach max.	60 ft	18.29 m
Below ground reach	15 ft 10 in	4.83 m
Up and over clearance max.	29 ft	8.83 m
A Platform length (8 ft/6 ft)	3 ft/2 ft 6 in	0.91 m/0.76 m
B Platform width (8 ft/6 ft)	8 ft/6 ft	2.44 m/1.83 m
C Height - stowed	9 ft 10 in	3.00 m
D Length - stowed	37 ft	11.27 m
D Length - storage/transport (jib tucked under)	24 ft 10.5 in	7.3 m
E Length - transport	37 ft	11.27 m
F Width	8 ft 2 in	2.49 m
G Wheelbase	9 ft 4 in	2.85 m
H Ground clearance - center	12 in	0.30 m

Productivity

Lift capacity max. - unrestricted	500 lb	227 kg
Platform rotation	160°	
Jib length	6 ft	1.83 m
Vertical jib rotation	135°	
Turntable rotation	360°	
Drive speed - stowed ⁽²⁾	3.0 mph	4.83 km/h
Drive speed - raised	0.68 mph	1.1 km/h
Gradeability - stowed ⁽²⁾	30%	
Tilt sensor activation (front to back/side to side)	4.5° / 4.5°	
Turning radius - inside/outside	14 ft 6 in/24 ft 6 in	4.42 m/7.47 m
Tires	18-625 NHS	

Power

Power	Diesel	
Auxiliary power unit	12V DC	
Hydraulic tank capacity	45 gal	170 L
Fuel tank capacity	35 gal	132 L

Weight⁽³⁾ and Floor Loading⁽⁴⁾

Weight, 2WS	37,500 lb	17,010 kg
Weight, 4WS	38,000 lb	17,237 kg
Tire contact pressure	130 psi	896 kPa
Occupied floor pressure (tires)	377 psf	18.05 kPa

Sound and Vibration Levels

Sound Pressure level (ground workstation)	85 dBA	
Sound Pressure level (platform workstation)	74 dBA	
Vibrations	8 ft 2 in/s ²	2.5 m/s ²

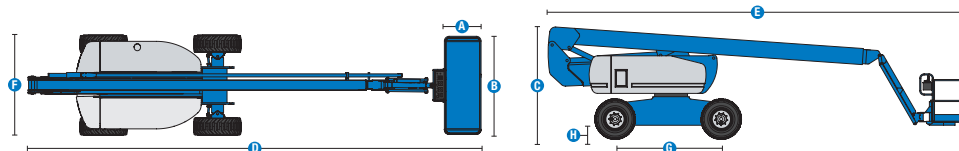

Range of motion Z-80/60

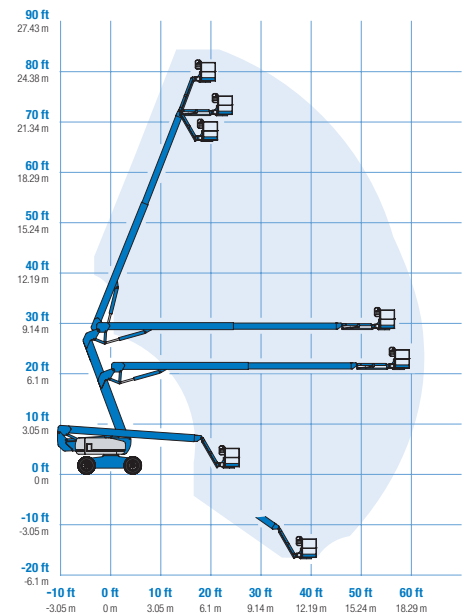

(1) The metric equivalent of working height adds 2m to platform height. The imperial equivalent adds 6ft to platform height.

(2) Gradeability applies to driving on slopes and may vary depending on options and machine configurations. See operator's manual for details regarding slope ratings.

(3) Weight refers to standard configuration and may vary depending on options and/or country standards.

(4) Floor loading information is approximate and may vary depending on options and machine configurations. It should be used only with adequate safety factors.

Genie® Z®-80/60

SKU: Standard Model

- **Z8000001AF0049:** Z-80/60, 4WD
- **Z8000001AF0078:** Z-80/60, 12kW Welder Ready, 4WD, 2WS

* Build to Order

Option availability	S	S+	BtO
Power			
67 hp, 50 kW, Perkins, 404F-E22TA, Turbo Diesel, T4f	✓	✓	✓
70 hp, 52 kW, GM Vortec 3.0L Gas/LPG Dual Fuel	✓	✓	✓
74 hp, 55 kW, Deutz TD2.9L4 turbo diesel, Tier 4f	✓	✓	✓
Cold weather package			○
Diesel air intake pre-cleaner			○
LPG tank 33.5 lb		○	○
Positive air shutdown system			○
Auto engine fault shutdown	✓	✓	✓
Engine gauge display	✓	✓	✓
Platform			
6ft/1.83m dual-entry platform with side swing gate			○
8ft/2.44m tri-entry platform with side swing gate	✓	✓	✓
Dual axis joystick steering	✓	✓	✓
Thumb rocker steering			○
Air line to platform			○
Control box covers		○	○
Lift Guard Full Mesh panels			○
Lift Guard Half Mesh panels			○
Light Package: drive and work lights		○	○
Platform auxiliary top rail			○
3kW AC Generator, 110V/60Hz			○
3kW AC Generator, 220V/50Hz			○
12kW Welder ready			○
6ft/1.83m Jib	✓	✓	✓
AC Power cord to platform	✓	✓	✓
Alarm package: flashing beacons, descent, travel and tilt alarms	✓	✓	✓
Drive enable system	✓	✓	✓
Horn	✓	✓	✓
Lift Guard Contact Alarm	✓	✓	✓
Lift Tools Work Tray	✓	✓	✓
Platform load sense system	✓	✓	✓
Proportional controls	✓	✓	✓
Self-leveling platform	✓	✓	✓
Telescoping riser for up and over	✓	✓	✓
Chassis			
Lift Connect Telematics		○	○
Telematics-ready	✓	✓	✓
Lift Connect with Access Manager upgrade		○	○
Biodegradable hydraulic oil			○
Cold weather hydraulic oil			○
Fire resistant hydraulic oil			○
Rough terrain, foam-filled tires	✓	✓	✓
Rough terrain, foam-filled, non-marking tires		○	○
2 wheel steering	✓	✓	✓
4 wheel steering			○
Deluxe hostile environment kit			○
Hostile environment kit			○
2 speed wheel motors	✓	✓	✓
Active oscillating axle	✓	✓	✓
Chassis tilt drive function cut-out	✓	✓	✓
Chassis tilt lift function cut-out	✓	✓	✓
Hour meter	✓	✓	✓
Hydraulic oil cooler	✓	✓	✓

Positive air shutdown Deutz engines only

- S Standard
- S+ Standard +
- BtO Build to Order
- ✓ Standard Features
- Options



Genie FastMast



3 Steering Modes



Outreach 60ft/18m



Genie Genuine Accessories⁽¹⁾

- Lift Tools Productivity Tools
- Lift Connect Telematics
- Tech Pro Link Handheld Device

(1) More accessories available from Genie Genuine Parts.

Product specifications are subject to change without notice or obligation. Photographs and/or drawings herein are for illustrative purposes only. Refer to the appropriate Operator's Manual for instructions on proper equipment use. Failure to follow instructions in the Operator's Manual may result in serious injury or death. The only warranty applicable to our equipment is the standard written warranty applicable to the particular product and sale and we make no other warranty, express or implied. Products and services listed may be trademarks, service marks or trade names of Terex Corporation and/or their subsidiaries in the USA and many other countries. Terex, Genie, Quality By Design, Xtra Capacity, Lift Power, Lift Guard, Lift Tools, Lift Connect and Tech Pro Link are registered trademarks of Terex Corporation or its subsidiaries.

Genie® ZX™ -135/70

Specifications

Models	ZX-135/70	
Measurements	US	Metric
Working height max. ⁽¹⁾	141 ft	43.15 m
Platform height max.	135 ft	41.15 m
Horizontal reach max. - riser extended	59 ft 2 in	18.03 m
Horizontal reach max. - riser retracted	69 ft 9 in	21.26 m
Up and over clearance max. - riser extended	75 ft 6 in	23.01 m
Up and over clearance max. - riser retracted	32 ft 6 in	9.91 m
Below ground reach	19 ft 3 in	5.87 m
A Platform length	3 ft/2 ft 6 in	0.91 m/0.76 m
B Platform width	8 ft/6 ft	2.44 m/1.83 m
C Height - stowed (tires)	10 ft 1.5 in	3.09 m
D Length - stowed (tires)	42 ft 5 in	12.93 m
E Width (axles retracted)	8 ft 2 in	2.49 m
E Width (axles extended)	12 ft 11 in	3.94 m
F Wheelbase (axles retracted)	13 ft 6 in	4.11 m
F Wheelbase (axles extended)	13 ft 6 in	4.11 m
G Ground clearance - center	1 ft 3 in	0.38 m

Productivity

Lift capacity max. - unrestricted	600 lb	272 kg
Platform rotation	160°	160°
Jib length	12/20 ft	3.66/6.10 m
Vertical jib rotation	110°	110°
Turntable rotation	360°	360°
Drive speed - stowed ⁽²⁾	3.0 mph	4.8 km/h
Drive speed - raised	0.68 mph	1.1 km/h
Gradeability - stowed ⁽²⁾	45%	45%
Tilt sensor activation (front to back/side to side)	4.5° / 4.5°	4.5° / 4.5°
Turning radius - inside/outside (axle retracted)	26 ft 4 in/32 ft 8 in	8.03 m/9.96 m
Turning radius - inside/outside (axle extended)	9 ft 6 in/20 ft 3 in	2.90 m/6.17 m
Tires (foam-filled)	445 D50/710	445 D50/710

Power

Power	Diesel	Diesel
Auxiliary power unit	12V DC	12V DC
Hydraulic tank capacity	65 gal	246.1 L
Fuel tank capacity	40 gal	151 L

Weight⁽³⁾ and Floor Loading⁽⁴⁾

Weight (tires)	46,500 lb	21,092 kg
Tire contact pressure	130 psi	896 kPa
Occupied floor pressure (tires)	209 psf	9.99 kPa

Sound and Vibration Levels

Sound Pressure level (ground workstation)	85 dBA	85 dBA
Sound Pressure level (platform workstation)	74 dBA	74 dBA
Vibrations	8 ft 2 in/s ²	2.5 m/s ²

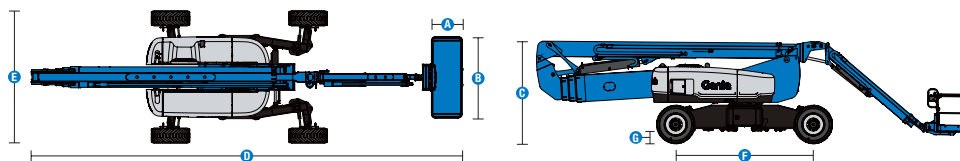

(1) The metric equivalent of working height adds 2m to platform height. The imperial equivalent adds 6ft to platform height.

(2) Gradeability applies to driving on slopes and may vary depending on options and machine configurations. See operator's manual for details regarding slope ratings.

(3) Weight refers to standard configuration and may vary depending on options and/or country standards.

(4) Floor loading information is approximate and may vary depending on options and machine configurations. It should be used only with adequate safety factors.

Range of motion ZX-135/70

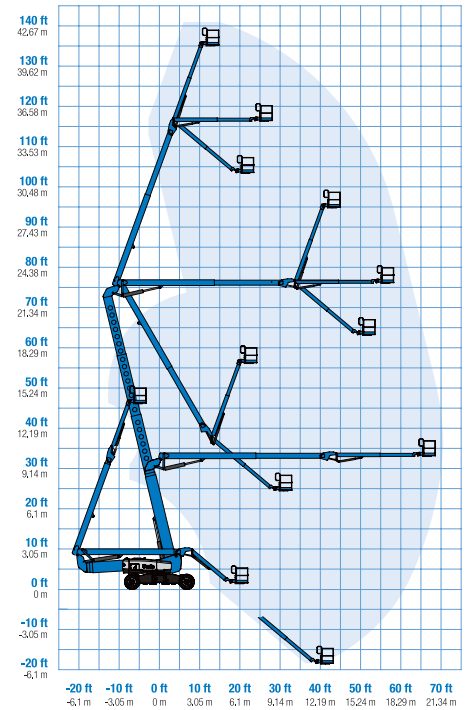

Genie® ZX™ -135/70

SKU: Standard Model

- ZX-135/70, 4WD*
- **ZX135001AF0008:** ZX-135/70, 12kW Welder Ready, 4WD

* Build to Order

Option availability	S	S+	BtO
Power			
74 hp, 55 kW, Deutz TD2.9L4 turbo diesel, Tier 4f	✓	✓	✓
Cold weather package			○
Diesel air intake pre-cleaner			○
Positive air shutdown system			○
Anti-restart engine protection	✓	✓	✓
Auto engine fault shutdown	✓	✓	✓
Auxiliary power unit	✓	✓	✓
Engine gauge display	✓	✓	✓
Platform			
6ft/1.83m dual-entry platform with side swing gate			○
8ft/2.44m tri-entry platform with side swing gate	✓	✓	✓
Dual axis joystick steering	✓	✓	✓
Thumb rocker steering			○
Air line to platform			○
Control box covers		○	○
Lift Guard Full Mesh panels			○
Lift Guard Half Mesh panels			○
Light Package: drive and work lights		○	○
Platform auxiliary top rail			○
3kW AC Generator, 110V/60Hz			○
3kW AC Generator, 220V/50Hz			○
12kW Welder ready			○
AC Power cord to platform	✓	✓	✓
Drive enable system	✓	✓	✓
Horn	✓	✓	✓
Jib Extend 12-20ft/3.66-6.10m	✓	✓	✓
Lift Guard Contact Alarm	✓	✓	✓
Lift Tools Work Tray	✓	✓	✓
Platform load sense system	✓	✓	✓
Proportional controls	✓	✓	✓
Self-leveling platform	✓	✓	✓
Telescoping riser for up and over	✓	✓	✓
Travel alarm package: flashing beacons, descent, travel and tilt alarms	✓	✓	✓
Chassis			
Lift Connect Telematics	✓	✓	✓
Lift Connect with Access Manager upgrade		○	○
Biodegradable hydraulic oil			○
Cold weather hydraulic oil			○
Fire resistant hydraulic oil			○
Rough terrain, foam-filled tires	✓	✓	✓
Deluxe hostile environment kit			○
Hostile environment kit			○
2 speed wheel motors	✓	✓	✓
4 wheel high angle steer	✓	✓	✓
Chassis tilt drive function cut-out	✓	✓	✓
Hour meter	✓	✓	✓
Hydraulic oil cooler	✓	✓	✓
Mini XChassis extendable axles	✓	✓	✓

Positive air shutdown Deutz engines only

- S Standard
- S+ Standard +
- BtO Build to Order
- ✓ Standard Features
- Options



20ft/6.10m Jib-Extend



Mini XChassis



>75ft/23m Up and Over



Genie Genuine Accessories⁽¹⁾

- Lift Tools Productivity Tools
- Lift Connect Telematics
- Tech Pro Link Handheld Device

(1) More accessories available from Genie Genuine Parts.

Product specifications are subject to change without notice or obligation. Photographs and/or drawings herein are for illustrative purposes only. Refer to the appropriate Operator's Manual for instructions on proper equipment use. Failure to follow instructions in the Operator's Manual may result in serious injury or death. The only warranty applicable to our equipment is the standard written warranty applicable to the particular product and sale and we make no other warranty, express or implied. Products and services listed may be trademarks, service marks or trade names of Terex Corporation and/or their subsidiaries in the USA and many other countries. Terex, Genie, Quality By Design, Xtra Capacity, Lift Power, Lift Guard, Lift Tools, Lift Connect and Tech Pro Link are registered trademarks of Terex Corporation or its subsidiaries.

03/22



GENIE® TELESCOPIC S®-BOOM LIFTS

Genie® telescopic S®-boom lifts give operators the height and outreach they need at worksites such as arenas and stadiums, shipyards, refineries, and other industrial areas. Xtra Capacity™ units offer dual lifting capacity for up to 3 operators in the platform, which is especially useful for heavy-lifting applications such as steel erection and welding. Super boom models are the highest-reaching models in the Genie range, ideal for maintenance and inspection jobs on demanding jobsites such as refineries, shipyards and large utilities, to name a few.

SUPERIOR

**HORIZONTAL
OUTREACH**

EXCELLENT

TERRAINABILITY

**UP
TO THREE**

**OPERATORS
ONBOARD**

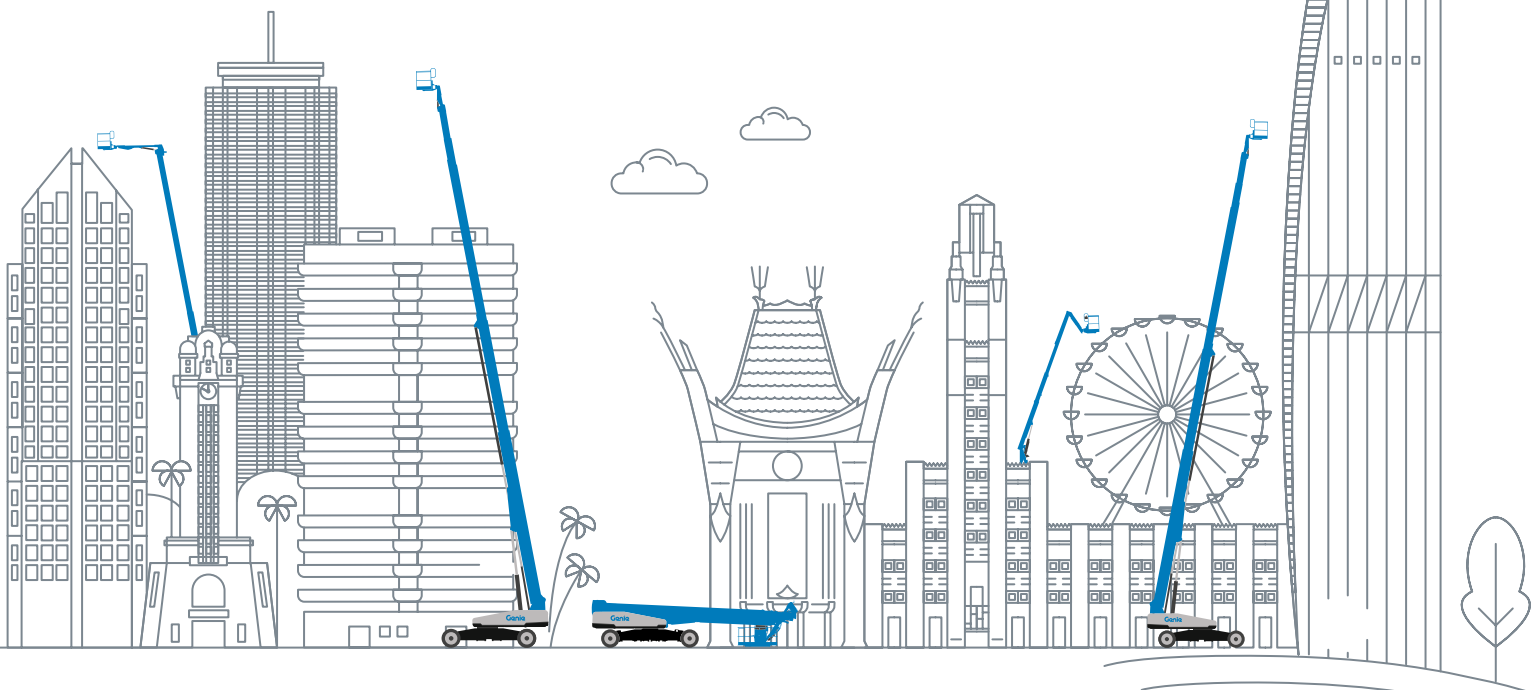

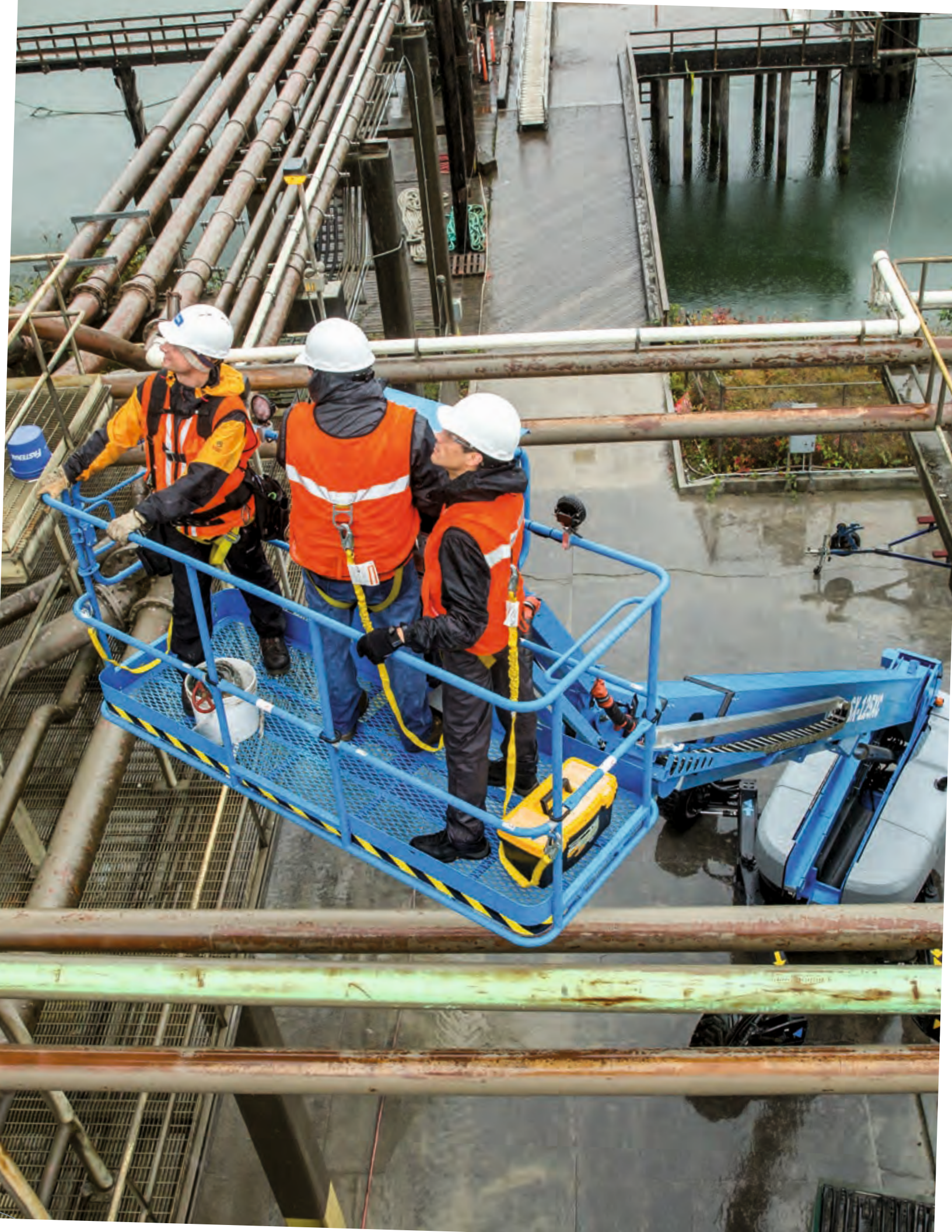

Specifications

Telescopic S[®]-Boom Lifts

MODEL	MAX. PLATFORM HEIGHT	HORIZONTAL REACH	LIFT CAPACITY	WIDTH*	TRANSPORT LENGTH*	WEIGHT*
-------	----------------------	------------------	---------------	--------	-------------------	---------

J Series Telescopic S-Boom Lifts

S [®] -60 J	60 ft 10 in	40 ft 6 in	660 lb	8 ft 2 in	23 ft 6 in	16,650 lb
S-80 J	80 ft 5 in	54 ft 9 in	660 lb	8 ft 2 in	26 ft 2 in	24,500 lb
S-80 J TRAX	80 ft 7 in	54 ft 9 in	660 lb	8 ft 1 in	26 ft 2 in	29,588 lb

Stick Telescopic S-Boom Lifts

S-40 XC	39 ft 6 in	31 ft 1 in	660/1,000 lb	8 ft 2 in	26 ft 4 in	13,945 lb
S-40 TRAX	39 ft 8 in	31 ft 1 in	660/1,000 lb	8 ft 1.6 in	26 ft 4 in	17,120 lb
S-40 HF	39 ft 6 in	28 ft 11 in	600 lb	8 ft 5 in	26 ft 4 in	13,544 lb
S-45 XC	44 ft 6 in	36 ft 2 in	660/1,000 lb	8 ft 2 in	31 ft 1 in	15,800 lb
S-45 TRAX	44 ft 8 in	36 ft 2 in	660/1,000 lb	8 ft 1.6 in	31 ft 1 in	19,010 lb
S-45 HF	44 ft 6 in	34 ft	600 lb	8 ft 5 in	31 ft 1 in	15,720 lb
S-60 DC	61 ft 2 in	40 ft 6 in	660 lb	8 ft 2 in	23 ft 6 in	17,600 lb
S-60 FE	61 ft 2 in	40 ft 6 in	660 lb	8 ft 2 in	23 ft 6 in	17,750 lb
S-65 XC	65 ft	54 ft 2 in	660/1,000 lb	8 ft 2 in	25 ft 7 in	25,160 lb
S-65 TRAX	65 ft 2 in	54 ft 2 in	660/1,000 lb	8 ft 1.6 in	25 ft 7 in	28,877 lb
S-65 HF	65 ft 2 in	51 ft 2 in	600/1,000 lb	8 ft 5 in	25 ft 7 in	24,454 lb
S-85 XC	85 ft	74 ft 6 in	660/1,000 lb	8 ft 2 in	33 ft 8 in	39,500 lb
S-85 XC E & S-85 XC FE	85 ft	74 ft 6 in	660/1,000 lb	8 ft 2 in	34 ft 6 in	38,908 lb/39,592 lb
S-85 HF	85 ft	72 ft 6 in	600/1,000 lb	8 ft 6 in	33 ft 8 in	38,000 lb

Super Telescopic S-Boom Lifts

SX [®] -125 XC™	125 ft	80 ft	660/1,000 lb	8 ft 2 in**	40 ft	45,636 lb
SX-135 XC	135 ft	90 ft	660/1,000 lb	8 ft 2 in**	43 ft 7 in	46,900 lb
SX-150	152 ft	80 ft	750 lb	8 ft 2 in**	42 ft 8 in	49,950 lb
SX-180	180 ft	80 ft	750 lb	8 ft 2 in**	42 ft 8 in	55,000 lb

* With standard configuration. Will vary depending on options and/or country standards.

** Axles retracted

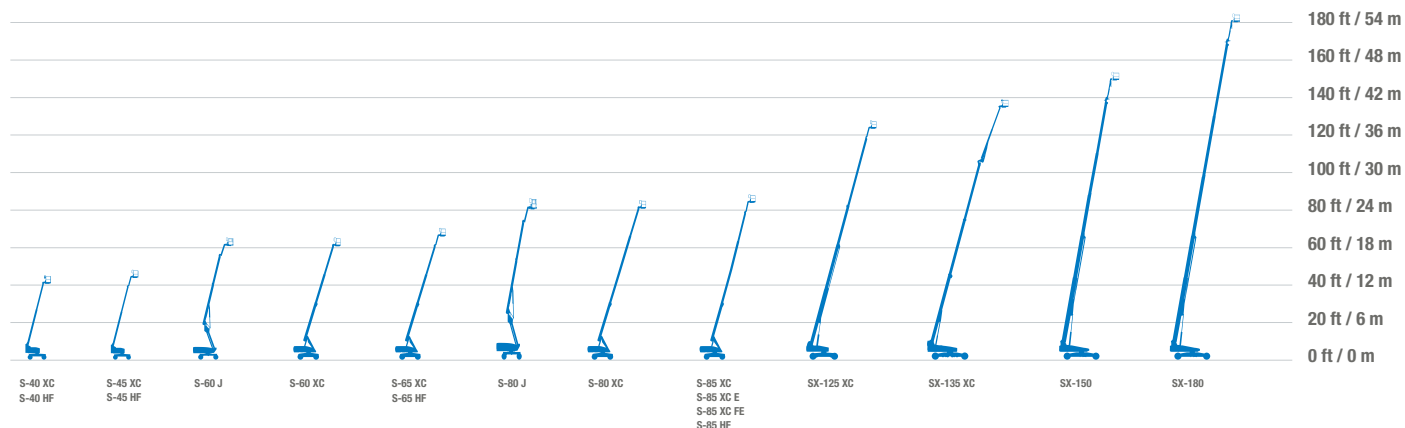

Genie® S®-60 J

Specifications

Models	S-60 J	
Measurements	US	Metric
Working height max. ⁽¹⁾	66 ft 10 in	20.50 m
Platform height max.	60 ft 10 in	18.50 m
Horizontal reach max.	40 ft 6 in	12.30 m
A Platform length (8 ft/6 ft)	3 ft/2 ft 6 in	0.91 m/0.76 m
B Platform width (8 ft/6 ft)	8 ft/6 ft	2.44 m/1.83 m
C Height - stowed	8 ft 10 in	2.69 m
D Length - stowed	31 ft 10 in	9.70 m
D Length - storage/transport (jib tucked under)	23 ft 6 in	7.16 m
E Width	8 ft 2 in	2.49 m
F Wheelbase	8 ft	2.44 m
G Ground clearance - center	1 ft 10 in	0.56 m
H Height under counterweight	3 ft 4 in	

Productivity

Lift capacity max. - unrestricted	660 lb	300 kg
Number of Platform Occupants	2	
Platform rotation	160°	
Jib length	6 ft	1.83 m
Vertical jib rotation (up/down)	130°	
Turntable rotation	353°	
Turntable tailswing	5 ft 2 in	1.57 m
Drive speed - stowed	3 mph	4.82 km/h
Drive speed - raised	0.68 mph	1.1 km/h
Gradeability - stowed ⁽²⁾	45%	
Tilt sensor activation (front to back/side to side)	5° / 5°	
Turning radius - inside/outside	8 ft 1 in/18 ft 5 in	2.46 m/5.61 m
Tires	315/55D20	

Power

Power	Diesel	
Hydraulic tank capacity	21 gal	79 L
Fuel tank capacity	30 gal	114 L

Weight⁽³⁾ and Floor Loading⁽⁴⁾

Weight	16,650 lb	7,550 kg
Tire contact pressure	85 psi	585 kPa
Occupied floor pressure	215 psf	10.28 kPa

Sound and Vibration Levels

Sound Pressure level (ground workstation)	83 dBA
Sound Pressure level (platform workstation)	77 dBA
Vibrations	< 2.5 m/s ²

Range of motion S-60 J

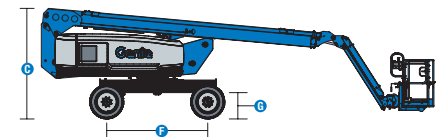
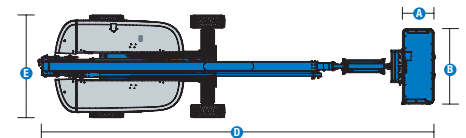
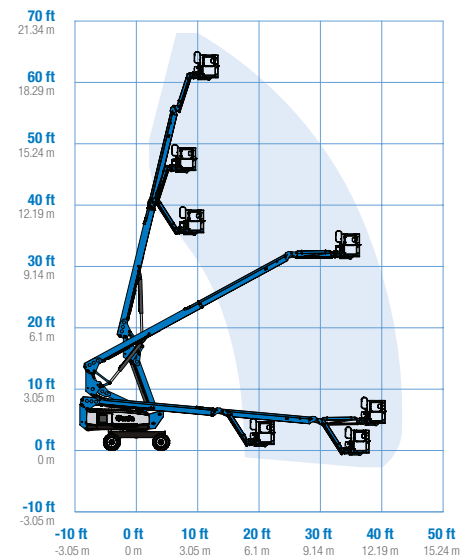

(1) The metric equivalent of working height adds 2 m to platform height. The imperial equivalent adds 6 ft to platform height.

(2) Gradeability applies to driving on slopes and may vary depending on options and machine configurations. See operator's manual for details regarding slope ratings.

(3) Weight refers to standard configuration and may vary depending on options and/or country standards.

(4) Floor loading information is approximate and may vary depending on options and machine configurations. It should be used only with adequate safety factors.

Genie® S® -60 J

SKU: Standard Model

- **S60J0001AF0004:** S-60 J, 4WD
- **S60J0001AF0006:** S-60 J, Lift Power 3kW, Cold weather package, 4WD

* Build to Order

Option availability		S	S+	BtO
Power	24.8 hp, 18.5kW, Kubota D1105, Diesel, T4i/T4f, Stage IIIA/IV, CN IV	✓	✓	✓
	49 hp, 36.5 kW, Kubota D1803, Turbo Diesel, T4f/Stage V			○
	Cold weather package			○
	Diesel air intake pre-cleaner			○
	Positive air shutdown system			○
	Anti-restart engine protection	✓	✓	✓
	Auto engine fault shutdown	✓	✓	✓
	In cylinder glow plug (diesel only)	✓	✓	✓
	Platform	6ft/1.83m dual-entry platform with side swing gate		
8ft/2.44m tri-entry platform with side swing gate		✓	✓	✓
Dual axis joystick steering		✓	✓	✓
Thumb rocker steering				○
Air line to platform				○
Control box covers			○	○
Lift Guard Full Mesh panels				○
Lift Guard Half Mesh panels				○
Light Package: drive and work lights			○	○
Platform auxiliary top rail				○
Lift Power 3kW AC Generator, 110V/60Hz				○
Lift Power 3kW AC Generator, 220V/50Hz				○
Lift Power 12kW Welder Ready AC Generator				○
Drive enable system		✓	✓	✓
Horn		✓	✓	✓
Lift Guard Contact Alarm		✓	✓	✓
Lift Tools Work Tray		✓	✓	✓
Platform load sense system		✓	✓	✓
Proportional controls	✓	✓	✓	
Self-leveling platform	✓	✓	✓	
Chassis	Lift Connect Telematics	✓	✓	✓
	Telematics-ready	✓	✓	✓
	Lift Connect with Access Manager upgrade		○	○
	Biodegradable hydraulic oil			○
	Cold weather hydraulic oil			○
	Fire resistant hydraulic oil			○
	Rough terrain, foam-filled tires	✓	✓	✓
	Rough terrain, foam-filled, non-marking tires		○	○
	Deluxe hostile environment kit			○
	Hostile environment kit			○
	2 speed wheel motors	✓	✓	✓
	Active oscillating axle	✓	✓	✓
	Alarm package: includes flashing beacon and travel alarm	✓	✓	✓
	Chassis tilt lift and drive function cut-out	✓	✓	✓
	Descent, tilt and motion alarm	✓	✓	✓
Hour meter	✓	✓	✓	
Hydraulic oil cooler	✓	✓	✓	
Positive traction drive	✓	✓	✓	
Tech Pro Link connector	✓	✓	✓	

- S Standard
- S+ Standard +
- BtO Build to Order
- ✓ Standard Features
- Options



660lb/300kg Capacity Jib



Low Transport Weight



Simple Design & Maintenance



Genie Genuine Accessories⁽¹⁾

- Lift Tools Productivity Tools
- Lift Connect Telematics
- Tech Pro Link Handheld Device

(1) More accessories available from Genie Genuine Parts.

Product specifications are subject to change without notice or obligation. Photographs and/or drawings herein are for illustrative purposes only. Refer to the appropriate Operator's Manual for instructions on proper equipment use. Failure to follow instructions in the Operator's Manual may result in serious injury or death. The only warranty applicable to our equipment is the standard written warranty applicable to the particular product and sale and we make no other warranty, express or implied. Products and services listed may be trademarks, service marks or trade names of Terex Corporation and/or their subsidiaries in the USA and many other countries. Terex, Genie, Quality By Design, Xtra Capacity, Lift Power, Lift Guard, Lift Tools, Lift Connect and Tech Pro Link are registered trademarks of Terex Corporation or its subsidiaries.

Genie® S®-80 J & S-80 J TraX™

Specifications

Models	S-80 J & S-80 J TraX	
Measurements	US	Metric
Working height max. ⁽¹⁾	86 ft 5 in	26.51 m
Working height max.(TraX) ⁽¹⁾	86 ft 7 in	26.56 m
Platform height max.	80 ft 5 in	24.51 m
Platform height max.(TraX)	80 ft 7 in	24.56 m
Horizontal reach max.	54 ft 9 in	16.69 m
A Platform length (8 ft/6 ft)	3 ft/2 ft 6 in	0.91 m/0.76 m
B Platform width (8 ft/6 ft)	8 ft/6 ft	2.44 m/1.83 m
C Height - stowed (tires)	9 ft	2.74 m
C Height - stowed (TraX)	9 ft 4 in	2.84 m
D Length - stowed (tires)	34 ft 3 in	10.44 m
D Length - stowed (TraX)	34 ft 3 in	10.44 m
D Length - storage/transport (jib tucked under)	26 ft 2 in	7.98 m
E Width (tires)	8 ft 2 in	2.49 m
E Width (TraX)	8 ft 1 in	2.46 m
F Wheelbase	10 ft	3.05 m
G Ground clearance - center (tires)	14 in	0.36 m
G Ground clearance - center (TraX)	18 in	0.46 m
H Height under counterweight	3 ft 7 in	1.09 m

Productivity

Lift capacity max. - unrestricted	660 lb	300 kg
Number of Platform Occupants	2	
Platform rotation	160°	
Jib length	6 ft	1.83 m
Vertical jib rotation (up/down)	130°	
Turntable rotation	355°	
Turntable tailswing	8 ft 4 in	2.54 m
Drive speed - stowed (tires)	3.0 mph	4.8 km/h
Drive speed - stowed (TraX)	1.95 mph	3.14 km/h
Drive speed - raised (tires)	0.72 mph	1.6 km/h
Drive speed - raised (TraX)	0.63 mph	1.01 km/h
Gradeability - stowed ⁽²⁾	45%	
Tilt sensor activation (front to back/side to side)	4.5° / 4.5°	
Turning radius - inside/outside (tires)	15 ft 6 in/25 ft 7.22 in	4.70 m/7.80 m
Turning radius - inside/outside (TraX)	16 ft 3.5 in/26 ft 6 in	4.97 m/8.08 m
Tires	355/55D625	
Track system - 4 points	TraX	

Power

Power	Diesel	
Hydraulic tank capacity	23 gal	87 L
Fuel tank capacity	30 gal	114 L

Weight⁽³⁾ and Floor Loading⁽⁴⁾

Weight (tires)	24,500 lb	11,113 kg
Weight (TraX)	29,588 lb	13,421 kg
Tire contact pressure	91 psi	627 kPa
Track contact pressure	33 psi	227.5 kPa
Occupied floor pressure (tires)	243 psf	11.61 kPa
Occupied floor pressure (TraX)	291 psf	13.93 kPa

Sound and Vibration Levels

Sound Pressure level (ground workstation)	83.4 dBA	
Sound Pressure level (platform workstation)	75.5 dBA	
Vibrations	< 2.5 m/s ²	< 2.5 m/s ²

(1) The metric equivalent of working height adds 2m to platform height. The imperial equivalent adds 6ft to platform height.

(2) Gradeability applies to driving on slopes and may vary depending on options and machine configurations. See operator's manual for details regarding slope ratings.

(3) Weight refers to standard configuration and may vary depending on options and/or country standards.

(4) Floor loading information is approximate and may vary depending on options and machine configurations. It should be used only with adequate safety factors.

Range of motion S-80 J/S-80 J TraX

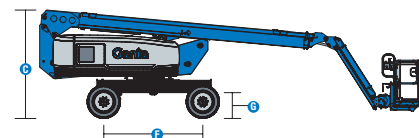
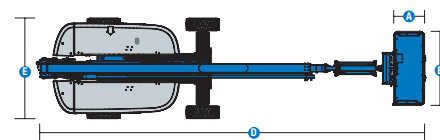
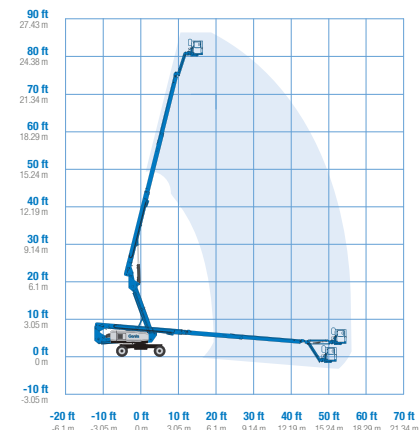

Genie® S® -80 J & S-80 J TraX™

SKU: Standard Model

- **S80J0001AF0036:** S-80 J, 4WD
- **S80J0001AF0038:** S-80 J, Lift Power 12kW Welder Ready, Cold weather package, 4WD
- **S80J0001AF0037:** S-80 J, Lift Power 3kW, Cold weather package, 4WD

* Build to Order

Option availability	S	S+	BtO
Power			
49 hp, 36.5 kW, Kubota D1803, Turbo Diesel, T4f/Stage V	✓	✓	✓
Cold weather package			○
Diesel air intake pre-cleaner			○
Positive air shutdown system			○
Anti-restart engine protection	✓	✓	✓
Auto engine fault shutdown	✓	✓	✓
In cylinder glow plug (diesel only)	✓	✓	✓
Platform			
6ft/1.83m dual-entry platform with side swing gate			○
8ft/2.44m tri-entry platform with side swing gate	✓	✓	✓
Dual axis joystick steering	✓	✓	✓
Thumb rocker steering			○
Air line to platform			○
Control box covers		○	○
Lift Guard Full Mesh panels			○
Lift Guard Half Mesh panels			○
Light Package: drive and work lights		○	○
Platform auxiliary top rail			○
Lift Power 3kW AC Generator, 110V/60Hz			○
Lift Power 3kW AC Generator, 220V/50Hz			○
Lift Power 12kW Welder Ready AC Generator			○
Drive enable system	✓	✓	✓
Horn	✓	✓	✓
Lift Guard Contact Alarm	✓	✓	✓
Lift Tools Work Tray	✓	✓	✓
Platform load sense system	✓	✓	✓
Proportional controls	✓	✓	✓
Self-leveling platform	✓	✓	✓
Chassis			
Lift Connect Telematics		○	○
Telematics-ready	✓	✓	✓
Lift Connect with Access Manager upgrade		○	○
Biodegradable hydraulic oil			○
Cold weather hydraulic oil			○
Fire resistant hydraulic oil			○
Rough terrain, foam-filled tires	✓	✓	✓
Rough terrain, foam-filled, non-marking tires		○	○
TraX track drive system			○
Deluxe hostile environment kit			○
Hostile environment kit			○
2 speed wheel motors	✓	✓	✓
Active oscillating axle	✓	✓	✓
Alarm package: includes flashing beacon and travel alarm	✓	✓	✓
Chassis tilt lift and drive function cut-out	✓	✓	✓
Descent, tilt and motion alarm	✓	✓	✓
Hour meter	✓	✓	✓
Hydraulic oil cooler	✓	✓	✓
Positive traction drive	✓	✓	✓
Tech Pro Link connector	✓	✓	✓

- S Standard
- S+ Standard +
- BtO Build to Order
- ✓ Standard Features
- Options



660lb/300kg Capacity Jib



Low Transport Weight



Simple Design & Maintenance

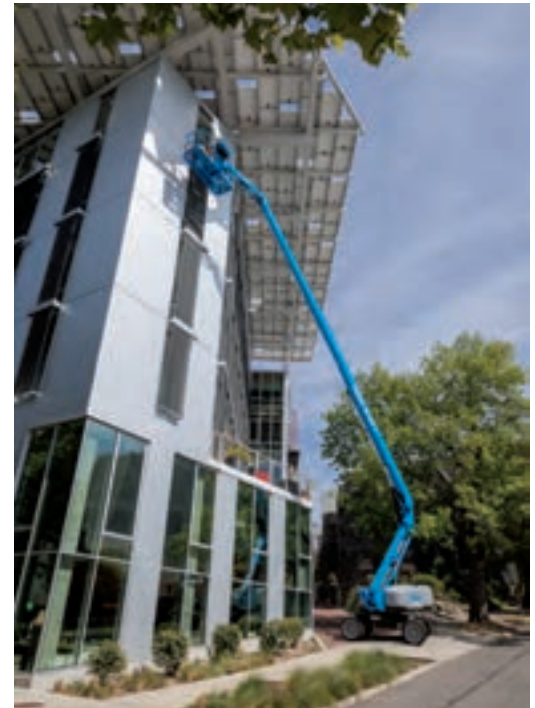

Genie Genuine Accessories⁽¹⁾

- Lift Tools Productivity Tools
- Lift Connect Telematics
- Tech Pro Link Handheld Device

(1) More accessories available from Genie Genuine Parts.

Product specifications are subject to change without notice or obligation. Photographs and/or drawings herein are for illustrative purposes only. Refer to the appropriate Operator's Manual for instructions on proper equipment use. Failure to follow instructions in the Operator's Manual may result in serious injury or death. The only warranty applicable to our equipment is the standard written warranty applicable to the particular product and sale and we make no other warranty, express or implied. Products and services listed may be trademarks, service marks or trade names of Terex Corporation and/or their subsidiaries in the USA and many other countries. Terex, Genie, Quality By Design, Xtra Capacity, Lift Power, Lift Guard, Lift Tools, Lift Connect and Tech Pro Link are registered trademarks of Terex Corporation or its subsidiaries.

Genie® S®-40 XC™ & S-45 XC, S-40 TraX™ & S-45 TraX

Specifications

Models	S-40 XC & S-40 TraX		S-45 XC & S-45 TraX	
Measurements	US	Metric	US	Metric
Working height max. ⁽¹⁾	45 ft 6 in	14,04 m	50 ft 6 in	15,56 m
Working height max.(TraX) ⁽¹⁾	45 ft 8 in	14,09 m	50 ft 8 in	15,61 m
Platform height max.	39 ft 6 in	12,04 m	44 ft 6 in	13,56 m
Platform height max.(TraX)	39 ft 8 in	12,09 m	44 ft 8 in	13,61 m
Horizontal reach max.	31 ft 1 in	9,47 m	36 ft 2 in	11,02 m
Below ground reach	1 ft	0,30 m	4 ft 2 in	1,27 m
A Platform length (8 ft/6 ft)	3 ft/2 ft 6 in	0,91 m/0,76 m	3 ft/2 ft 6 in	0,91 m/0,76 m
B Platform width (8 ft/6 ft)	8 ft/6 ft	2,44 m/1,83 m	8 ft/6 ft	2,44 m/1,83 m
C Height - stowed (tires)	8 ft 3 in	2,51 m	8 ft 3 in	2,51 m
D Height - stowed (TraX)	8 ft 6 in	2,59 m	8 ft 6 in	2,59 m
E Length - stowed (tires)	26 ft 4 in	8,03 m	31 ft 1 in	9,47 m
F Length - stowed (TraX)	26 ft 4 in	8,03 m	31 ft 1 in	9,47 m
G Width (tires)	8 ft 2 in	2,49 m	8 ft 2 in	2,49 m
H Width (TraX)	8 ft 1,6 in	2,48 m	8 ft 1,6 in	2,48 m
I Wheelbase	8 ft 1 in	2,46 m	8 ft 1 in	2,46 m
J Ground clearance - center (tires)	1 ft .5 in	0,32 m	1 ft .5 in	0,32 m
K Ground clearance - center (TraX)	1 ft 7 in	0,48 m	1 ft 7 in	0,48 m
L Height under counterweight	3 ft 4 in	1,02 m	3 ft 4 in	1,02 m

Productivity

Lift capacity max. - unrestricted	660 lb	300 kg	660 lb	300 kg
Lift capacity max. - restricted	1 000 lb	454 kg	1 000 lb	454 kg
Number of Platform Occupants (restricted/unrestricted)	3/2		3/2	
Platform rotation	160°		160°	
Jib length	—		5 ft	1,52 m
Vertical jib rotation (up/down)	—		133°	
Turntable rotation	360°		360°	
Turntable tailswing	38 in	0,97 m	38 in	0,97 m
Drive speed - stowed (tires)	4,0 mph	6,40 km/h	4,0 mph	6,40 km/h
Drive speed - stowed (TraX)	2,04 mph	3,28 km/h	2,04 mph	3,28 km/h
Drive speed - raised (tires)	0,68 mph	1,1 km/h	0,68 mph	1,1 km/h
Drive speed - raised (TraX)	0,68 mph	1,1 km/h	0,68 mph <td 1,1 km/h	
Gradeability - stowed ⁽²⁾	45%		45%	
Tilt sensor activation (front to back/side to side)	7°/5°		7°/5°	
Turning radius - inside/outside (tires)	6 ft 10 in/ 17 ft 2 in	2,08 m/ 5,23 m	6 ft 10 in/ 17 ft 2 in	2,08 m/ 5,23 m
Turning radius - inside/outside (TraX)	6 ft 10 in/ 17 ft 2 in	2,08 m/ 5,23 m	6 ft 10 in/ 17 ft 2 in	2,08 m/ 5,23 m
Tires	315/55D20		315/55D20	
Track system - 4 points	TraX		TraX	

Power

Power	Diesel		Diesel	
Hydraulic tank capacity	38 gal	144 L	38 gal	144 L
Fuel tank capacity	35 gal	132 L	35 gal	132 L

Weight⁽³⁾ and Floor Loading⁽⁴⁾

Weight (tires)	13 945 lb	6 325 kg	15 800 lb	7 167 kg
Weight (TraX)	17 120 lb	7 765 kg	19 010 lb	8 623 kg
Tire contact pressure	92 psi	634 kPa	92 psi	634 kPa
Track contact pressure	22 psi	151,7 kPa	25 psi	172,4 kPa
Occupied floor pressure (tires)	162 psf	7,76 kPa	187 psf	8,95 kPa
Occupied floor pressure (TraX)	201 psf	9,6 kPa	223 psf	10,7 kPa

Sound and Vibration Levels

Sound Pressure level (ground workstation)	90 dBA	90 dBA
Sound Pressure level (platform workstation)	77 dBA	77 dBA
Vibrations	< 2,5 m/s ²	< 2,5 m/s ²

(1) The metric equivalent of working height adds 2 m to platform height. The imperial equivalent adds 6 ft to platform height.
 (2) Gradeability applies to driving on slopes and may vary depending on options and machine configurations. See operator's manual for details regarding slope ratings.
 (3) Weight refers to standard configuration and may vary depending on options and/or country standards.
 (4) Floor loading information is approximate and may vary depending on options and machine configurations. It should be used only with adequate safety factors.

Range of motion S-40 XC/S-40 TraX

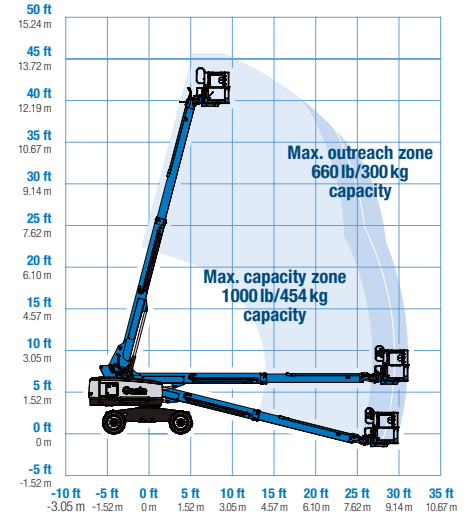

Range of motion S-45 XC/S-45 TraX

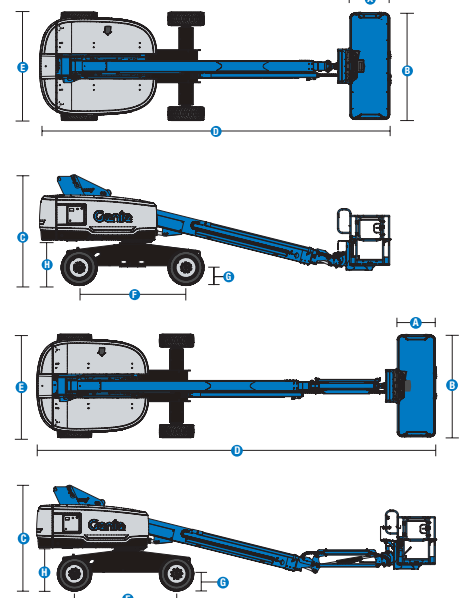
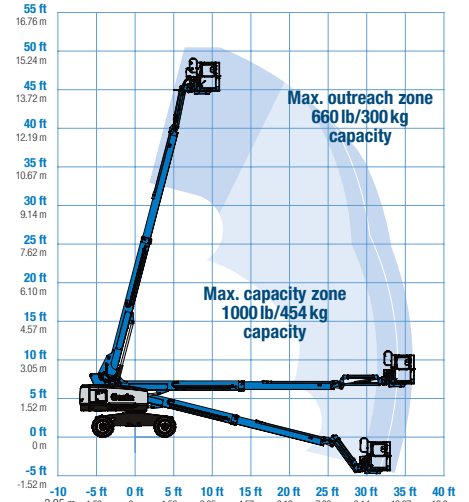

Genie® S® -40 XC™ & S-45 XC, S-40 TraX™ & S-45 TraX

SKU: Standard Model

- **S40XC001AF0017:** S-40 XC, 4WD
- **S40XC001AF0022:** S-40 XC, Lift Power 3kW, 4WD
- **S40XC001AF0023:** S-40 XC, Lift Power 12kW Welder Ready, 4WD

SKU: Standard Model

- **S45XC001AF0051:** S-45 XC, 4WD
- **S45XC001AF0052:** S-45 XC, Lift Power 3kW, 4WD
- **S45XC001AF0099:** S-45 XC, Lift Power 12kW Welder Ready, 4WD

* Build to Order

Option availability	S	S+	BtO	
Power	49 hp, 37 kW, Deutz D2.9L, Diesel, T4f	✓	✓	✓
	49 hp, 37 kW, Perkins 404F-E22T, Turbo Diesel, T4f			○
	60 hp, 45 kW, Ford 2.5L, Gas/LPG			○
	Cold weather package			○
	Positive air shutdown system			○
	Anti-restart engine protection	✓	✓	✓
	Auto engine fault shutdown	✓	✓	✓
	In cylinder glow plug (diesel only)	✓	✓	✓
	Platform	6ft/1,83m dual-entry platform with side swing gate		
8ft/2,44m tri-entry platform with side swing gate		✓	✓	✓
Dual axis joystick steering		✓	✓	✓
Thumb rocker steering				○
Air line to platform				○
Control box covers			○	○
Lift Guard Full Mesh panels				○
Lift Guard Half Mesh panels				○
Light Package: drive and work lights			○	○
Platform auxiliary top rail				○
Lift Power 3kW AC Generator, 110V/60Hz				○
Lift Power 3kW AC Generator, 220V/50Hz				○
Lift Power 12kW Welder Ready				○
660lb/300kg & 1000lb/454kg dual load capacity with automatic envelope control		✓	✓	✓
Drive enable system		✓	✓	✓
Horn		✓	✓	✓
Lift Guard Contact Alarm		✓	✓	✓
Lift Tools Work Tray		✓	✓	✓
Platform load sense system		✓	✓	✓
Proportional controls		✓	✓	✓
Self-leveling platform	✓	✓	✓	
Chassis	Lift Connect Telematics	✓	✓	✓
	Telematics-ready	✓	✓	✓
	Lift Connect with Access Manager upgrade		○	○
	Biodegradable hydraulic oil			○
	Cold weather hydraulic oil			○
	Fire resistant hydraulic oil			○
	High floatation, air-filled tires		○	○
	Rough terrain, foam-filled tires	✓	✓	✓
	Rough terrain, foam-filled, non-marking tires		○	○
	TraX track drive system			○
	Deluxe hostile environment kit			○
	Hostile environment kit			○
	LPG tank 33.5 lb			○
	Tow package			○
	2 speed wheel motors	✓	✓	✓
	Active oscillating axle	✓	✓	✓
	Alarm package: includes flashing beacon and travel alarm	✓	✓	✓
Chassis tilt lift and drive function cut-out	✓	✓	✓	
Descent, tilt and motion alarm	✓	✓	✓	
Dual battery system	✓	✓	✓	
Hour meter	✓	✓	✓	
Hydraulic oil cooler	✓	✓	✓	
Tech Pro Link connector	✓	✓	✓	

Positive air shutdown system for Deutz engines only

- S Standard
- S+ Standard +
- BtO Build to Order
- ✓ Standard Features
- Options



Rugged Terrainability



Xtra Capacity



Zero-Load Calibration



Genie Genuine Accessories⁽¹⁾

- Lift Tools Productivity Tools
- Lift Connect Telematics
- Tech Pro Link Handheld Device

(1) More accessories available from Genie Genuine Parts.

Product specifications are subject to change without notice or obligation. Photographs and/or drawings herein are for illustrative purposes only. Refer to the appropriate Operator's Manual for instructions on proper equipment use. Failure to follow instructions in the Operator's Manual may result in serious injury or death. The only warranty applicable to our equipment is the standard written warranty applicable to the particular product and sale and we make no other warranty, express or implied. Products and services listed may be trademarks, service marks or trade names of Terex Corporation and/or their subsidiaries in the USA and many other countries. Terex, Genie, Quality By Design, Xtra Capacity, Lift Power, Lift Guard, Lift Tools, Lift Connect and Tech Pro Link are registered trademarks of Terex Corporation or its subsidiaries.



Genie® S®-40 HF & S-45 HF

Specifications

Models	S-40 HF		S-45 HF	
Measurements	US	Metric	US	Metric
Working height max. ⁽¹⁾	45 ft 6 in	13.87 m	50 ft 6 in	15.56 m
Platform height max.	39 ft 6 in	12.04 m	44 ft 6 in	13.56 m
Horizontal reach max.	28 ft 11 in	8.81 m	34 ft	10.36 m
Below ground reach	1 ft	0.30 m	4 ft 2 in	1.27 m
A Platform length (8 ft/6 ft)	3 ft/2 ft 6 in	0.91 m/0.76 m	3 ft/2 ft 6 in	0.91 m/0.76 m
B Platform width (8 ft/6 ft)	8 ft/6 ft	2.44 m/1.83 m	8 ft/6 ft	2.44 m/1.83 m
C Height - stowed (tires)	8 ft 3 in	2.51 m	8 ft 3 in	2.51 m
D Length - stowed (tires)	26 ft 4 in	8.03 m	31 ft 1 in	9.47 m
E Width (tires)	8 ft 5 in	2.56 m	8 ft 5 in	2.56 m
F Wheelbase	8 ft 1 in	2.46 m	8 ft 1 in	2.46 m
G Ground clearance - center (tires)	12.5 in	0.32 m	12.5 in	0.32 m
H Height under counterweight	3 ft 4 in	1.02 m	3 ft 4 in	1.02 m

Productivity

Lift capacity max. - unrestricted	600 lb	272 kg	600 lb	272 kg
Number of Platform Occupants	2	2	2	2
Platform rotation	160°	160°	160°	160°
Jib length	—	—	5 ft	1.52 m
Vertical jib rotation (up/down)	—	—	133°	133°
Turntable rotation	360°	360°	360°	360°
Turntable tailswing	36 in	0.91 m	36 in	0.91 m
Drive speed - stowed (tires)	4.0 mph	6.4 km/h	4.0 mph	6.4 km/h
Drive speed - raised (tires)	0.68 mph	1.1 km/h	0.68 mph	1.1 km/h
Gradeability - stowed ⁽²⁾	45%	45%	45%	45%
Tilt sensor activation (front to back/side to side)	5°/5°	5°/5°	5°/5°	5°/5°
Turning radius - inside/outside (tires)	6 ft 9 in/17 ft 3 in	2.06 m/5.26 m	6 ft 9 in/17 ft 3 in	2.06 m/5.26 m
Tires	33/16LL500	33/16LL500	33/16LL500	33/16LL500

Power

Power	Diesel	Diesel	Diesel	Diesel
Hydraulic tank capacity	38 gal	144 L	38 gal	144 L
Fuel tank capacity	35 gal	132 L	35 gal	132 L

Weight⁽³⁾ and Floor Loading⁽⁴⁾

Weight (tires)	13,544 lb	6,143 kg	15,720 lb	7,130 kg
Tire contact pressure	38 psi	262 kPa	38 psi	262 kPa
Occupied floor pressure (tires)	155 psf	7.44 kPa	180 psf	8.63 kPa

Sound and Vibration Levels

Sound Pressure level (ground workstation)	89 dBA	89 dBA	89 dBA	89 dBA
Sound Pressure level (platform workstation)	77 dBA	77 dBA	77 dBA	77 dBA
Vibrations	< 2.5 m/s ²	< 2.5 m/s ²	< 2.5 m/s ²	< 2.5 m/s ²

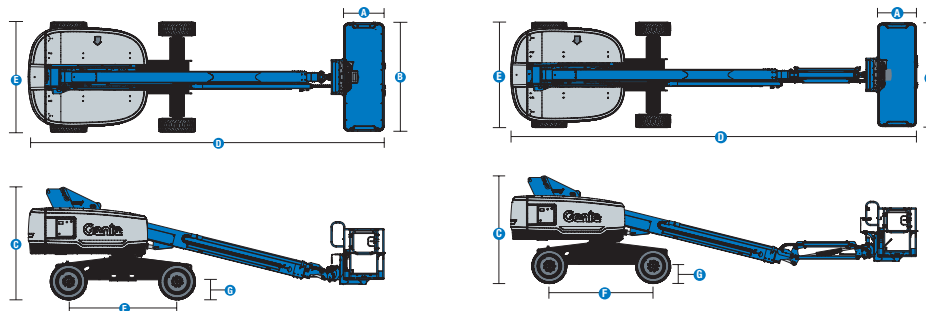

(1) The metric equivalent of working height adds 2m to platform height. The imperial equivalent adds 6ft to platform height.

(2) Gradeability applies to driving on slopes and may vary depending on options and machine configurations. See operator's manual for details regarding slope ratings.

(3) Weight refers to standard configuration and may vary depending on options and/or country standards.

(4) Floor loading information is approximate and may vary depending on options and machine configurations. It should be used only with adequate safety factors.

Range of motion S-40 HF

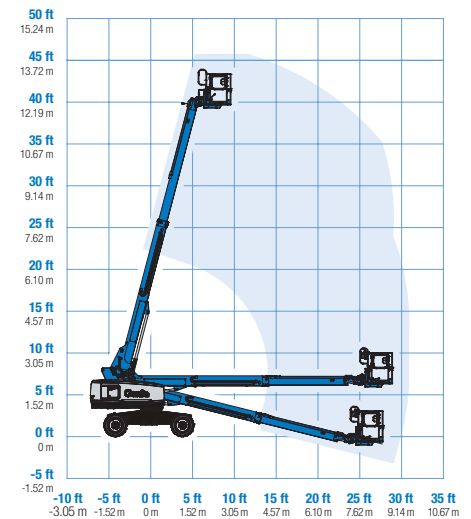

Range of motion S-45 HF

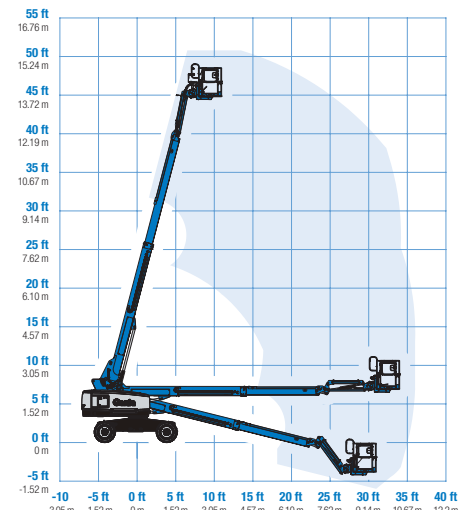

Genie® S® -40 HF & S-45 HF

SKU: Standard Model

- S-40 HF, 4WD*

* Build to Order

SKU: Standard Model

- S-45 HF, 4WD*

Option availability	S	S+	BtO
Power	49 hp, 37 kW, Deutz D2.9L, Diesel, T4f		<input checked="" type="checkbox"/>
	49 hp, 37 kW, Perkins 404F-E22T, Turbo Diesel, T4f		<input type="checkbox"/>
	60 hp, 45 kW, Ford 2.5L, Gas/LPG		<input type="checkbox"/>
	Cold weather package		<input type="checkbox"/>
	Positive air shutdown system		<input type="checkbox"/>
	Anti-restart engine protection		<input checked="" type="checkbox"/>
	Auto engine fault shutdown		<input checked="" type="checkbox"/>
	Diesel air intake pre-cleaner		<input checked="" type="checkbox"/>
	In cylinder glow plug (diesel only)		<input checked="" type="checkbox"/>
	Platform	6ft/1.83m dual-entry platform with side swing gate	
8ft/2.44m tri-entry platform with side swing gate			<input checked="" type="checkbox"/>
6ft/1.83m Aircraft protection platform with sliding mid-rail			<input type="checkbox"/>
6ft/1.83m Aircraft protection platform with side swing gate			<input type="checkbox"/>
Dual axis joystick steering			<input checked="" type="checkbox"/>
Thumb rocker steering			<input type="checkbox"/>
Air line to platform			<input type="checkbox"/>
Control box covers			<input type="checkbox"/>
Lift Guard Full Mesh panels			<input type="checkbox"/>
Lift Guard Half Mesh panels			<input type="checkbox"/>
Light Package: drive and work lights			<input type="checkbox"/>
Platform auxiliary top rail			<input type="checkbox"/>
Lift Power 3kW AC Generator, 110V/60Hz			<input type="checkbox"/>
Lift Power 3kW AC Generator, 220V/50Hz			<input type="checkbox"/>
Lift Power 12kW Welder Ready			<input type="checkbox"/>
Drive enable system			<input checked="" type="checkbox"/>
Horn			<input checked="" type="checkbox"/>
Lift Guard Contact Alarm			<input checked="" type="checkbox"/>
Lift Tools Work Tray			<input checked="" type="checkbox"/>
Platform load sense system			<input checked="" type="checkbox"/>
Proportional controls		<input checked="" type="checkbox"/>	
Self-leveling platform		<input checked="" type="checkbox"/>	
Chassis	Lift Connect Telematics		<input checked="" type="checkbox"/>
	Lift Connect with Access Manager upgrade		<input type="checkbox"/>
	Biodegradable hydraulic oil		<input type="checkbox"/>
	Cold weather hydraulic oil		<input type="checkbox"/>
	Fire resistant hydraulic oil		<input type="checkbox"/>
	High floatation, air-filled tires		<input type="checkbox"/>
	Deluxe hostile environment kit		<input type="checkbox"/>
	Hostile environment kit		<input type="checkbox"/>
	LPG tank 33.5lb		<input type="checkbox"/>
	Tow package		<input type="checkbox"/>
	Active oscillating axle		<input checked="" type="checkbox"/>
	Alarm package: includes flashing beacon and travel alarm		<input checked="" type="checkbox"/>
	Descent, tilt and motion alarm		<input checked="" type="checkbox"/>
	Dual battery system		<input checked="" type="checkbox"/>
	Hour meter		<input checked="" type="checkbox"/>
Hydraulic oil cooler		<input checked="" type="checkbox"/>	
Tech Pro Link connector		<input checked="" type="checkbox"/>	
Wheel motors 2 speed		<input checked="" type="checkbox"/>	

Positive air shutdown system for Deutz engines only

- S** Standard
- S+** Standard +
- BtO** Build to Order
- Standard Features
- Options



Sensitive Terrains



Rugged Terrainability



660lb/300kg Capacity Jib



Genie Genuine Accessories⁽¹⁾

- Lift Tools Productivity Tools
- Lift Connect Telematics
- Tech Pro Link Handheld Device

(1) More accessories available from Genie Genuine Parts.

Product specifications are subject to change without notice or obligation. Photographs and/or drawings herein are for illustrative purposes only. Refer to the appropriate Operator's Manual for instructions on proper equipment use. Failure to follow instructions in the Operator's Manual may result in serious injury or death. The only warranty applicable to our equipment is the standard written warranty applicable to the particular product and sale and we make no other warranty, express or implied. Products and services listed may be trademarks, service marks or trade names of Terex Corporation and/or their subsidiaries in the USA and many other countries. Terex, Genie, Quality By Design, Xtra Capacity, Lift Power, Lift Guard, Lift Tools, Lift Connect and Tech Pro Link are registered trademarks of Terex Corporation or its subsidiaries.

Genie® S®-60 DC & S-60 FE

Specifications

Models	S-60 DC & S-60 FE	
Measurements	US	Metric
Working height max. ⁽¹⁾	67 ft 2 in	20.60 m
Platform height max.	61 ft 2 in	18.60 m
Horizontal reach max.	40 ft 6 in	12.30 m
A Platform length (8 ft/6 ft)	3 ft/2 ft 6 in	0.91 m/0.76 m
B Platform width (8 ft/6 ft)	8 ft/6 ft	2.44 m/1.83 m
C Height - stowed	8 ft 12 in	2.73 m
C Height - storage/transport (jib tucked under)	9 ft 7 in	2.92 m
D Length - stowed	31 ft 8 in	9.65 m
D Length - storage/transport (jib tucked under)	23 ft 6 in	7.16 m
E Width	8 ft 2 in	2.49 m
F Wheelbase	8 ft 2 in	2.49 m
G Ground clearance - center	18.3 in	0.46 m

Productivity

Lift capacity max. - unrestricted	660 lb	300 kg
Number of Platform Occupants	2	
Platform rotation	160°	
Jib length	6 ft	1.83 m
Vertical jib rotation (up/down)	130°	
Turntable rotation	353°	
Turntable tailswing (riser up/riser down)	4 ft 1 in/5 ft 2 in	1.24 m/1.57 m
Drive speed - stowed	4.0 mph	6.44 km/h
Drive speed - raised	0.68 mph	1.1 km/h
Gradeability - stowed ⁽²⁾	45%	
Turning radius - inside/outside	10 ft/17 ft 3 in	3.06 m/5.25 m
Tires	355/55D625	

Power

Drive System	48V 3-Phase AC	
Battery Pack, DC	48V DC (8×6V), 390Ah, FLA	
Battery Pack, FE	48V DC (8×6V), 370Ah, AGM	
AC generator, FE	Diesel	
Auxiliary power unit, FE	12V DC	
Hydraulic tank capacity	18 gal	68 L
Fuel tank capacity	17 gal	64 L

Weight⁽³⁾ and Floor Loading⁽⁴⁾

Weight, DC	17,600 lb	7,983 kg
Weight, FE	17,750 lb	8,051 kg
Tire contact pressure	73 psi	500 kPa
Occupied floor pressure	203 psf	9.74 kPa

Sound and Vibration Levels

Sound Pressure level (ground workstation)	< 70 dBA (DC)/87 dBA (FE)	
Sound Pressure level (platform workstation)	< 70 dBA (DC)/76 dBA (FE)	
Vibrations	1.11 ft/s ²	0.34 m/s ²

Range of motion S-60 DC/S-60 FE

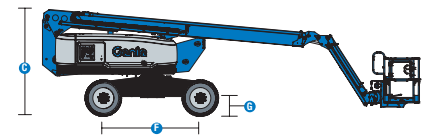
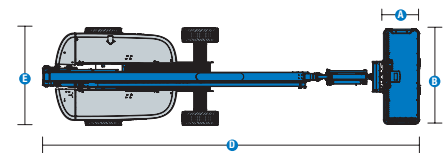
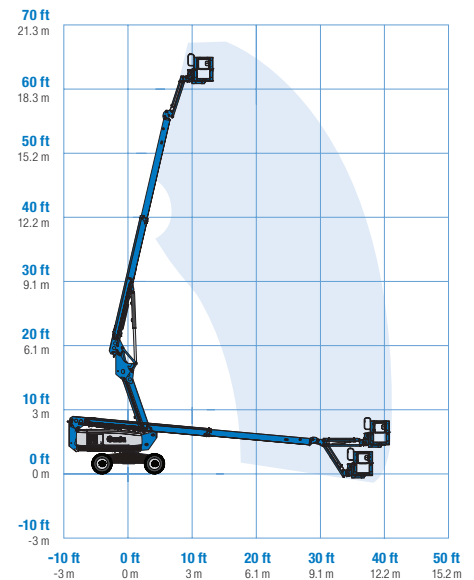

(1) The metric equivalent of working height adds 2m to platform height. The imperial equivalent adds 6ft to platform height.

(2) Gradeability applies to driving on slopes and may vary depending on options and machine configurations. See operator's manual for details regarding slope ratings.

(3) Weight refers to standard configuration and may vary depending on options and/or country standards.

(4) Floor loading information is approximate and may vary depending on options and machine configurations. It should be used only with adequate safety factors.

Genie® S® -60 DC & S-60 FE

SKU: Standard Model

- S-60 DC, DC Power, 4WD*

* Build to Order

SKU: Standard Model

- **S60FE001AE0020:** S-60 FE, Hybrid, 4WD
- **S60FE001AE0021:** S-60 FE, Hybrid, 4WD, cold weather package
- **S60FE001AE0022:** S-60 FE, Hybrid, 4WD, power inverter, 2kW, 120V/60Hz

Option availability	S	S+	BtO
Power			
24.8 hp, 18.5kW, Kubota D1105, Diesel, T4i/T4f, Stage IIIA/IV, CN IV (FE model only)	✓	✓	✓
FLA flooded lead acid batteries (DC model only)		✓	✓
AGM Maintenance-free batteries (Optional on DC)	✓	✓	✓
Power inverter, 2kW, 120V/60Hz		○	○
12V DC auxiliary power unit	✓	✓	✓
3-phase AC drive system	✓	✓	✓
48V solid state battery charger	✓	✓	✓
Low voltage interrupt (LVI) with battery charge indicator (BCI)	✓	✓	✓
Platform			
6ft/1.83m dual-entry platform with side swing gate			○
8ft/2.44m tri-entry platform with side swing gate	✓	✓	✓
Power to platform with RCBO	✓	✓	✓
Dual axis joystick steering	✓	✓	✓
Thumb rocker steering			○
Air line to platform			○
Control box covers		○	○
Control box covers		○	○
Lift Guard Full Mesh panels			○
Lift Guard Half Mesh panels			○
Light Package: drive and work lights		○	○
Platform auxiliary top rail			○
AC Power cord to platform	✓	✓	✓
Drive enable system	✓	✓	✓
Horn	✓	✓	✓
Lift Guard Contact Alarm	✓	✓	✓
Lift Tools Work Tray	✓	✓	✓
Platform load sense system	✓	✓	✓
Proportional controls	✓	✓	✓
Self-leveling platform	✓	✓	✓
Chassis			
Lift Connect Telematics		○	○
Telematics-ready	✓	✓	✓
Lift Connect with Access Manager upgrade		○	○
Biodegradable hydraulic oil			○
Cold weather hydraulic oil			○
Fire resistant hydraulic oil			○
Rough terrain, foam-filled tires		○	○
Rough terrain, foam-filled, non-marking tires	✓	✓	✓
Hostile environment kit			○
Tow package			○
Active oscillating axle	✓	✓	✓
Alarm package: flashing beacons, descent, travel and tilt alarms	✓	✓	✓
Chassis tilt lift and drive function cut-out	✓	✓	✓
Descent, tilt and motion alarm	✓	✓	✓
Electric brake release	✓	✓	✓
Hour meter	✓	✓	✓
On-board diagnostic system	✓	✓	✓

- S Standard
- S+ Standard +
- BtO Build to Order
- ✓ Standard Features
- Options



4 AC Drive motors



Rugged Terrainability



Low Noise, Low Emissions



Genie Genuine Accessories⁽¹⁾

- Lift Tools Productivity Tools
- Lift Connect Telematics
- Tech Pro Link Handheld Device

(1) More accessories available from Genie Genuine Parts.

Product specifications are subject to change without notice or obligation. Photographs and/or drawings herein are for illustrative purposes only. Refer to the appropriate Operator's Manual for instructions on proper equipment use. Failure to follow instructions in the Operator's Manual may result in serious injury or death. The only warranty applicable to our equipment is the standard written warranty applicable to the particular product and sale and we make no other warranty, express or implied. Products and services listed may be trademarks, service marks or trade names of Terex Corporation and/or their subsidiaries in the USA and many other countries. Terex, Genie, Quality By Design, Xtra Capacity, Lift Power, Lift Guard, Lift Tools, Lift Connect and Tech Pro Link are registered trademarks of Terex Corporation or its subsidiaries.

Genie® S®-65 XC™ & S-65 TraX™

Specifications

Models	S-65 XC & S-65 TraX	
Measurements	US	Metric
Working height max. ⁽¹⁾	71 ft	21.81 m
Working height max.(TraX) ⁽¹⁾	71 ft 2 in	21.86 m
Platform height max.	65 ft	19.81 m
Platform height max.(TraX)	65 ft 2 in	19.86 m
Horizontal reach max.	54 ft 2 in	16.51 m
Below ground reach	8 ft 8 in	2.65 m
A Platform length (8 ft/6 ft)	3 ft/2 ft 6 in	0.91 m/0.76 m
B Platform width (8 ft/6 ft)	8 ft/6 ft	2.44 m/1.83 m
C Height - stowed (tires)	9 ft 3 in	2.81 m
C Height - stowed (TraX)	9 ft 5 in	2.87 m
D Length - stowed (tires)	32 ft	9.76 m
D Length - stowed (TraX)	32 ft	9.76 m
D Length - storage/transport (jib tucked under)	25 ft 7 in	7.80 m
E Width (tires)	8 ft 2 in	2.49 m
E Width (TraX)	8 ft 1.6 in	2.48 m
F Wheelbase	8 ft 2 in	2.49 m
G Ground clearance - center (tires)	16.3 in	0.41 m
G Ground clearance - center (TraX)	18.6 in	0.47 m
H Height under counterweight	3 ft 10 in	1.17 m

Productivity

Lift capacity max. - unrestricted	660 lb	300 kg
Lift capacity max. - restricted	1,000 lb	454 kg
Number of Platform Occupants (restricted/unrestricted)		3/2
Platform rotation		160°
Jib length	5 ft	1.52 m
Vertical jib rotation (up/down)		133°
Turntable rotation		360°
Turntable tailswing	4 ft 7.5 in	1.41 m
Drive speed - stowed (tires)	3.0 mph	4.8 km/h
Drive speed - stowed (TraX)	2.3 mph	3.7 km/h
Drive speed - raised (tires)	1 ft/s	0.3 m/s
Drive speed - raised (TraX)	0.7 ft/s	0.2 m/s
Gradeability - stowed ⁽²⁾		45%
Tilt sensor activation (front to back/side to side)		7° / 5°
Turning radius - inside/outside (tires)	10 ft 6 in/17 ft 10 in	3.20 m/5.40 m
Turning radius - inside/outside (TraX)	8 ft .5 in/18 ft 5 in	2.45 m/5.60 m
Tires		355/55D625
Track system - 4 points		TraX

Power

Power		Diesel
Hydraulic tank capacity	40 gal	151 L
Fuel tank capacity	35 gal	132 L

Weight⁽³⁾ and Floor Loading⁽⁴⁾

Weight (tires)	25,160 lb	11,412 kg
Weight (TraX)	28,877 lb	13,098 kg
Tire contact pressure	90 psi	620 kPa
Track contact pressure	28 psi	193 kPa
Occupied floor pressure (tires)	304 psf	14.55 kPa
Occupied floor pressure (TraX)	100.64 psf	4.82 kPa

Sound and Vibration Levels

Sound Pressure level (ground workstation)	85 dBA
Sound Pressure level (platform workstation)	75 dBA
Vibrations	< 2.5 m/s ²

(1) The metric equivalent of working height adds 2 m to platform height. The imperial equivalent adds 6 ft to platform height.

(2) Gradeability applies to driving on slopes and may vary depending on options and machine configurations. See operator's manual for details regarding slope ratings.

(3) Weight refers to standard configuration and may vary depending on options and/or country standards.

(4) Floor loading information is approximate and may vary depending on options and machine configurations. It should be used only with adequate safety factors.

Range of motion S-65 XC/S-65 TraX

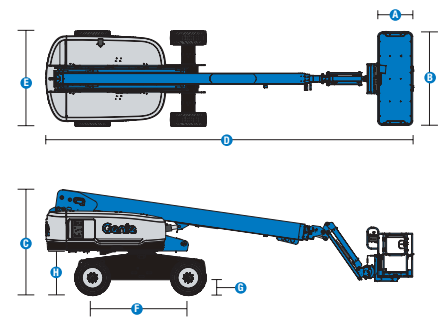
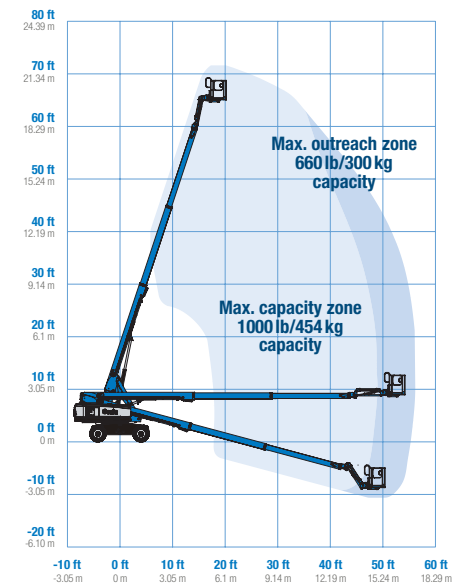

Genie® S® -65 XC™ & S-65 TraX™

SKU: Standard Model

- **S65XC001AF0002:** S-65 XC, 4WD
- **S65XC001AF0003:** S-65 XC, Lift Power 3kW, 4WD

SKU: Standard Model

- **S65XC001AF0001:** S-65 XC, Lift Power 12kW Welder Ready, 4WD
- S-65 XC, TraX, T4f, 74 hp, Deutz Turbo Diesel*

* Build to Order

Option availability	S	S+	BtO
Power			
49 hp, 37 kW, Deutz D2.9L, Diesel, T4f	✓	✓	✓
49 hp, 37 kW, Perkins 404F-E22T, Turbo Diesel, T4f			○
60 hp, 45 kW, Ford 2.5L, Gas/LPG			○
74 hp, 55 kW, Deutz TD2.9L, Turbo Diesel, T4f (TraX)			○
Cold weather package			○
Diesel air intake pre-cleaner			○
Ford engine gauge package			○
LPS Fire protection rating			○
Positive air shutdown system			○
Second battery			○
Anti-restart engine protection	✓	✓	✓
Auto engine fault shutdown	✓	✓	✓
In cylinder glow plug (diesel only)	✓	✓	✓
Platform			
6ft/1.83m dual-entry platform with side swing gate			○
8ft/2.44m tri-entry platform with side swing gate	✓	✓	✓
Dual axis joystick steering	✓	✓	✓
Thumb rocker steering			○
Air line to platform			○
Control box covers		○	○
Lift Guard Full Mesh panels			○
Lift Guard Half Mesh panels			○
Light Package: drive and work lights		○	○
Platform auxiliary top rail			○
Lift Power 3kW AC Generator, 110V/60Hz			○
Lift Power 3kW AC Generator, 220V/50Hz			○
Lift Power 12kW Welder Ready			○
660lb/300kg & 1000lb/454kg dual load capacity with automatic envelope control	✓	✓	✓
Drive enable system	✓	✓	✓
Horn	✓	✓	✓
Lift Guard Contact Alarm	✓	✓	✓
Lift Tools Work Tray	✓	✓	✓
Platform load sense system	✓	✓	✓
Proportional controls	✓	✓	✓
Self-leveling platform	✓	✓	✓
Chassis			
Lift Connect Telematics		○	○
Telematics-ready	✓	✓	✓
Lift Connect with Access Manager upgrade		○	○
Biodegradable hydraulic oil			○
Cold weather hydraulic oil			○
Fire resistant hydraulic oil			○
High floatation, air-filled tires		○	○
Rough terrain, foam-filled tires	✓	✓	✓
Rough terrain, foam-filled, non-marking tires		○	○
TraX track drive system			○
Deluxe hostile environment kit			○
Hostile environment kit			○
LPG tank 33.5 lb			○
Tow package			○
2 speed wheel motors	✓	✓	✓
Active oscillating axle	✓	✓	✓
Alarm package: includes flashing beacon and travel alarm	✓	✓	✓
Chassis tilt lift and drive function cut-out	✓	✓	✓
Descent, tilt and motion alarm	✓	✓	✓
Dual battery system	✓	✓	✓
Hour meter	✓	✓	✓
Hydraulic oil cooler	✓	✓	✓
Positive traction drive	✓	✓	✓
Tech Pro Link connector	✓	✓	✓

Positive air shutdown system for Deutz engines only

- S Standard
- S+ Standard +
- BtO Build to Order
- ✓ Standard Features
- Options



Xtra Capacity



Rugged Terrainability



Lift Power



Genie Genuine Accessories⁽¹⁾

- Lift Tools Productivity Tools
- Lift Connect Telematics
- Tech Pro Link Handheld Device

(1) More accessories available from Genie Genuine Parts.

Product specifications are subject to change without notice or obligation. Photographs and/or drawings herein are for illustrative purposes only. Refer to the appropriate Operator's Manual for instructions on proper equipment use. Failure to follow instructions in the Operator's Manual may result in serious injury or death. The only warranty applicable to our equipment is the standard written warranty applicable to the particular product and sale and we make no other warranty, express or implied. Products and services listed may be trademarks, service marks or trade names of Terex Corporation and/or their subsidiaries in the USA and many other countries. Terex, Genie, Quality By Design, Xtra Capacity, Lift Power, Lift Guard, Lift Tools, Lift Connect and Tech Pro Link are registered trademarks of Terex Corporation or its subsidiaries.



Genie® S®-65 HF

Specifications

Models	S-65 HF	
Measurements	US	Metric
Working height max.(1)	71 ft 2 in	21.86 m
Platform height max.	65 ft 2 in	19.86 m
Horizontal reach max.	51 ft 2 in	15.60 m
Below ground reach	7 ft 5 in	2.27 m
A Platform length (8 ft/6 ft)	3 ft/2 ft 6 in	0.91 m/0.76 m
B Platform width (8 ft/6 ft)	8 ft/6 ft	2.44 m/1.83 m
C Height - stowed	9 ft 4 in	2.85 m
D Length - stowed	32 ft	9.76 m
D Length - storage/transport (jib tucked under)	25 ft 7 in	7.80 m
E Width	8 ft 5 in	2.55 m
F Wheelbase	8 ft 2 in	2.50 m
G Ground clearance - center	17.3 in	0.44 m
H Height under counterweight	3 ft 11 in	1.19 m

Productivity

Lift capacity max. - unrestricted	600 lb	272 kg
Lift capacity max. - restricted	1,000 lb	454 kg
Number of Platform Occupants (restricted/unrestricted)		3/2
Platform rotation		160°
Jib length	5 ft	1.52 m
Vertical jib rotation (up/down)		133°
Turntable rotation		360°
Turntable tailswing	4 ft 6 in	1.38 m
Drive speed - stowed	3.0 mph	4.8 km/h
Drive speed - raised	0.66 ft/s	0.2 m/s
Gradeability - stowed ⁽²⁾		45%
Tilt sensor activation (front to back/side to side)		5°/5°
Turning radius - inside/outside	10 ft 10 in/18 ft 3 in	3.29 m/5.57 m
Tires		41/18LL22.5

Power

Power		Diesel
Hydraulic tank capacity	40 gal	151 L
Fuel tank capacity	35 gal	132 L

Weight(3) and Floor Loading⁽⁴⁾

Weight	24,454 lb	11,092 kg
Tire contact pressure	100 psi	690 kPa
Occupied floor pressure	281 psf	13.47 kPa

Sound and Vibration Levels

Sound Pressure level (ground workstation)	83 dBA
Sound Pressure level (platform workstation)	79 dBA
Vibrations	< 2.5 m/s ²

Range of motion S-65 HF

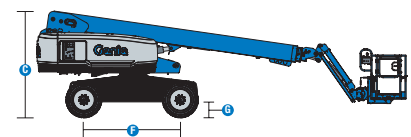
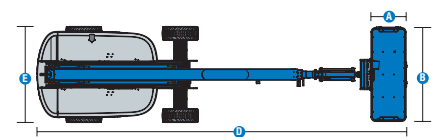
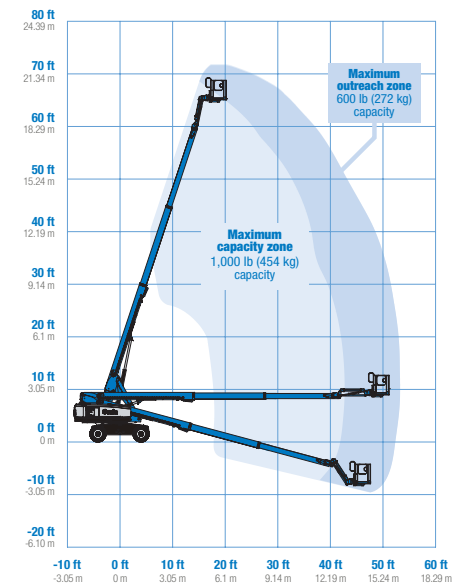

(1) The metric equivalent of working height adds 2m to platform height. The imperial equivalent adds 6ft to platform height.

(2) Gradeability applies to driving on slopes and may vary depending on options and machine configurations. See operator's manual for details regarding slope ratings.

(3) Weight refers to standard configuration and may vary depending on options and/or country standards.

(4) Floor loading information is approximate and may vary depending on options and machine configurations. It should be used only with adequate safety factors.

Genie® S® -65 HF

SKU: Standard Model

- S-65 HF, 4WD*

* Build to Order

Option availability		S	S+	BtO	
Power	49 hp, 37 kW, Perkins 404F-E22T, Turbo Diesel, T4f			<input type="radio"/>	
	60 hp, 45 kW, Ford 2.5L, Gas/LPG			<input type="radio"/>	
	74 hp, 55 kW, Deutz TD2.9L, Turbo Diesel, T4f (TRAX and HF)			<input type="radio"/>	
	Cold weather package			<input type="radio"/>	
	Diesel air intake pre-cleaner			<input type="radio"/>	
	Positive air shutdown system			<input type="radio"/>	
	Second battery			<input type="radio"/>	
	Anti-restart engine protection			<input checked="" type="checkbox"/>	
	Auto engine fault shutdown			<input checked="" type="checkbox"/>	
	In cylinder glow plug (diesel only)			<input checked="" type="checkbox"/>	
	Platform	6ft/1.83m dual-entry platform with side swing gate			<input type="radio"/>
		8ft/2.44m tri-entry platform with side swing gate			<input checked="" type="checkbox"/>
Dual axis joystick steering				<input checked="" type="checkbox"/>	
Thumb rocker steering				<input type="radio"/>	
Air line to platform				<input type="radio"/>	
Control box covers				<input type="radio"/>	
Lift Guard Full Mesh panels				<input type="radio"/>	
Lift Guard Half Mesh panels				<input type="radio"/>	
Light Package: drive and work lights				<input type="radio"/>	
Lift Power 3kW AC Generator, 110V/60Hz				<input type="radio"/>	
Lift Power 3kW AC Generator, 220V/50Hz				<input type="radio"/>	
Lift Power 12kW Welder Ready AC Generator				<input type="radio"/>	
Drive enable system				<input checked="" type="checkbox"/>	
Horn				<input checked="" type="checkbox"/>	
Lift Guard Contact Alarm				<input checked="" type="checkbox"/>	
Lift Tools Work Tray				<input checked="" type="checkbox"/>	
Platform load sense system				<input checked="" type="checkbox"/>	
Proportional controls				<input checked="" type="checkbox"/>	
Self-leveling platform			<input checked="" type="checkbox"/>		
Chassis	Lift Connect Telematics			<input checked="" type="checkbox"/>	
	Telematics-ready			<input checked="" type="checkbox"/>	
	Lift Connect with Access Manager upgrade			<input type="radio"/>	
	Biodegradable hydraulic oil			<input type="radio"/>	
	Cold weather hydraulic oil			<input type="radio"/>	
	Fire resistant hydraulic oil			<input type="radio"/>	
	High floatation, air-filled tires			<input type="radio"/>	
	Deluxe hostile environment kit			<input type="radio"/>	
	Hostile environment kit			<input type="radio"/>	
	LPG tank 33.5 lb			<input type="radio"/>	
	Tow package			<input type="radio"/>	
	Active oscillating axle			<input checked="" type="checkbox"/>	
	Alarm package: includes flashing beacon and travel alarm			<input checked="" type="checkbox"/>	
	Chassis tilt lift and drive function cut-out			<input checked="" type="checkbox"/>	
	Descent, tilt and motion alarm			<input checked="" type="checkbox"/>	
	Dual battery system			<input checked="" type="checkbox"/>	
Hour meter			<input checked="" type="checkbox"/>		
Hydraulic oil cooler			<input checked="" type="checkbox"/>		
Tech Pro Link connector			<input checked="" type="checkbox"/>		

Positive air shutdown system for Deutz engines only

- S Standard
- S+ Standard +
- BtO Build to Order
- ✓ Standard Features
- Options



Sensitive Terrains



Dual Capacity



Lift Power



Genie Genuine Accessories⁽¹⁾

- Lift Tools Productivity Tools
- Lift Connect Telematics
- Tech Pro Link Handheld Device

(1) More accessories available from Genie Genuine Parts.

Product specifications are subject to change without notice or obligation. Photographs and/or drawings herein are for illustrative purposes only. Refer to the appropriate Operator's Manual for instructions on proper equipment use. Failure to follow instructions in the Operator's Manual may result in serious injury or death. The only warranty applicable to our equipment is the standard written warranty applicable to the particular product and sale and we make no other warranty, express or implied. Products and services listed may be trademarks, service marks or trade names of Terex Corporation and/or their subsidiaries in the USA and many other countries. Terex, Genie, Quality By Design, Xtra Capacity, Lift Power, Lift Guard, Lift Tools, Lift Connect and Tech Pro Link are registered trademarks of Terex Corporation or its subsidiaries.

09/24



Genie® S®-85 XC™

Specifications

Models	S-85 XC	
Measurements	US	Metric
Working height max. ⁽¹⁾	91 ft	27.91 m
Platform height max.	85 ft	25.91 m
Horizontal reach max.	74 ft 6 in	22.71 m
Below ground reach	8 ft 8 in	2.64 m
A Platform length (8 ft/6 ft)	3 ft/2 ft 6 in	0.91 m/0.76 m
B Platform width (8 ft/6 ft)	8 ft/6 ft	2.44 m/1.83 m
C Height - stowed	9 ft 2 in	2.80 m
D Length - stowed	40 ft 7 in	12.37 m
D Length - storage/transport (jib tucked under)	33 ft 8 in	10.25 m
E Width	8 ft 2 in	2.49 m
F Wheelbase	9 ft 4 in	2.85 m
G Ground clearance - center	15.8 in	0.40 m
H Height under counterweight	3 ft 9 in	1.14 m

Productivity

Lift capacity max. - unrestricted	660 lb	300 kg
Lift capacity max. - restricted	1,000 lb	454 kg
Number of Platform Occupants (restricted/unrestricted)		3/2
Platform rotation		160°
Jib length	5 ft	1.52 m
Vertical jib rotation (up/down)		133°
Turntable rotation		360°
Turntable tailswing	5 ft 3 in	1.60 m
Drive speed - stowed	3.0 mph	4.8 km/h
Drive speed - raised	0.5 mph	0.2 m/s
Gradeability - stowed ⁽²⁾		45%
Tilt sensor activation (front to back/side to side)		7°/5°
Turning radius - inside/outside	12 ft/21 ft 6 in	3.66 m/6.55 m
Tires		18-625

Power

Power		Diesel
Hydraulic tank capacity	40 gal	150 L
Fuel tank capacity	35 gal	132 L

Weight⁽³⁾ and Floor Loading⁽⁴⁾

Weight	39,500 lb	17,917 kg
Tire contact pressure	130 psi	896 kPa
Occupied floor pressure	395 psf	18.9 kPa

Sound and Vibration Levels

Sound Pressure level (ground workstation)	85 dBA
Sound Pressure level (platform workstation)	78 dBA
Vibrations	< 2.5 m/s ²

Range of motion S-85 XC

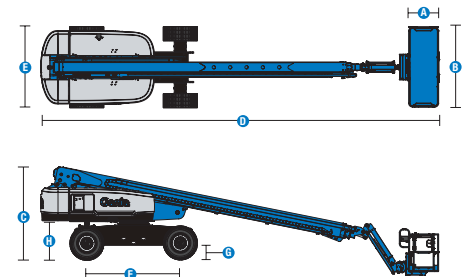
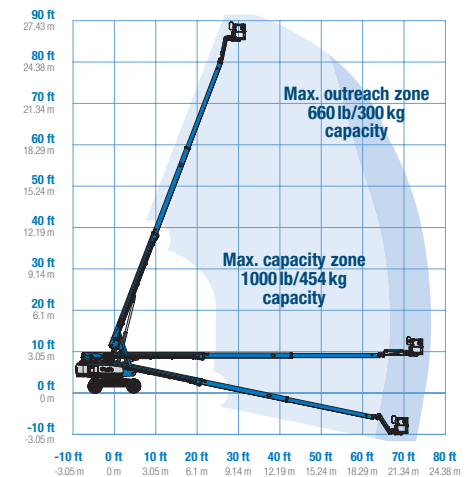

(1) The metric equivalent of working height adds 2 m to platform height. The imperial equivalent adds 6 ft to platform height.

(2) Gradeability applies to driving on slopes and may vary depending on options and machine configurations. See operator's manual for details regarding slope ratings.

(3) Weight refers to standard configuration and may vary depending on options and/or country standards.

(4) Floor loading information is approximate and may vary depending on options and machine configurations. It should be used only with adequate safety factors.

Genie® S®-85 XC™

SKU: Standard Model

- **S85XC001AF0003:** S-85 XC, 4WD
- **S85XC001AF0006:** S-85 XC, Lift Power 3kW, 4WD
- **S85XC001AF0002:** S-85 XC, Lift Power 12kW Welder Ready, 4WD

* Build to Order

Option availability	S	S+	BtO
Power			
74 hp, 55 kW, Deutz TD2.9L, Turbo Diesel, T4f (TRAX and 80/85)	✓	✓	✓
Cold weather package			○
Diesel air intake pre-cleaner			○
Positive air shutdown system			○
Second battery			○
Anti-restart engine protection	✓	✓	✓
Auto engine fault shutdown	✓	✓	✓
In cylinder glow plug (diesel only)	✓	✓	✓
Platform			
6ft/1.83m dual-entry platform with side swing gate			○
8ft/2.44m tri-entry platform with side swing gate	✓	✓	✓
Dual axis joystick steering	✓	✓	✓
Thumb rocker steering			○
Air line to platform			○
Control box covers		○	○
Lift Guard Full Mesh panels			○
Lift Guard Half Mesh panels			○
Light Package: drive and work lights		○	○
Platform auxiliary top rail			○
Lift Power 3kW AC Generator, 110V/60Hz			○
Lift Power 3kW AC Generator, 220V/50Hz			○
Lift Power 12kW Welder Ready			○
660lb/300kg & 1000lb/454kg dual load capacity with automatic envelope control	✓	✓	✓
Drive enable system	✓	✓	✓
Horn	✓	✓	✓
Lift Guard Contact Alarm	✓	✓	✓
Lift Tools Work Tray	✓	✓	✓
Platform load sense system	✓	✓	✓
Proportional controls	✓	✓	✓
Self-leveling platform	✓	✓	✓
Chassis			
Lift Connect Telematics	✓	✓	✓
Telematics-ready	✓	✓	✓
Lift Connect with Access Manager upgrade		○	○
Biodegradable hydraulic oil			○
Cold weather hydraulic oil			○
Fire resistant hydraulic oil			○
High floatation, air-filled tires		○	○
Rough terrain, foam-filled tires	✓	✓	✓
Rough terrain, foam-filled, non-marking tires		○	○
Deluxe hostile environment kit			○
Hostile environment kit			○
LPG tank 33.5 lb			○
Tow package			○
2 speed wheel motors	✓	✓	✓
Active oscillating axle	✓	✓	✓
Alarm package: includes flashing beacon and travel alarm	✓	✓	✓
Chassis tilt lift and drive function cut-out	✓	✓	✓
Descent, tilt and motion alarm	✓	✓	✓
Dual battery system	✓	✓	✓
Hour meter	✓	✓	✓
Hydraulic oil cooler	✓	✓	✓
Tech Pro Link connector	✓	✓	✓

Positive air shutdown system for Deutz engines only

- S Standard
- S+ Standard +
- BtO Build to Order
- ✓ Standard Features
- Options



Xtra Capacity



Rugged Terrainability



Lift Power

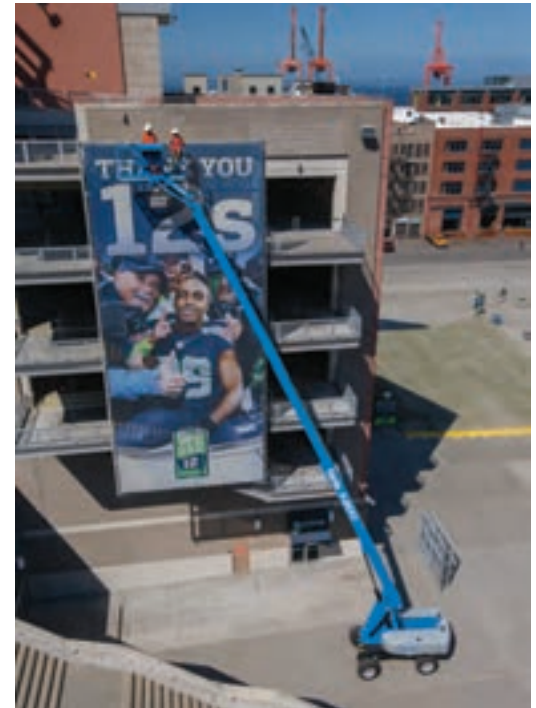

Genie Genuine Accessories⁽¹⁾

- Lift Tools Productivity Tools
- Lift Connect Telematics
- Tech Pro Link Handheld Device

(1) More accessories available from Genie Genuine Parts.

Product specifications are subject to change without notice or obligation. Photographs and/or drawings herein are for illustrative purposes only. Refer to the appropriate Operator's Manual for instructions on proper equipment use. Failure to follow instructions in the Operator's Manual may result in serious injury or death. The only warranty applicable to our equipment is the standard written warranty applicable to the particular product and sale and we make no other warranty, express or implied. Products and services listed may be trademarks, service marks or trade names of Terex Corporation and/or their subsidiaries in the USA and many other countries. Terex, Genie, Quality By Design, Xtra Capacity, Lift Power, Lift Guard, Lift Tools, Lift Connect and Tech Pro Link are registered trademarks of Terex Corporation or its subsidiaries.

09/23



Genie® S®-85 XC™ FE & S-85 XC E

Specifications

Models	S-85 XC FE & S-85 XC E	
Measurements	US	Metric
Working height max.(1)	91 ft	27.91 m
Platform height max.	85 ft	25.91 m
Horizontal reach max.	74 ft 6 in	22.71 m
Below ground reach	8 ft 8 in	2.64 m
A Platform length (8 ft/6 ft)	3 ft/2 ft 6 in	0.91 m/0.76 m
B Platform width (8 ft/6 ft)	8 ft/6 ft	2.44 m/1.83 m
C Height - stowed	9 ft 4 in	2.84 m
D Length - stowed	41 ft 9 in	12.37 m
D Length - storage/transport (jib tucked under)	34 ft 6 in	10.51 m
E Width	8 ft 2 in	2.49 m
F Wheelbase	10 ft	3.05 m
G Ground clearance - center	16.8 in	0.42 m
H Height under counterweight	3 ft 11 in	1.19 m

Productivity

Lift capacity max. - unrestricted	660 lb	300 kg
Lift capacity max. - restricted	1,000 lb	454 kg
Number of Platform Occupants (restricted/unrestricted)		3/2
Platform rotation		160°
Jib length	5 ft	1.52 m
Vertical jib rotation (up/down)		133°
Turntable rotation		360°
Turntable tailswing	5 ft 9 in	1.75 m
Drive speed - stowed	3.0 mph	4.8 km/h
Drive speed - raised	0.5 mph	0.2 m/s
Gradeability - stowed ⁽²⁾		45%
Tilt sensor activation (front to back/side to side)		7°/5°
Turning radius - inside/outside	11 ft 6 in/22 ft 3 in	3.50 m/6.78 m
Tires		18-710

Power

Drive System	48V 3-Phase AC	
Battery Pack, Electric (high capacity)	48V DC (8×6V), Li-ion	
Battery Pack, Hybrid (standard capacity)	48V DC (8×6V), Li-ion	
AC generator, Hybrid	Diesel	
Auxiliary power unit, Hybrid	48V DC (4×12V)	
Hydraulic tank capacity	28 gal	106 L
Fuel tank capacity	17 gal	64 L

Weight(3) and Floor Loading⁽⁴⁾

Weight, Electric	38,908 lb	17,648 kg
Weight, Hybrid	39,592 lb	17,958 kg
Tire contact pressure	198 psi	1365 kPa
Occupied floor pressure	395 psf	18.9 kPa

Sound and Vibration Levels

Sound Pressure level (ground workstation), Electric/Hybrid	< 70 dBA/83 dBA	
Sound Pressure level (platform workstation), Electric/Hybrid	< 70 dBA/72 dBA	
Vibrations	1.15 ft/s ²	0.35 m/s ²

Range of motion S-85 XC

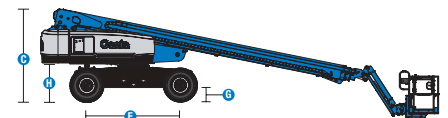
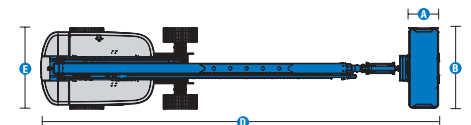
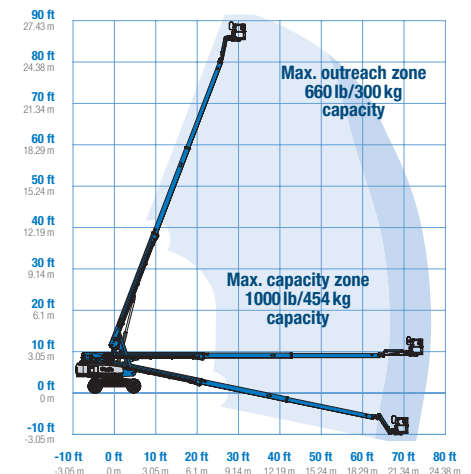

(1) The metric equivalent of working height adds 2m to platform height. The imperial equivalent adds 6ft to platform height.

(2) Gradeability applies to driving on slopes and may vary depending on options and machine configurations. See operator's manual for details regarding slope ratings.

(3) Weight refers to standard configuration and may vary depending on options and/or country standards.

(4) Floor loading information is approximate and may vary depending on options and machine configurations. It should be used only with adequate safety factors.

Genie® S® -85 XC™ FE & S-85 XC E

SKU: Standard Model

- **S85XCFE1AG0009:** S-85 XC FE, Hybrid, Std. Lithium Battery, 4WD, RT FF tires
- **S85XCFE1AG0010:** S-85 XC FE, Hybrid, Std. Lithium Battery, 4WD, RT FF tires, 12kW Lift Power

* Build to Order

SKU: Standard Model

- **S85XCE01AE0001:** S-85 XC E, Electric, XC Lithium Battery, 4WD, RT FF tires
- **S85XCE01AE0002:** S-85 XC E, Electric, XC Lithium Battery, 4WD, RT FF tires, 12kW Lift Power

Option availability	S	S+	BtO
Power			
24.8 hp, 18.5kW, Kubota D1105, Diesel, T4i/T4f, Stage IIIA/IV, CN IV (Hybrid model only)	✓	✓	✓
Lithium-Ion Maintenance-Free Battery	✓	✓	✓
48V solid state battery charger 1.2kW (Standard on Hybrid)	✓	✓	✓
48V solid state battery charger 3.3kW (Standard on Electric)*	✓	✓	✓
EVSE: electric vehicle charging port		○	○
Power inverter 3kW 120V/60Hz		○	○
3-phase AC drive system	✓	✓	✓
48V DC auxiliary power unit	✓	✓	✓
Charge Port NMA 5-15	✓	✓	✓
Low voltage interrupt (LVI) with battery charge indicator (BCI)	✓	✓	✓
Platform			
6ft/1.83m dual-entry platform with side swing gate			○
8ft/2.44m tri-entry platform with side swing gate	✓	✓	✓
Power to platform, US Plug	✓	✓	✓
Dual axis joystick steering	✓	✓	✓
Air line to platform			○
Control box covers		○	○
Lift Guard Full Mesh panels			○
Lift Guard Half Mesh panels			○
Light Package: drive and work lights		○	○
Platform auxiliary top rail			○
Lift Power 12kW Welder Ready AC Generator			○
660lb/300kg & 1000lb/454kg dual load capacity with automatic envelope control	✓	✓	✓
AC Power cord to platform	✓	✓	✓
Drive enable system	✓	✓	✓
Horn	✓	✓	✓
Lift Guard Contact Alarm	✓	✓	✓
Lift Tools Work Tray	✓	✓	✓
Platform load sense system	✓	✓	✓
Proportional controls	✓	✓	✓
Self-leveling platform	✓	✓	✓
Chassis			
Telematics-ready connector	✓	✓	✓
Lift Connect Telematics		○	○
Lift Connect with Access Manager upgrade		○	○
Biodegradable hydraulic oil			○
Cold weather hydraulic oil			○
Fire resistant hydraulic oil			○
Rough terrain, foam-filled tires	✓	✓	✓
Rough terrain, foam-filled, non-marking tires		○	○
Cold Start Package (Kubota)			○
Lift Guard White Noise Alarm		○	○
Hostile environment kit			○
Lift Tools Panel Cradle			✓
Active oscillating axle	✓	✓	✓
Alarm package: flashing beacons, descent, travel and tilt alarms	✓	✓	✓
Chassis tilt drive function cut-out	✓	✓	✓
Chassis tilt lift and drive function cut-out	✓	✓	✓
Descent, tilt and motion alarm	✓	✓	✓
Electric brake release	✓	✓	✓
Hour meter	✓	✓	✓
On-board diagnostic system	✓	✓	✓
Tech Pro Link connector	✓	✓	✓

*Optional on Hybrid when equipped with XC Battery

- S Standard
- S+ Standard +
- BtO Build to Order
- ✓ Standard Features
- Options



Xtra Capacity



Low Noise, Low Emissions



Lift Power



Genie Genuine Accessories⁽¹⁾

- Lift Tools Productivity Tools
- Lift Connect Telematics
- Tech Pro Link Handheld Device

(1) More accessories available from Genie Genuine Parts.

Product specifications are subject to change without notice or obligation. Photographs and/or drawings herein are for illustrative purposes only. Refer to the appropriate Operator's Manual for instructions on proper equipment use. Failure to follow instructions in the Operator's Manual may result in serious injury or death. The only warranty applicable to our equipment is the standard written warranty applicable to the particular product and sale and we make no other warranty, express or implied. Products and services listed may be trademarks, service marks or trade names of Terex Corporation and/or their subsidiaries in the USA and many other countries. Terex, Genie, Quality By Design, Xtra Capacity, Lift Power, Lift Guard, Lift Tools, Lift Connect and Tech Pro Link are registered trademarks of Terex Corporation or its subsidiaries.

Genie® S®-85 HF

Specifications

Models	S-85 HF	
Measurements	US	Metric
Working height max.(1)	91 ft	27.91 m
Platform height max.	85 ft	25.91 m
Horizontal reach max.	72 ft 6 in	22.10 m
Below ground reach	8 ft 8 in	2.64 m
A Platform length (8 ft/6 ft)	3 ft/2 ft 6 in	0.91 m/0.76 m
B Platform width (8 ft/6 ft)	8 ft/6 ft	2.44 m/1.83 m
C Height - stowed	9 ft 2 in	2.80 m
D Length - stowed	40 ft 7 in	12.37 m
D Length - storage/transport (jib tucked under)	33 ft 8 in	10.25 m
E Width	8 ft 6 in	2.59 m
F Wheelbase	9 ft 4 in	2.85 m
G Ground clearance - center	15.8 in	0.40 m
H Height under counterweight	3 ft 7 in	

Productivity

Lift capacity max. - unrestricted	600 lb	272 kg
Lift capacity max. - restricted	1,000 lb	454 kg
Number of Platform Occupants	2	
Platform rotation	160°	
Jib length	5 ft	1.52 m
Vertical jib rotation (up/down)	133°	
Turntable rotation	360°	
Turntable tailswing	5 ft 3 in	1.6 m
Drive speed - stowed	3.0 mph	4.8 km/h
Drive speed - raised	0.5 mph	0.2 m/s
Gradeability - stowed ⁽²⁾	45%	
Tilt sensor activation (front to back/side to side)	7°/5°	
Turning radius - inside/outside	12 ft/21 ft 6 in	3.66 m/6.55 m
Tires	41/18LL22.5	

Power

Power	Diesel	
Hydraulic tank capacity	40 gal	150 L
Fuel tank capacity	35 gal	132 L

Weight(3) and Floor Loading⁽⁴⁾

Weight	38,000 lb	17,237 kg
Tire contact pressure	100 psi	689.47 kPa
Occupied floor pressure	366 psf	17.53 kPa

Sound and Vibration Levels

Sound Pressure level (ground workstation)	85 dBA	
Sound Pressure level (platform workstation)	78 dBA	
Vibrations	< 2.5 m/s ²	< 2.5 m/s ²

Range of motion S-85 HF

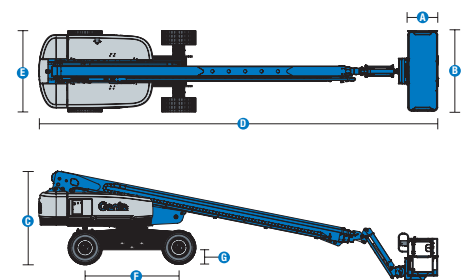
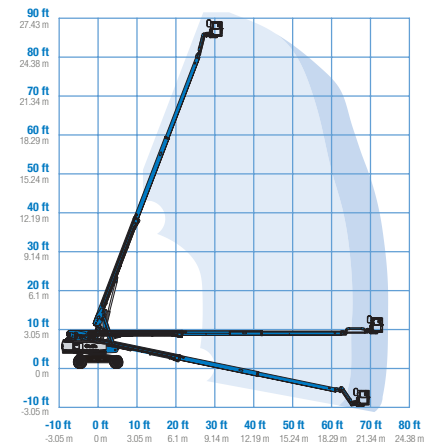

(1) The metric equivalent of working height adds 2m to platform height. The imperial equivalent adds 6ft to platform height.

(2) Gradeability applies to driving on slopes and may vary depending on options and machine configurations. See operator's manual for details regarding slope ratings.

(3) Weight refers to standard configuration and may vary depending on options and/or country standards.

(4) Floor loading information is approximate and may vary depending on options and machine configurations. It should be used only with adequate safety factors.

Genie® S®-85 HF

SKU: Standard Model

- S-85 HF, 4WD*

* Build to Order

Option availability		S	S+	BtO
Power	74 hp, 55 kW, Deutz TD2.9L, Turbo Diesel, T4f (TRAX and 80/85)			<input type="radio"/>
	Cold weather package			<input type="radio"/>
	Diesel air intake pre-cleaner			<input type="radio"/>
	Anti-restart engine protection			<input checked="" type="checkbox"/>
	Auto engine fault shutdown			<input checked="" type="checkbox"/>
	In cylinder glow plug (diesel only)			<input checked="" type="checkbox"/>
	Platform	6ft/1.83m dual-entry platform with side swing gate		
8ft/2.44m tri-entry platform with side swing gate				<input checked="" type="checkbox"/>
Dual axis joystick steering				<input checked="" type="checkbox"/>
Thumb rocker steering				<input type="radio"/>
Air line to platform				<input type="radio"/>
Control box covers				<input type="radio"/>
Lift Guard Full Mesh panels				<input type="radio"/>
Lift Guard Half Mesh panels				<input type="radio"/>
Light Package: drive and work lights				<input type="radio"/>
Platform auxiliary top rail				<input type="radio"/>
Lift Power 3kW AC Generator, 110V/60Hz				<input type="radio"/>
Lift Power 3kW AC Generator, 220V/50Hz				<input type="radio"/>
Lift Power 12kW Welder Ready AC Generator				<input type="radio"/>
600lb/300kg unrestricted platform capacity				<input checked="" type="checkbox"/>
Drive enable system				<input checked="" type="checkbox"/>
Horn				<input checked="" type="checkbox"/>
Lift Guard Contact Alarm				<input checked="" type="checkbox"/>
Lift Tools Work Tray				<input checked="" type="checkbox"/>
Platform load sense system				<input checked="" type="checkbox"/>
Proportional controls				<input checked="" type="checkbox"/>
Self-leveling platform			<input checked="" type="checkbox"/>	
Chassis	Lift Connect Telematics			<input checked="" type="checkbox"/>
	Telematics-ready			<input checked="" type="checkbox"/>
	Lift Connect with Access Manager upgrade			<input type="radio"/>
	Biodegradable hydraulic oil			<input type="radio"/>
	Cold weather hydraulic oil			<input type="radio"/>
	Fire resistant hydraulic oil			<input type="radio"/>
	High floatation, air-filled tires			<input type="radio"/>
	Deluxe hostile environment kit			<input type="radio"/>
	Hostile environment kit			<input type="radio"/>
	Positive air shutdown system			<input type="radio"/>
	LPG tank 33.5 lb			<input type="radio"/>
	Tow package			<input type="radio"/>
	Active oscillating axle			<input checked="" type="checkbox"/>
	Alarm package: includes flashing beacon and travel alarm			<input checked="" type="checkbox"/>
	Chassis tilt lift and drive function cut-out			<input checked="" type="checkbox"/>
	Descent, tilt and motion alarm			<input checked="" type="checkbox"/>
	Dual battery system			<input checked="" type="checkbox"/>
	Hour meter			<input checked="" type="checkbox"/>
Hydraulic oil cooler			<input checked="" type="checkbox"/>	
Tech Pro Link connector			<input checked="" type="checkbox"/>	

Positive air shutdown system for Deutz engines only

- S Standard
- S+ Standard +
- BtO Build to Order
- Standard Features
- Options



Sensitive Terrains



Dual Capacity



Lift Power



Genie Genuine Accessories⁽¹⁾

- Lift Tools Productivity Tools
- Lift Connect Telematics
- Tech Pro Link Handheld Device

(1) More accessories available from Genie Genuine Parts.

Product specifications are subject to change without notice or obligation. Photographs and/or drawings herein are for illustrative purposes only. Refer to the appropriate Operator's Manual for instructions on proper equipment use. Failure to follow instructions in the Operator's Manual may result in serious injury or death. The only warranty applicable to our equipment is the standard written warranty applicable to the particular product and sale and we make no other warranty, express or implied. Products and services listed may be trademarks, service marks or trade names of Terex Corporation and/or their subsidiaries in the USA and many other countries. Terex, Genie, Quality By Design, Xtra Capacity, Lift Power, Lift Guard, Lift Tools, Lift Connect and Tech Pro Link are registered trademarks of Terex Corporation or its subsidiaries.

09/24



Genie® SX™ -125 XC™

Specifications

Models	SX-125 XC	
Measurements	US	Metric
Working height max. ⁽¹⁾	131 ft	40,10 m
Platform height max.	125 ft	38,10 m
Horizontal reach max.	80 ft	24,38 m
Below ground reach	8 ft 10 in	2,69 m
A Platform length (8 ft/6 ft)	3 ft/2 ft 6 in	0,91 m/0,76 m
B Platform width (8 ft/6 ft)	8 ft/6 ft	2,44 m/1,83 m
C Height - stowed	10 ft	3,05 m
D Length - stowed	46 ft 9 in	14,25 m
D Length - storage/transport (jib tucked under)	40 ft	12,19 m
E Width (axles retracted)	8 ft 2 in	2,49 m
E Width (axles extended)	12 ft 11 in	3,94 m
F Wheelbase	13 ft 6 in	4,11 m
G Ground clearance - center	15 in	0,38 m
H Height under counterweight	4 ft	1,22 m

Productivity

Lift capacity max. - unrestricted	660 lb	300 kg
Lift capacity max. - restricted	1 000 lb	454 kg
Number of Platform Occupants (restricted/unrestricted)		3/2
Platform rotation		160°
Jib length	5 ft	1,52 m
Vertical jib rotation (up/down)		135°
Turntable rotation		360°
Turntable tailswing (axles retracted)	1 ft 10 in	0,56 m
Turntable tailswing (axles extended)	3 ft 4 in	1,02 m
Drive speed - stowed	3,0 mph	4,9 km/h
Drive speed - raised	0,38 mph	0,6 km/h
Gradeability - stowed ⁽²⁾		40%
Tilt sensor activation (front to back/side to side)		4,5° / 4,5°
Turning radius - inside/outside (axle retracted)	26 ft 4 in/32 ft 8 in	8,03 m/9,96 m
Turning radius - inside/outside (axle extended)	9 ft 6 in/20 ft 3 in	2,90 m/6,17 m
Tires	445D50/710	

Power

Power	Diesel	
Hydraulic tank capacity	55 gal	208 L
Fuel tank capacity	40 gal	151 L

Weight⁽³⁾ and Floor Loading⁽⁴⁾

Weight	45 636 lb	20 700 kg
Tire contact pressure	102 psi	700 kPa
Occupied floor pressure, axles retracted/ extended	324 psf/ 205 psf	15,52 kPa/ 9,81 kPa

Sound and Vibration Levels

Sound Pressure level (ground workstation)	91 dBA
Sound Pressure level (platform workstation)	75 dBA
Vibrations	< 2,5 m/s ²

Range of motion SX-125 XC

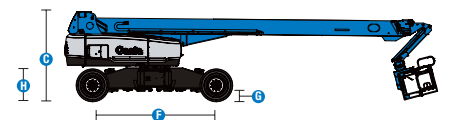
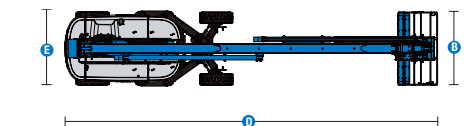
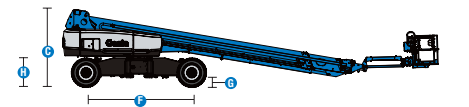
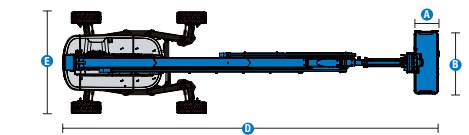
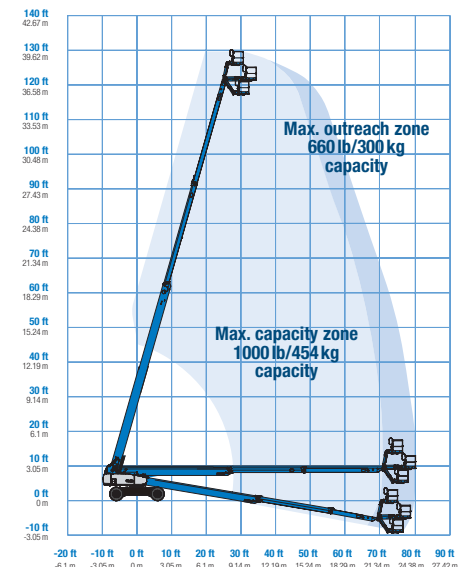

(1) The metric equivalent of working height adds 2m to platform height. The imperial equivalent adds 6ft to platform height.

(2) Gradeability applies to driving on slopes and may vary depending on options and machine configurations. See operator's manual for details regarding slope ratings.

(3) Weight refers to standard configuration and may vary depending on options and/or country standards.

(4) Floor loading information is approximate and may vary depending on options and machine configurations. It should be used only with adequate safety factors.

Genie® SX™ -125 XC™

SKU: Standard Model

- SX-125 XC, 4WD*
- **SX125XC1AF0043:** SX-125 XC, 12kW Welder Ready, 4WD
- **SX125XC1AF0044:** SX-125 XC, 12kW Welder Ready, Cold weather package, 4WD

* Build to Order

Option availability	S	S+	BtO
Power			
74 hp, 55 kW, Deutz TD2.9L, Turbo Diesel, T4f			○
Cold weather package			○
Diesel air intake pre-cleaner			○
Positive air shutdown system			○
Anti-restart engine protection	✓	✓	✓
Auto engine fault shutdown	✓	✓	✓
In cylinder glow plug (diesel only)	✓	✓	✓
Platform			
6ft/1,83m dual-entry platform with side swing gate			○
8ft/2,44m tri-entry platform with side swing gate	✓	✓	✓
Dual axis joystick steering	✓	✓	✓
Thumb rocker steering			○
Air line to platform			○
Control box covers		○	○
Lift Guard Full Mesh panels			○
Lift Guard Half Mesh panels			○
Light Package: drive and work lights		○	○
Platform auxiliary top rail			○
4 Steering modes	✓	✓	✓
660lb/300kg & 1000lb/454kg dual load capacity with automatic envelope control	✓	✓	✓
Drive enable system	✓	✓	✓
Horn	✓	✓	✓
Lift Guard Contact Alarm	✓	✓	✓
Lift Tools Work Tray	✓	✓	✓
Platform load sense system	✓	✓	✓
Proportional controls	✓	✓	✓
Self-leveling platform	✓	✓	✓
Chassis			
Lift Connect Telematics	✓	✓	✓
Telematics-ready	✓	✓	✓
Lift Connect with Access Manager upgrade		○	○
Biodegradable hydraulic oil			○
Cold weather hydraulic oil			○
Fire resistant hydraulic oil			○
Rough terrain, foam-filled tires	✓	✓	✓
Hostile environment kit			○
2 speed wheel motors	✓	✓	✓
Alarm package: includes flashing beacon and travel alarm	✓	✓	✓
Chassis tilt lift and drive function cut-out	✓	✓	✓
Descent, tilt and motion alarm	✓	✓	✓
Dual battery system	✓	✓	✓
Hour meter	✓	✓	✓
Hydraulic oil cooler	✓	✓	✓
Mini XChassis extendable axles	✓	✓	✓
Tech Pro Link connector	✓	✓	✓

- S Standard
- S+ Standard +
- BtO Build to Order
- ✓ Standard Features
- Options



Xtra Capacity



Mini XChassis



Smooth Envelope



Genie Genuine Accessories⁽¹⁾

- Lift Tools Productivity Tools
- Lift Connect Telematics
- Tech Pro Link Handheld Device

(1) More accessories available from Genie Genuine Parts.

Product specifications are subject to change without notice or obligation. Photographs and/or drawings herein are for illustrative purposes only. Refer to the appropriate Operator's Manual for instructions on proper equipment use. Failure to follow instructions in the Operator's Manual may result in serious injury or death. The only warranty applicable to our equipment is the standard written warranty applicable to the particular product and sale and we make no other warranty, express or implied. Products and services listed may be trademarks, service marks or trade names of Terex Corporation and/or their subsidiaries in the USA and many other countries. Terex, Genie, Quality By Design, Xtra Capacity, Lift Power, Lift Guard, Lift Tools, Lift Connect and Tech Pro Link are registered trademarks of Terex Corporation or its subsidiaries.

07/24

Genie® SX™ -135 XC™

Specifications

Models	SX-135 XC	
Measurements	US	Metric
Working height max. ⁽¹⁾	141 ft	43.15 m
Platform height max.	135 ft	41.15 m
Horizontal reach max.	90 ft	27.43 m
Below ground reach	19 ft 8 in	6.00 m
A Platform length	3 ft	0.91 m
B Platform width	8 ft	2.44 m
C Height - stowed	10 ft	3.05 m
D Length - stowed	64 ft 10 in	19.76 m
D Length - storage/transport (jib tucked under)	43 ft 7 in	13.28 m
E Width (axles retracted)	8 ft 2 in	2.49 m
E Width (axles extended)	12 ft 11 in	3.94 m
F Wheelbase (axles retracted)	13 ft 6 in	4.11 m
F Wheelbase (axles extended)	13 ft 6 in	4.11 m
G Ground clearance - center	15 in	0.38 m
H Height under counterweight	4 ft 1 in	1.24 m

Productivity

Lift capacity max. - unrestricted	660 lb	300 kg
Lift capacity max. - restricted	1,000 lb	454 kg
Number of Platform Occupants (restricted/unrestricted)	3/2	
Platform rotation	160°	
Jib length	18/30 ft	5.48/9.14 m
Vertical jib rotation (up/down)	130°	
Turntable rotation	360°	
Turntable tailswing (axles retracted)	3 ft 9 in	1.14 m
Turntable tailswing (axles extended)	5 ft 7 in	1.70 m
Drive speed - stowed	2.7 mph	4.3 km/h
Drive speed - raised	0.4 mph	0.65 km/h
Gradeability - stowed ⁽²⁾	35%	
Tilt sensor activation (front to back/side to side)	4.5° / 4.5°	
Turning radius - inside/outside (axle retracted)	26 ft 4 in/32 ft 8 in	8.03 m/9.96 m
Turning radius - inside/outside (axle extended)	9 ft 6 in/20 ft 3 in	2.90 m/6.17 m
Tires	445D50/710	

Power

Power	Diesel	
Hydraulic tank capacity	60 gal	227 L
Fuel tank capacity	40 gal	151 L

Weight⁽³⁾ and Floor Loading⁽⁴⁾

Weight	46,900 lb	21,273 kg
Tire contact pressure	130 psi	896 kPa
Occupied floor pressure, axles retracted/ extended	351 psf/ 222 psf	16.79 kPa/ 10.62 kPa

Sound and Vibration Levels

Sound Pressure level (ground workstation)	91 dBA
Sound Pressure level (platform workstation)	75 dBA
Vibrations	< 2.5 m/s ²

Range of motion SX-135 XC

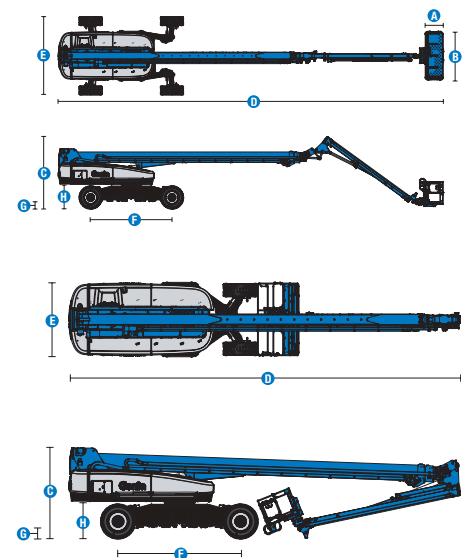
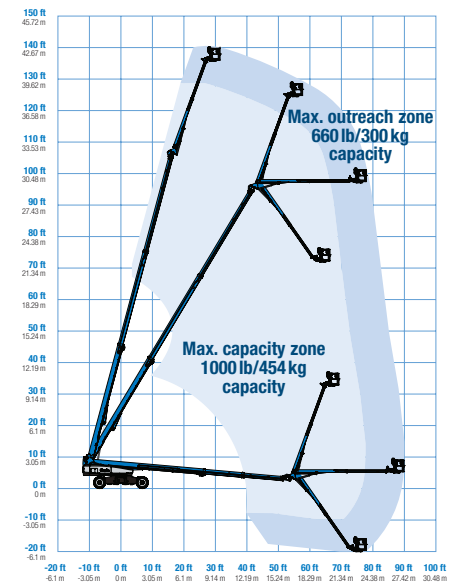

(1) The metric equivalent of working height adds 2 m to platform height. The imperial equivalent adds 6 ft to platform height.

(2) Gradeability applies to driving on slopes and may vary depending on options and machine configurations. See operator's manual for details regarding slope ratings.

(3) Weight refers to standard configuration and may vary depending on options and/or country standards.

(4) Floor loading information is approximate and may vary depending on options and machine configurations. It should be used only with adequate safety factors.

Genie® SX™ -135 XC™

SKU: Standard Model

- **SX135XC1AF0028:** SX-135 XC, 4WD
- **SX135XC1AF0029:** SX-135 XC, 12kW Welder Ready, 4WD

* Build to Order

Option availability	S	S+	BtO
Power			
74 hp, 55 kW, Deutz TD2.9L, Turbo Diesel, T4f	✓	✓	✓
Cold weather package			○
Diesel air intake pre-cleaner			○
Positive air shutdown system			○
Anti-restart engine protection	✓	✓	✓
Auto engine fault shutdown	✓	✓	✓
In cylinder glow plug (diesel only)	✓	✓	✓
Platform			
6ft/1.83m dual-entry platform with side swing gate			○
8ft/2.44m tri-entry platform with side swing gate	✓	✓	✓
Dual axis joystick steering	✓	✓	✓
Thumb rocker steering			○
Air line to platform			○
Control box covers		○	○
Lift Guard Full Mesh panels			○
Lift Guard Half Mesh panels			○
Light Package: drive and work lights		○	○
Platform auxiliary top rail			○
3kW AC Generator, 110V/50Hz			○
3kW AC Generator, 220V/50Hz			○
12kW Welder Ready			○
4 Steering modes	✓	✓	✓
660lb/300kg & 1000lb/454kg dual load capacity with automatic envelope control	✓	✓	✓
Drive enable system	✓	✓	✓
Horn	✓	✓	✓
Lift Guard Contact Alarm	✓	✓	✓
Lift Tools Work Tray	✓	✓	✓
Platform load sense system	✓	✓	✓
Proportional controls	✓	✓	✓
Self-leveling platform	✓	✓	✓
Chassis			
Lift Connect Telematics	✓	✓	✓
Telematics-ready	✓	✓	✓
Lift Connect with Access Manager upgrade		○	○
Biodegradable hydraulic oil			○
Cold weather hydraulic oil			○
Fire resistant hydraulic oil			○
Rough terrain, foam-filled tires	✓	✓	✓
Hostile environment kit			○
2 speed wheel motors	✓	✓	✓
Alarm package: includes flashing beacon and travel alarm	✓	✓	✓
Chassis tilt lift and drive function cut-out	✓	✓	✓
Descent, tilt and motion alarm	✓	✓	✓
Dual battery system	✓	✓	✓
Hour meter	✓	✓	✓
Hydraulic oil cooler	✓	✓	✓
Mini XChassis extendable axles	✓	✓	✓
Tech Pro Link connector	✓	✓	✓

- S Standard
- S+ Standard +
- BtO Build to Order
- ✓ Standard Features
- Options



Jib-Extend
18-30ft/5.48-9.14m



Outreach > 90ft/27m



Mini XChassis



Genie Genuine Accessories⁽¹⁾

- Lift Tools Productivity Tools
- Lift Connect Telematics
- Tech Pro Link Handheld Device

(1) More accessories available from Genie Genuine Parts.

Product specifications are subject to change without notice or obligation. Photographs and/or drawings herein are for illustrative purposes only. Refer to the appropriate Operator's Manual for instructions on proper equipment use. Failure to follow instructions in the Operator's Manual may result in serious injury or death. The only warranty applicable to our equipment is the standard written warranty applicable to the particular product and sale and we make no other warranty, express or implied. Products and services listed may be trademarks, service marks or trade names of Terex Corporation and/or their subsidiaries in the USA and many other countries. Terex, Genie, Quality By Design, Xtra Capacity, Lift Power, Lift Guard, Lift Tools, Lift Connect and Tech Pro Link are registered trademarks of Terex Corporation or its subsidiaries.

05/23



Genie® SX™ -150

Specifications

Models	SX-150	
Measurements	US	Metric
Working height max. ⁽¹⁾	158 ft	48.33 m
Platform height max.	152 ft	46.33 m
Horizontal reach max.	80 ft	24.38 m
Below ground reach	2 ft	0.61 m
A Platform length	3 ft	0.91 m
B Platform width	8 ft	2.44 m
C Height - stowed	10 ft	3.05 m
D Length - stowed	53 ft 1 in	16.18 m
D Length - storage/transport (jib tucked under)	42 ft 8 in	13 m
E Width (axles retracted)	8 ft 2 in	2.49 m
E Width (axles extended)	16 ft 6 in	5.03 m
F Wheelbase (axles retracted)	16 ft 6 in	5.03 m
F Wheelbase (axles extended)	15 ft 6 in	4.72 m
G Ground clearance - center	1 ft 3 in	0.38 m
H Height under counterweight	4 ft 1 in	1.24 m

Productivity

Lift capacity max. - unrestricted	750 lb	340 kg
Number of Platform Occupants	2	
Platform rotation	160°	
Jib length	10 ft	3.05 m
Vertical jib rotation (up/down)	135°	
Horizontal jib rotation	60°	
Turntable rotation	360°	
Turntable tailswing (axles retracted)	3 ft 9 in	1.14 m
Turntable tailswing (axles extended)	3 ft 6 in	1.07 m
Drive speed - stowed	2.3 mph	3.7 km/h
Drive speed - raised	0.4 mph	0.65 km/h
Gradeability - stowed ⁽²⁾	35%	
Tilt sensor activation (front to back/side to side)	4.5°/3°	
Turning radius - inside/outside (axle retracted)	20 ft 7 in/28 ft 1 in	6.28 m/8.56 m
Turning radius - inside/outside (axle extended)	9 ft 11 in/24 ft 1 in	3.02 m/7.34 m
Tires	445D50/710	

Power

Power		Diesel
Hydraulic tank capacity	110 gal	416 L
Fuel tank capacity	50 gal	189 L

Weight⁽³⁾ and Floor Loading⁽⁴⁾

Weight	49,950 lb	22,657 kg
Tire contact pressure	130 psi	896 kPa
Occupied floor pressure, axles retracted/ extended	306 psf/ 159 psf	14,65 kPa/ 7,63 kPa

Sound and Vibration Levels

Sound Pressure level (ground workstation)	91 dBA
Sound Pressure level (platform workstation)	75 dBA
Vibrations	< 2.5 m/s ²

(1) The metric equivalent of working height adds 2 m to platform height. The imperial equivalent adds 6 ft to platform height.

(2) Gradeability applies to driving on slopes and may vary depending on options and machine configurations. See operator's manual for details regarding slope ratings.

(3) Weight refers to standard configuration and may vary depending on options and/or country standards.

(4) Floor loading information is approximate and may vary depending on options and machine configurations. It should be used only with adequate safety factors.

Range of motion SX-150

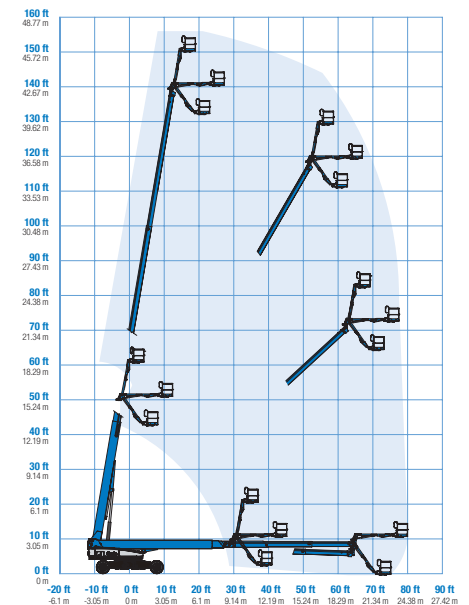

Jib range of motion SX-150

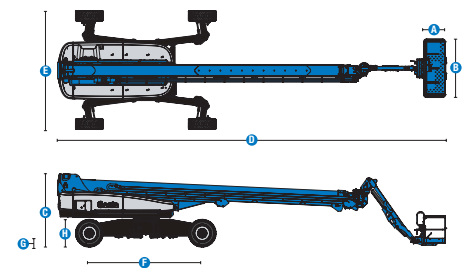
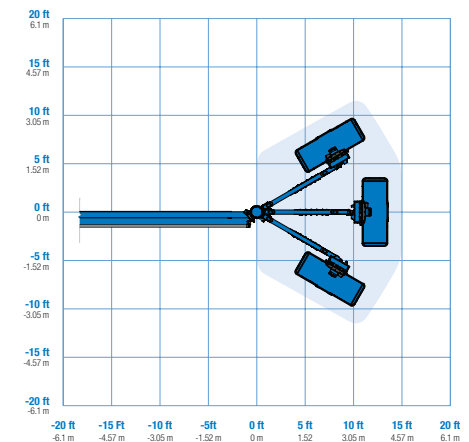

Genie® SX™ -150

SKU: Standard Model

- **SX150001AF0002:** SX-150, 12kW Welder Ready, 4WD
- SX-150, 4WD*

* Build to Order

Option availability	S	S+	BtO
Power			
74 hp, 55 kW, Deutz TD2.9L, Turbo Diesel, T4f	✓	✓	✓
Cold weather package			○
Diesel air intake pre-cleaner			○
Positive air shutdown system			○
Anti-restart engine protection	✓	✓	✓
Auto engine fault shutdown	✓	✓	✓
In cylinder glow plug (diesel only)	✓	✓	✓
Platform			
8ft/2.44m tri-entry platform with side swing gate	✓	✓	✓
Dual axis joystick steering	✓	✓	✓
Thumb rocker steering			○
Air line to platform			○
Control box covers		○	○
Lift Guard Full Mesh panels			○
Lift Guard Half Mesh panels			○
Light Package: drive and work lights		○	○
7.5kW Welder Ready			○
12kW Welder Ready			○
10 ft/3.05 m Rotating Jib	✓	✓	✓
4 Steering modes	✓	✓	✓
750lb/340kg lift capacity	✓	✓	✓
Drive enable system	✓	✓	✓
Horn	✓	✓	✓
Lift Guard Contact Alarm	✓	✓	✓
Lift Tools Work Tray	✓	✓	✓
Platform load sense system	✓	✓	✓
Proportional controls	✓	✓	✓
Self-leveling platform	✓	✓	✓
Slew ring cover ring guard	✓	✓	✓
Chassis			
Lift Connect Telematics	✓	✓	✓
Telematics-ready	✓	✓	✓
Lift Connect with Access Manager upgrade		○	○
Biodegradable hydraulic oil			○
Cold weather hydraulic oil			○
Fire resistant hydraulic oil			○
Rough terrain, foam-filled tires	✓	✓	✓
Hostile environment kit			○
2 speed wheel motors	✓	✓	✓
Alarm package: includes flashing beacon and travel alarm	✓	✓	✓
Chassis tilt lift and drive function cut-out	✓	✓	✓
Descent, tilt and motion alarm	✓	✓	✓
Dual battery system	✓	✓	✓
Hour meter	✓	✓	✓
Hydraulic oil cooler	✓	✓	✓
Tech Pro Link connector	✓	✓	✓
XChassis extendable axles	✓	✓	✓

- S Standard
- S+ Standard +
- BtO Build to Order
- ✓ Standard Features
- Options



Stability



750lb/340kg
Lift Capacity



Rotating Jib
10ft/3.05m



Genie Genuine Accessories⁽¹⁾

- Lift Tools Productivity Tools
- Lift Connect Telematics
- Tech Pro Link Handheld Device

(1) More accessories available from Genie Genuine Parts.

Product specifications are subject to change without notice or obligation. Photographs and/or drawings herein are for illustrative purposes only. Refer to the appropriate Operator's Manual for instructions on proper equipment use. Failure to follow instructions in the Operator's Manual may result in serious injury or death. The only warranty applicable to our equipment is the standard written warranty applicable to the particular product and sale and we make no other warranty, express or implied. Products and services listed may be trademarks, service marks or trade names of Terex Corporation and/or their subsidiaries in the USA and many other countries. Terex, Genie, Quality By Design, Xtra Capacity, Lift Power, Lift Guard, Lift Tools, Lift Connect and Tech Pro Link are registered trademarks of Terex Corporation or its subsidiaries.

Genie® SX™ -180

Specifications

Models	SX-180	
Measurements	US	Metric
Working height max. ⁽¹⁾	186 ft	56.86 m
Platform height max.	180 ft	54.86 m
Horizontal reach max.	80 ft	24.38 m
Below ground reach	2 ft	0.61 m
A Platform length	3 ft	0.91 m
B Platform width	8 ft	2.44 m
C Height - stowed	10 ft	3.05 m
D Length - stowed	53 ft 1 in	16.18 m
D Length - storage/transport (jib tucked under)	42 ft 8 in	13 m
E Width (axles retracted)	8 ft 2 in	2.49 m
E Width (axles extended)	16 ft 6 in	5.03 m
F Wheelbase (axles retracted)	16 ft 6 in	5.03 m
F Wheelbase (axles extended)	15 ft 6 in	4.72 m
G Ground clearance - center	1 ft 3 in	0.38 m
H Height under counterweight	4 ft 1 in	1.24 m

Productivity

Lift capacity max. - unrestricted	750 lb	340 kg
Number of Platform Occupants	2	
Platform rotation	160°	
Jib length	10 ft	3.05 m
Vertical jib rotation (up/down)	135°	
Horizontal jib rotation	60°	
Turntable rotation	360°	
Turntable tailswing (axles retracted)	3 ft 9 in	1.14 m
Turntable tailswing (axles extended)	3 ft 6 in	1.07 m
Drive speed - stowed	2.3 mph	3.7 km/h
Drive speed - raised	0.4 mph	0.65 km/h
Gradeability - stowed ⁽²⁾	35%	
Tilt sensor activation (front to back/side to side)	4.5°/3°	
Turning radius - inside/outside (axle retracted)	20 ft 7 in/28 ft 1 in	6.28 m/8.56 m
Turning radius - inside/outside (axle extended)	9 ft 11 in/24 ft 1 in	3.02 m/7.34 m
Tires	445D50/710	

Power

Power		Diesel
Hydraulic tank capacity	110 gal	416 L
Fuel tank capacity	50 gal	189.3 L

Weight⁽³⁾ and Floor Loading⁽⁴⁾

Weight	55,000 lb	24,948 kg
Tire contact pressure	130 psi	896 kPa
Occupied floor pressure, axles retracted/ extended	337 psf/175 psf	16.12 kPa/ 8.39 kPa

Sound and Vibration Levels

Sound Pressure level (ground workstation)	91 dBA
Sound Pressure level (platform workstation)	75 dBA
Vibrations	< 2.5 m/s ²

(1) The metric equivalent of working height adds 2m to platform height. The imperial equivalent adds 6ft to platform height.
 (2) Gradeability applies to driving on slopes and may vary depending on options and machine configurations. See operator's manual for details regarding slope ratings.
 (3) Weight refers to standard configuration and may vary depending on options and/or country standards.
 (4) Floor loading information is approximate and may vary depending on options and machine configurations. It should be used only with adequate safety factors.

Range of motion SX-180

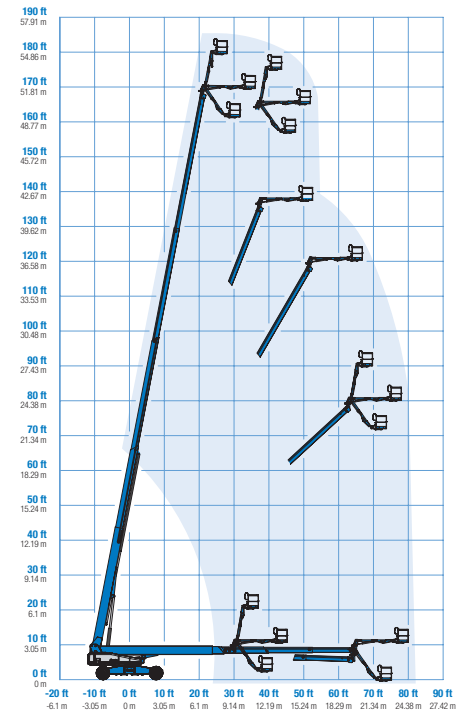

Jib range of motion SX-180

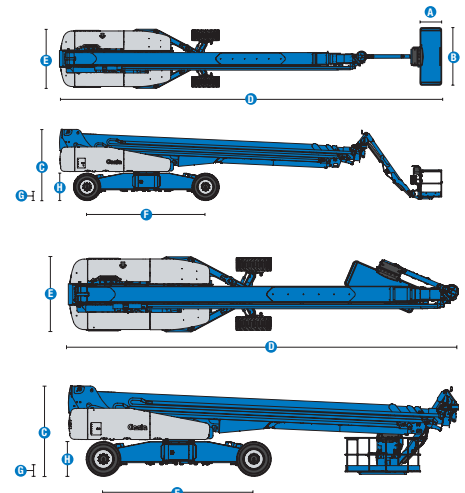
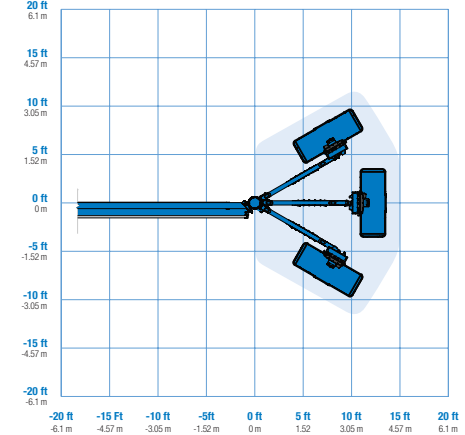

Genie® SX™ -180

SKU: Standard Model

- **SX180001AF0002:** SX-180, 12kW Welder Ready, 4WD
- SX-180, 4WD*

* Build to Order

Option availability	S	S+	BtO
Power			
74 hp, 55 kW, Deutz TD2.9L, Turbo Diesel, T4f	✓	✓	✓
Cold weather package			○
Diesel air intake pre-cleaner			○
Positive air shutdown system			○
Anti-restart engine protection	✓	✓	✓
Auto engine fault shutdown	✓	✓	✓
In cylinder glow plug (diesel only)	✓	✓	✓
Platform			
8ft/2.44m tri-entry platform with side swing gate	✓	✓	✓
Dual axis joystick steering	✓	✓	✓
Thumb rocker steering			○
Air line to platform			○
Control box covers		○	○
Lift Guard Full Mesh panels			○
Lift Guard Half Mesh panels			○
Light Package: drive and work lights		○	○
7.5kW Welder Ready			○
12kW Welder Ready			○
10 ft/3.05 m Rotating Jib	✓	✓	✓
4 Steering modes	✓	✓	✓
750lb/340kg lift capacity	✓	✓	✓
Drive enable system	✓	✓	✓
Horn	✓	✓	✓
Lift Guard Contact Alarm	✓	✓	✓
Lift Tools Work Tray	✓	✓	✓
Platform load sense system	✓	✓	✓
Proportional controls	✓	✓	✓
Self-leveling platform	✓	✓	✓
Slew ring cover ring guard	✓	✓	✓
Chassis			
Lift Connect Telematics	✓	✓	✓
Telematics-ready	✓	✓	✓
Lift Connect with Access Manager upgrade		○	○
Biodegradable hydraulic oil			○
Cold weather hydraulic oil			○
Fire resistant hydraulic oil			○
Rough terrain, foam-filled tires	✓	✓	✓
Hostile environment kit			○
2 speed wheel motors	✓	✓	✓
Alarm package: includes flashing beacon and travel alarm	✓	✓	✓
Chassis tilt lift and drive function cut-out	✓	✓	✓
Descent, tilt and motion alarm	✓	✓	✓
Dual battery system	✓	✓	✓
Hour meter	✓	✓	✓
Hydraulic oil cooler	✓	✓	✓
Tech Pro Link connector	✓	✓	✓
XChassis extendable axles	✓	✓	✓

- S Standard
- S+ Standard +
- BtO Build to Order
- ✓ Standard Features
- Options



Stability



750lb/340kg Lift Capacity



Rotating Jib 10ft/3.05m



Genie Genuine Accessories⁽¹⁾

- Lift Tools Productivity Tools
- Lift Connect Telematics
- Tech Pro Link Handheld Device

(1) More accessories available from Genie Genuine Parts.

Product specifications are subject to change without notice or obligation. Photographs and/or drawings herein are for illustrative purposes only. Refer to the appropriate Operator's Manual for instructions on proper equipment use. Failure to follow instructions in the Operator's Manual may result in serious injury or death. The only warranty applicable to our equipment is the standard written warranty applicable to the particular product and sale and we make no other warranty, express or implied. Products and services listed may be trademarks, service marks or trade names of Terex Corporation and/or their subsidiaries in the USA and many other countries. Terex, Genie, Quality By Design, Xtra Capacity, Lift Power, Lift Guard, Lift Tools, Lift Connect and Tech Pro Link are registered trademarks of Terex Corporation or its subsidiaries.

GENIE® TZ™ BOOM LIFTS

Trailer-mounted TZ™ boom lifts combine the up-and-over access of an articulating boom with the convenience of a built-in trailer. Most suitable for contractors, they can be easily towed behind a pickup truck or SUV. Their compact dimensions and low ground pressure make them ideal for work on sensitive floors such as lawns, gym floors and in historical or worship buildings.

EASY
TOWING

INTUITIVE
CONTROLS

LOW
GROUND
PRESSURE

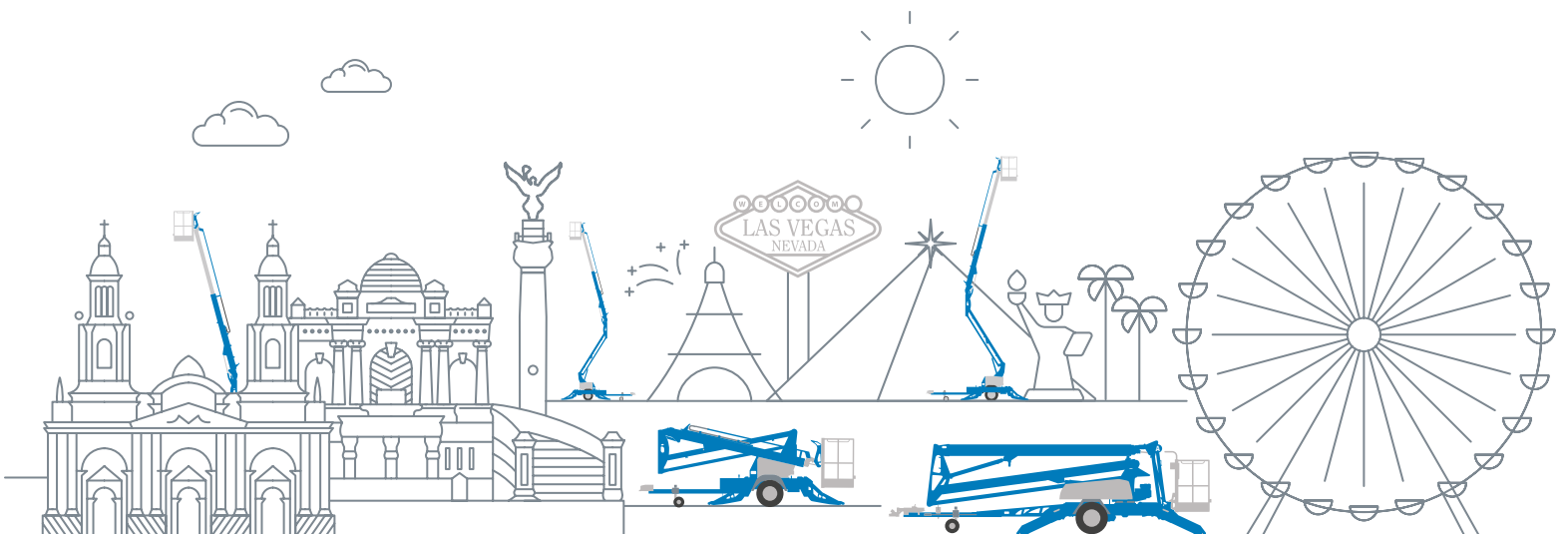



Specifications

Trailer-Mounted TZ™ Boom Lifts

MODEL	MAX. PLATFORM HEIGHT	HORIZONTAL REACH	UP & OVER CLEARANCE	MAX. LIFT CAPACITY**	WIDTH*	TRANSPORT LENGTH*	WEIGHT*
Trailer-Mounted TZ™ Boom Lifts							
TZ™-34/20	34 ft	18 ft 4 in	16 ft 1 in	500 lb	4 ft 9.1 in	18 ft 0.5 in	3,155 lb
TZ-50	49 ft 6 in	29 ft 2 in	22 ft	500 lb	5 ft 6 in	23 ft 6 in	4,400 lb

* With standard configuration. Will vary depending on options and/or country standards.

** Lift capacity depends on options and country standards

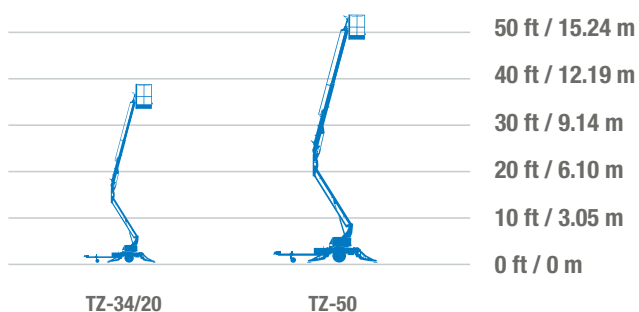

Genie® TZ™ -34/20 & TZ-50

Specifications

Models	TZ-34/20		TZ-50	
Measurements	US	METRIC	US	METRIC
Working height max. - ⁽¹⁾	40 ft	12.19 m	55 ft 6 in	16.92 m
Platform height	34 ft	10.36 m	49 ft 6 in	15.09 m
Entry height- extended	6.4 in	0.16 m	1 ft 8 in	0.51 m
Horizontal reach	18 ft 4 in	5.59 m	29 ft 2 in	8.89 m
Clear out reach	13 ft 5 in	4.09 m	23 ft 1 in	7.04 m
Up-and-over clearance	16 ft 1 in	4.90 m	22 ft	6.71 m
A Platform length	2 ft 2.8 in	0.68 m	2 ft 2.8 in	0.68 m
B Platform width	3 ft 8 in	1.12 m	3 ft 8 in	1.12 m
C Height - stowed	6 ft 4.5 in	1.94 m	6 ft 10 in	2.08 m
D Length- stowed	18 ft 0.5 in	5.50 m	23 ft 6 in	7.16 m
E Width- stowed	4 ft 9.1 in	1.45 m	5 ft 6 in	1.68 m
F Ground clearance	9.5 in	0.24 m	10 in	0.25 m
G Length-outrigger footprint	10 ft 8.4 in	3.26 m	14 ft 4 in	4.37 m
H Width-outrigger footprint	11 ft 9.4 in	3.59 m	14 ft 4 in	4.37 m

Productivity

Lift capacity (ANSI, CSA) - standard	500 lb	227 kg	500 lb	227 kg
Lift capacity (ANSI, CSA) - rotating platform	460 lb	209 lb	500 lb	227 kg
Lift capacity (CE/AUS) - standard	440 lb	200 kg	440 lb	200 kg
Lift capacity (CE/AUS) - rotating platform	400 lb	181 kg	440 lb	200 kg
Platform rotation - mechanical	90°		-	
Platform rotation - hydraulic	-		160°	
Turntable rotation	359°	359°	359°	359°
Outrigger leveling capability	11°		11°	
Towing speed rate	60 mph	97 km/h	60 mph	97 km/h
Tongue weight - ANSI, CSA	315 lb	143 kg	400 lb	181 kg
Tongue weight - CE	163 lb	74 kg	220 lb	100 kg
Tire size - ANSI, CSA	ST 205/75 R15		ST 225/75 R15	
Tire size - CE	185R-14C		215 R14C	

Power

Power source- standard	24V (4x6V 225Ah)		24V (4x6V 225Ah)	
Hydraulic tank capacity	2.65 gal	10L	4.75 gal	18L
Hydraulic system capacity	4.5 gal	17L	8.0 gal	30L

Weight⁽³⁾

Weight- ANSI, CSA, Australia	3,155 lb	1,431 kg	4,400 lb	1,996 kg
Weight- CE	3,170 lb	1,438 kg	4,475 lb	2,030 kg

Sound and Vibration Levels

Sound Pressure level (ground workstation)	< 70 dBA	< 70 dBA
Sound Pressure level (platform workstation)	< 70 dBA	< 70 dBA
Vibrations	< 2.5 m/s ²	< 2.5 m/s ²

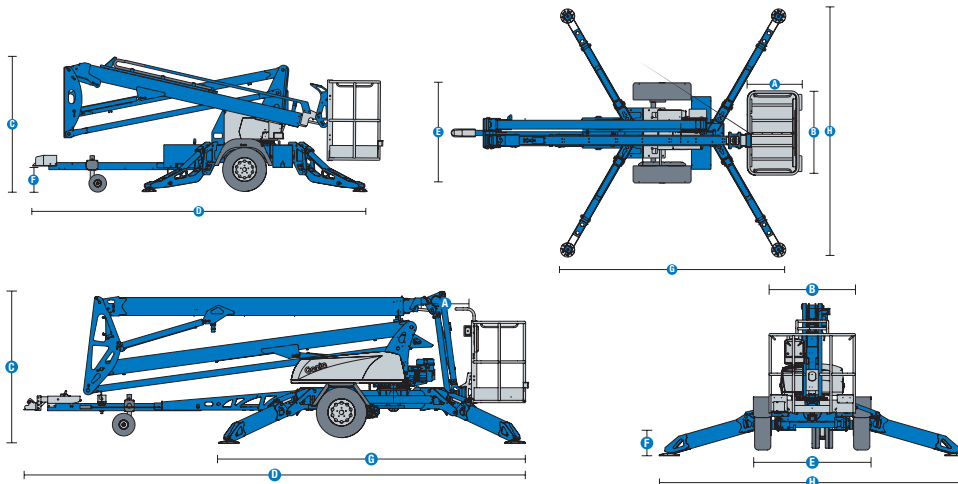

Range of motion TZ-34/20

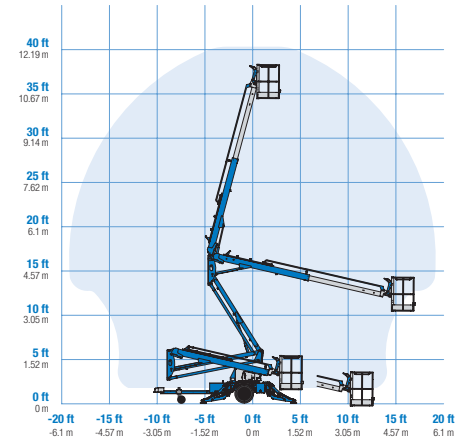

Range of motion TZ-50

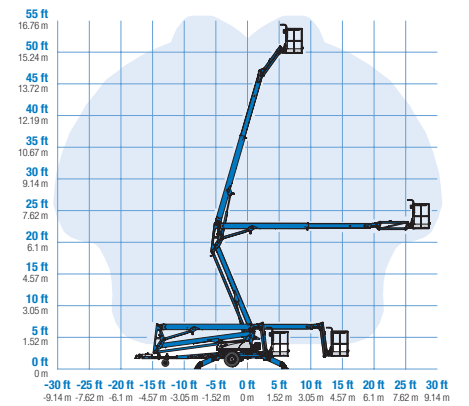

Genie® TZ™ -34/20 & TZ-50

SKU: Standard Model

- **TZ340001AD0001:** TZ-34 DC
- **TZ500001AD0002:** TZ-50 DC
- **TZ500001AD0001:** TZ-50 DC, Hybrid

* Build to Order

Option availability	S	S+	BtO	
Power	Standard battery	✓	✓	✓
	High capacity battery		○	○
	Bi-Energy, Honda Gas	✓	✓	✓
	Battery charge indicator (BCI)		○	○
	24V DC Power	✓	✓	✓
Platform	Horn		○	○
	AC wiring to platform	✓	✓	✓
	Aluminum 26.8in x 44in platform	✓	✓	✓
	Hydraulic platform rotation 160 degrees (TZ-50)			○
	Manual platform rotation 90 degrees (TZ-34)			○
	Tilt alarm sensor	✓	✓	✓
Variable speed control system	✓	✓	✓	
Chassis	Lift Connect Telematics		○	○
	Lift Connect with Access Manager upgrade		○	○
	2in Ball Bulldog coupler		○	○
	Combination hitch with choice of coupler	✓	✓	✓
	2in Ball Leverlock coupler	✓	✓	✓
	2 5/16in Ball Leverlock coupler		○	○
	Clevis coupler		○	○
	I.D. pintle ring coupler 2 1/2in		○	○
	Drive and set option			○
	Flashing beacon		○	○
	Non-marking outrigger foot pads		○	○
	Spare tire		○	○
	10in solid plastic wheel	✓	✓	✓
	355 degree non-continuous rotation	✓	✓	✓
	Automatic 11 degree leveling system	✓	✓	✓
	Auxiliary platform descent	✓	✓	✓
	Highway safety chains with snap lock	✓	✓	✓
	Hour meter	✓	✓	✓
	Hydraulic outriggers	✓	✓	✓
	Hydraulic surge brakes	✓	✓	✓
Illuminated outrigger indicators	✓	✓	✓	
LED brake light	✓	✓	✓	
Mechanical parking brake	✓	✓	✓	
Outrigger interlocks	✓	✓	✓	

Drive and set option available for TZ-50 only

- S Standard
- S+ Standard +
- BtO Build to Order
- ✓ Standard Features
- Options



Truck Towable



Quick Setup



Low Floor Loading

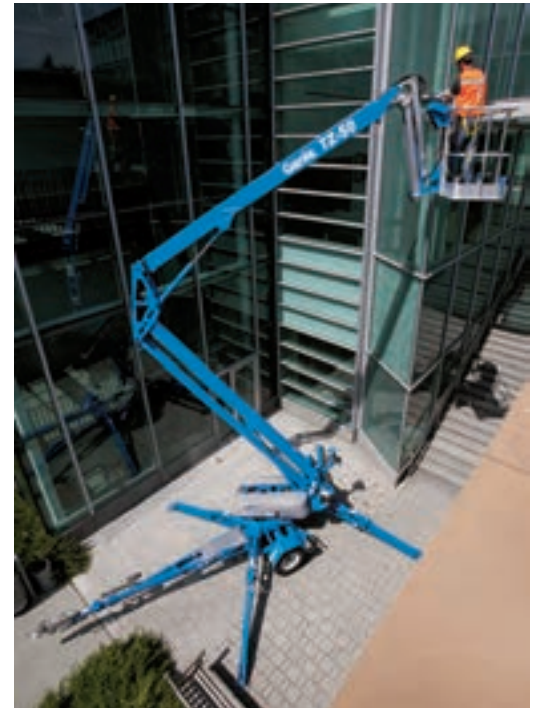

Genie Genuine Accessories⁽¹⁾

- Ball coupler 2 5/16 in
- Clevis coupler
- Dual 10in air-filled tires (TZ-34/20 only)
- I.D. pintle ring coupler 2 1/2 in

(1) More accessories available from Genie Genuine Parts.

Product specifications are subject to change without notice or obligation. Photographs and/or drawings herein are for illustrative purposes only. Refer to the appropriate Operator's Manual for instructions on proper equipment use. Failure to follow instructions in the Operator's Manual may result in serious injury or death. The only warranty applicable to our equipment is the standard written warranty applicable to the particular product and sale and we make no other warranty, express or implied. Products and services listed may be trademarks, service marks or trade names of Terex Corporation and/or their subsidiaries in the USA and many other countries. Terex, Genie, Quality By Design, Xtra Capacity, Lift Power, Lift Guard, Lift Tools, Lift Connect and Tech Pro Link are registered trademarks of Terex Corporation or its subsidiaries.

GENIE® GTH™ TELEHANDLERS

Genie® GTH™ telehandlers provide durability and versatility for pick, carry, place and lift tasks on a wide range of demanding jobsites, from power plants and energy sites, to residential and commercial construction and jobsite cleanup.

Genie telehandlers have been redesigned from the ground up with high-quality and rigorously tested components for enhanced performance and a reduced cost of ownership. A growing selection of attachments further boosts productivity and versatility including multi-purpose buckets, auger tools and carriage options.

RELIABLE
COMPONENTS

OPTIMIZED
LOAD CHART

EASY
OPERATION
AND SERVICE

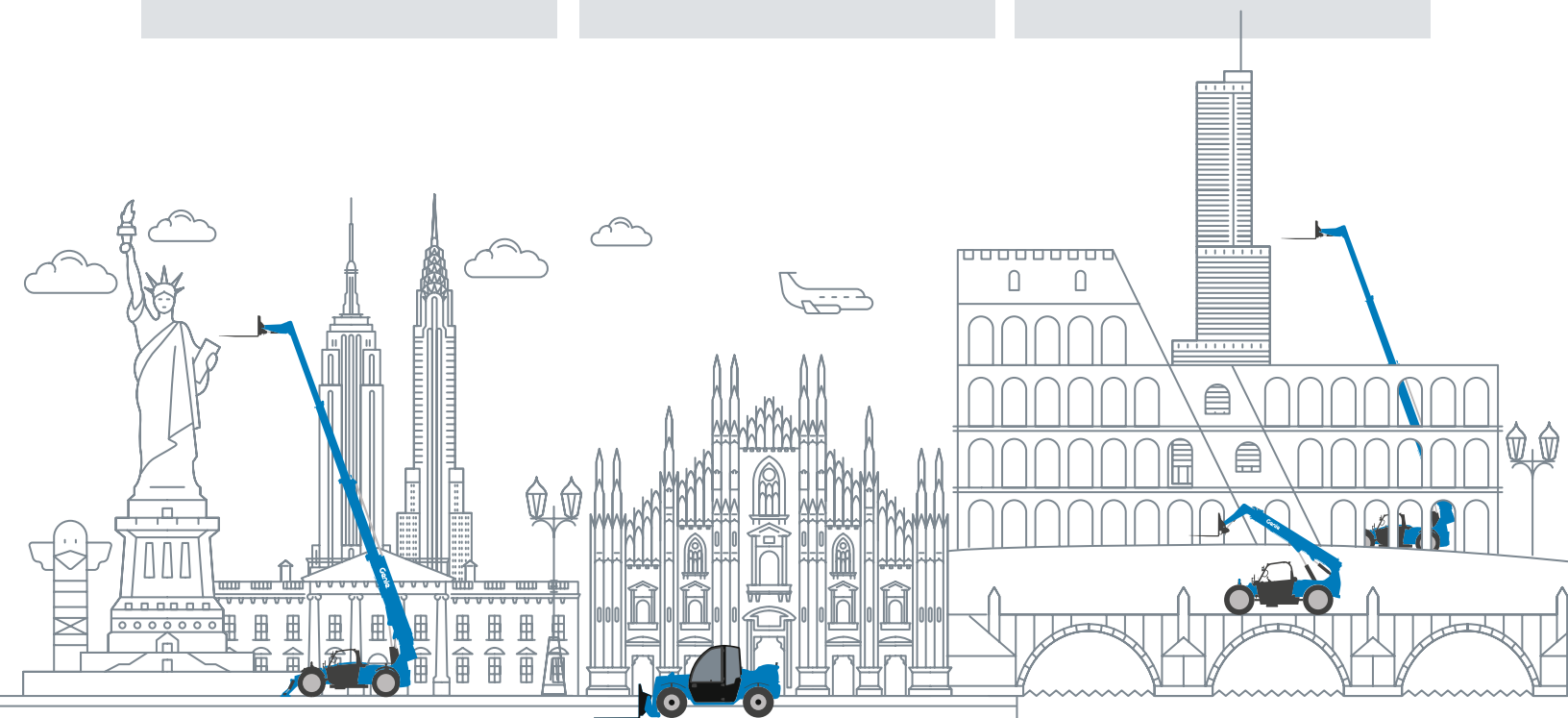



Genie GTH-1056

Specifications

GTH™ Telehandlers

MODEL	MAX. LIFT HEIGHT	MAX. FORWARD REACH	MAX. LIFT CAPACITY	WIDTH*	TRANSPORT LENGTH*	WEIGHT*
Genie® Telehandlers						
GTH™-5519	18 ft 10 in	11 ft 3 in	5,500 lb	5 ft 11 in	12 ft 3 in**	10,360 lb
GTH-636	36 ft	21 ft 11 in	6,000 lb	7 ft 11 in	17 ft 10 in**	17,600 lb
GTH-844	43 ft 10 in	28 ft 2 in	8,000 lb	8 ft 1.5 in	20 ft 3 in**	22,600 lb
GTH-1044	44 ft 7 in	30 ft 7 in	10,000 lb	8 ft 6 in	22 ft 2 in**	26,700 lb
GTH-1056	56 ft 7 in	42 ft	10,000 lb	8 ft 6 in	22 ft 6 in**	31,900 lb
GTH-1244	44 ft 7 in	30 ft 7 in	12,000 lb	8 ft 6 in	22 ft 2 in**	28,900 lb
GTH-1256	56 ft 3 in	42 ft	12,000 lb	8 ft 6 in	22 ft 8 in**	34,500 lb

* With standard configuration. Will vary depending on options and/or country standards.

** Without forks.

LOAD CHARTS

GTH-5519

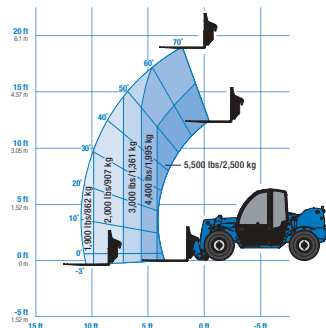

GTH-636

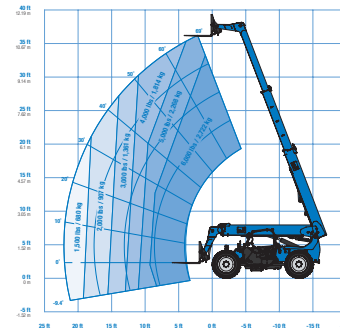

GTH-844

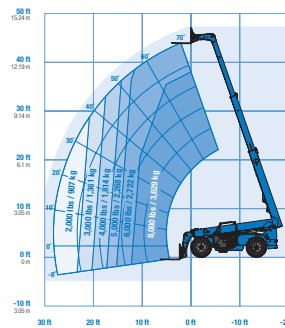

GTH-1044

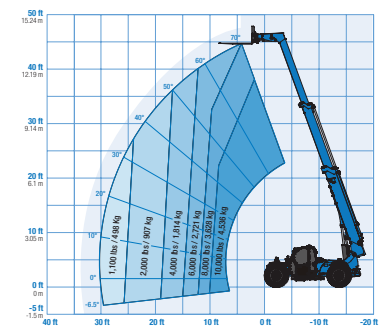

GTH-1056 (stabilizers down)

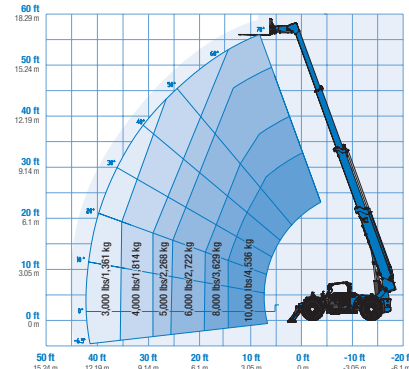

GTH-1244

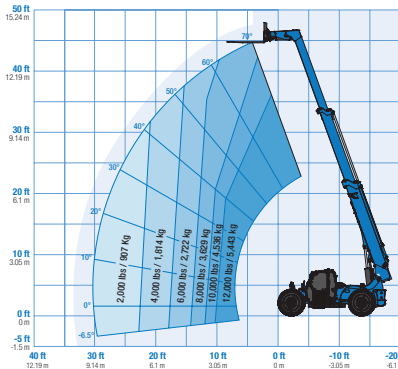

GTH-1256 (stabilizers down)

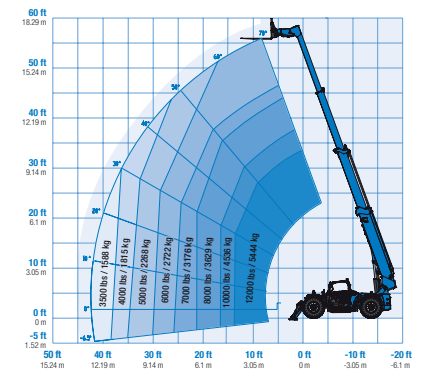

Genie® GTH™ -5519

Specifications

Models	GTH-5519	
Measurements	US	METRIC
Maximum lift height	18 ft 10 in	5.74 m
Maximum forward reach	11 ft 3 in	3.43 m
Reach at maximum height	1 ft 10 in	0.56 m
A Height, stowed	6 ft 6 in	1.98 m
B Length, stowed (without forks)	12 ft 3 in	3.73 m
Width	5 ft 11 in	1.80 m
C Wheelbase	7 ft 6 in	2.29 m
D Ground clearance, center	1 ft 2 in	0.36 m
E Ground clearance, axle	10 in	0.25 m
Fork cross section	1.6×4 in	40×100 mm

Productivity

Maximum lift capacity	5,500 lb	2,495 kg
Lift capacity at maximum height	4,400 lb	1,996 kg
Lift capacity at maximum reach	1,900 lb	862 kg
Drive speed	15 mph	24 km/h
Draw bar pull	7,716 lb	3,500 kg
Turning radius, outside (4WS)	11 ft	3.35 m
Auxiliary hydraulic flow	17 gpm	64 lpm
Auxiliary hydraulic pressure	3,918 psi	270 bar
Tires, standard size	12×16.5 in, 10 ply	0.30×0.42 m, 10 ply

Power

Power source	Deutz TCD 2.9	Deutz TCD 2.9
Electrical system voltage	12V	
Alternator	95 amp	
Battery	720 CCA 0°F (-18°C)	
Hydraulic tank capacity	18.5 gal	70L
Hydraulic system capacity (w/tank)	31.7 gal	120 L
Fuel tank capacity	15.8 gal	59.8 L

Weight

Weight*	10,360 lb	4,700 kg
---------	-----------	----------

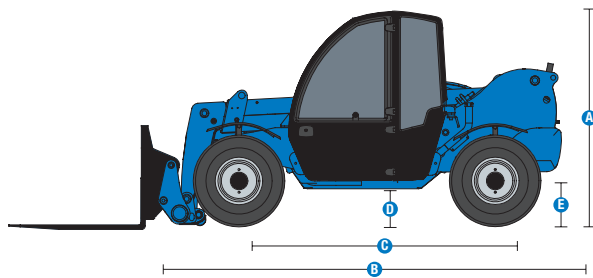

Range of motion GTH-5519

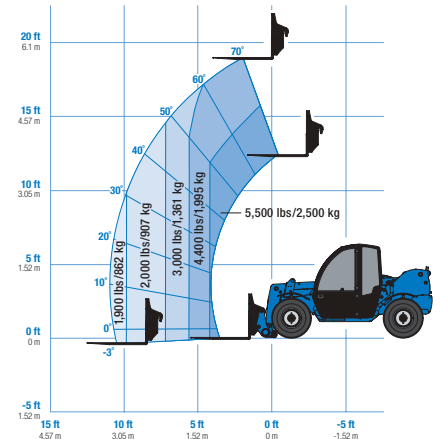

(1) Weight will vary depending on options and/or country standards.
 (2) Load ratings vary depending on attachment.

Genie® GTH™ -5519

SKU: Standard Model

- **GTH55191AF0112:** GTH-5519, 74 hp, Open cab
- **GTH55191AF0152:** GTH-5519, 74 hp, Closed cab w/ heater
- **GTH55191AF0151:** GTH-5519, 74 hp, Closed cab w/ AC and heater

* Build to Order

Option availability		S	S+	BtO
Cab	Cab ROPS/FOPS canopy*	✓	✓	✓
	Closed cab: Heater, defrost, wipers, washer, split door*	✓	✓	✓
	Closed cab: AC, heater, defrost, wipers, washer, split door*	✓	✓	✓
	Front and top glass		○	○
	Lift Guard White Noise Alarm		○	○
	Rear Proximity Alarm		○	○
	Fire extinguisher		○	○
	3in/7.6cm high visibility red retractable seat belt	✓	✓	✓
	Adjustable suspended seat	✓	✓	✓
	Backup alarm	✓	✓	✓
	Full gauge cluster with engine diagnostics	✓	✓	✓
	Fully proportional boom and auxiliary hydraulic controls	✓	✓	✓
	Machine level indicator	✓	✓	✓
	Mirrors - LH canopy mounted and RH chassis mounted	✓	✓	✓
	Multi-function joystick controller	✓	✓	✓
	Power steering	✓	✓	✓
RH steel mesh screen	✓	✓	✓	
Tilt steering wheel	✓	✓	✓	
Top glass	✓	✓	✓	
Chassis	74 hp, Deutz TCD 2.9, T4f, Side-mounted engine	✓	✓	✓
	Telematics-ready	✓	✓	✓
	Lift Connect Telematics		○	○
	Lift Connect with Access Manager upgrade		○	○
	Brick guard		○	○
	Cold weather package			○
	Electric oil pan heater			○
	Fenders set of four	✓	✓	✓
	Lojack stolen vehicle recovery system			○
	Positive air shutdown system			○
	Flashing Beacon		○	○
	Work lights: High output LED cab, boom, rear		○	○
	Road and work lights: High output LED front, cab, boom, rear		○	○
	Air-filled rough terrain tires	✓	✓	✓
	Air-filled turf tires		○	○
	Foam-filled rough terrain tires		○	○
Non-marking, air-filled tires		○	○	
Non-marking, foam-filled tires		○	○	
Solid rough terrain tires		○	○	
3-mode steering (2-wheel, 4-wheel and crab) with limited slip front differential	✓	✓	✓	
Cold start intake glow plugs	✓	✓	✓	
Full time 4WD with front limited slip differential (LSD)	✓	✓	✓	
Internal multiple wet disc brakes	✓	✓	✓	
Spring applied, hydraulic release parking brake	✓	✓	✓	
Variable speed hydrostatic drive	✓	✓	✓	
Boom	Genie manual Quick-Attach (QA) system	✓	✓	✓
	Genie hydraulic Quick-Attach (QA) system			○
	Auxiliary hydraulic circuit (18.5 GPM)	✓	✓	✓
	Boom angle indicator	✓	✓	✓
	Lifting shackle at boom tip	✓	✓	✓
	Self-leveling fork frame	✓	✓	✓

*Choose from either Open cab or Closed cab/ Heater only or AC and Heater

- S Standard
- S+ Standard +
- BtO Build to Order
- ✓ Standard Features
- Options



Compact Footprint



Lift Shackle



Material Handling Attachments



GTH Attachments

- Universal skid steer adapter (GTH-5519)
- QA Bucket .5cu.yd/0.38cu.m, 66in/1.67m (GTH-5519)
- QA Bucket 1cu.yd/0.76cu.m, 72in/1.82m (GTH-636, GTH-844)
- QA Bucket 1.5cu.yd/1.15cu.m, 96in/2.44m
- QA Carriage 48in/1.2m, 60in/1.5m, 72in/1.8m
- QA Fork positioner carriage 48in/1.2m
- QA Side shift carriage 48in/1.2m
- QA Side tilt rotating carr. 48in/1.2m, 60in/1.5m, 72in/1.8m
- QA Swing carriage 72in/1.8m
- QA Truss boom 8ft/2.44m Adjustable
- Cubing tines 48in (2x2x48in)/(.05x.05x1.2m) x 6
- Lumber forks 60in (1.75x7x60in)/(.04x.18x1.5m) x 2
- Pallet forks 48in (2x4x48in)/(.05x.1x1.2m) set of 2
- Pallet forks 60in (2x4x60in)/(.05x.1x1.5m) set of 2
- Pallet forks 72in (2x4x72in)/(.05x.1x1.8m) set of 2
- Pallet forks 96in (2x4x96in)/(.05x.1x2.4m) set of 2

Product specifications are subject to change without notice or obligation. Photographs and/or drawings herein are for illustrative purposes only. Refer to the appropriate Operator's Manual for instructions on proper equipment use. Failure to follow instructions in the Operator's Manual may result in serious injury or death. The only warranty applicable to our equipment is the standard written warranty applicable to the particular product and sale and we make no other warranty, express or implied. Products and services listed may be trademarks, service marks or trade names of Terex Corporation and/or their subsidiaries in the USA and many other countries. Terex, Genie, Quality By Design, Xtra Capacity, Lift Power, Lift Guard, Lift Tools, Lift Connect and Tech Pro Link are registered trademarks of Terex Corporation or its subsidiaries.

Genie® GTH™ -636

Specifications

Models	GTH-636	
Measurements	US	METRIC
Maximum lift height	36 ft	10.97 m
Maximum forward reach	21 ft 11 in	6.68 m
Reach at maximum height	1 ft 10 in	0.56 m
A Height, stowed	7 ft 10 in	2.39 m
B Length, stowed (without forks)	17 ft 10 in	5.44 m
Width	7 ft 11 in	2.41 m
C Wheelbase	10 ft 11 in	3.33 m
D Ground clearance, center	1 ft 3 in	0.38 m
E Ground clearance, axle	1 ft 5 in	0.43 m
Fork cross section	2×4 in	51×101 mm

Productivity

Maximum lift capacity	6,000 lb	2,722 kg
Lift capacity at maximum height	5,000 lb	2,268 kg
Lift capacity at maximum reach	1,500 lb	680 kg
Drive speed	18 mph	29 km/h
Boom up/down		10/8 sec
Boom extend/retract		11/9 sec
Draw bar pull	15,100 lb	6,849 kg
Frame leveling (side to side)		10°
Turning radius, outside (4WS)	13 ft 4 in	4.06 m
Auxiliary hydraulic flow	2-15 gpm	7.57-56.8 lpm
Auxiliary hydraulic pressure	3,000 psi	206.8 bar
Tires, standard size	13×28 in, 12 ply	0.33×0.71 m, 12 ply

Power

Power source	Deutz 2.9 TCD	
Electrical system voltage	12V	
Alternator	95 amp	
Battery	1000 CCA 0°F (-18°C)	
Hydraulic tank capacity	34.0 gal	128.7L
Hydraulic system capacity (w/tank)	46.5 gal	176.0L
Fuel tank capacity	27.0 gal	102.2L

Weight

Weight*	17,600 lb	7,983 kg
---------	-----------	----------

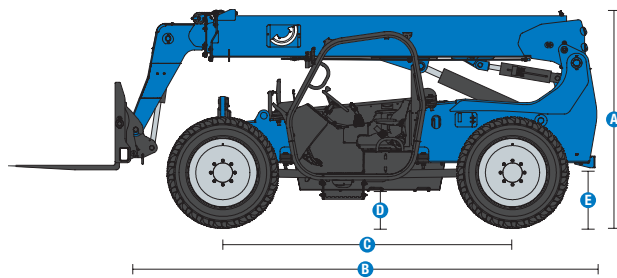

Range of motion GTH-636

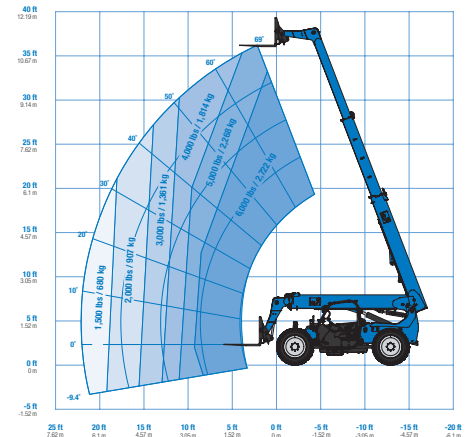

(1) Weight will vary depending on options and/or country standards.
 (2) Load ratings vary depending on attachment.

Genie® GTH™ -636

SKU: Standard Model

- **GTH63601AF0085:** GTH-636, 74 hp, Open cab
- **GTH63601AF0086:** GTH-636, 74 hp, Open cab, Work lights, Flashing beacons

SKU: Standard Model

- **GTH63601AF0088:** GTH-636, 74 hp, Closed cab w/ heater
 - **GTH63601AF0090:** GTH-636, 74 hp, Closed cab w/ AC and heater
- * Build to Order

Option availability		S	S+	BtO
Cab	Open cab ROPS/FOPS canopy*	✓	✓	✓
	Closed cab: Heater, defrost, wipers, washer, split door*	✓	✓	✓
	Closed cab: AC, heater, defrost, wipers, washer, split door*	✓	✓	✓
	Front and top glass		○	○
	Lift Guard White Noise Alarm		○	○
	Rear Proximity Alarm		○	○
	Rear proximity alarm with back-up camera and display		○	○
	Fire extinguisher		○	○
	3in/7.6cm high visibility red retractable seat belt	✓	✓	✓
	Adjustable suspended seat	✓	✓	✓
	Backup alarm	✓	✓	✓
	Full gauge cluster with engine diagnostics	✓	✓	✓
	Fully proportional hydraulic boom controls	✓	✓	✓
	Machine level indicator	✓	✓	✓
	Mirrors - LH canopy mounted and RH chassis mounted	✓	✓	✓
	Multi-function joystick controller	✓	✓	✓
	Power steering	✓	✓	✓
	RH steel mesh screen	✓	✓	✓
	Tilt steering wheel	✓	✓	✓
	Chassis	74 hp, Deutz TCD 2.9, T4f, Side-mounted engine	✓	✓
Powershift transmission (PS) 3-speed 74 hp		✓	✓	✓
Telematics-ready		✓	✓	✓
Lift Connect Telematics			○	○
Lift Connect with Access Manager upgrade			○	○
Cold weather package				○
Extreme cold weather package				○
Fenders set of four			○	○
Lojack stolen vehicle recovery system				○
Positive air shutdown system				○
Flashing beacon			○	○
Work lights: High output LED cab, boom, rear			○	○
Road and work lights: High output LED front, cab, boom, rear			○	○
Air-filled Enduro A/T tires		✓	✓	✓
Foam-filled Enduro A/T tires			○	○
Non-marking, foam-filled tires			○	○
Solid rough terrain tires			○	○
Lockable battery disconnect		○	○	
3-mode power steering (2-wheel, 4-wheel coordinated and crab)	✓	✓	✓	
Frame leveling +/- 10 degrees	✓	✓	✓	
Full time 4WD with front limited slip differential (LSD)	✓	✓	✓	
Internal multiple wet disc brakes	✓	✓	✓	
Spring applied, hydraulic release parking brake	✓	✓	✓	
Boom	Genie manual Quick-Attach (QA) system	✓	✓	✓
	Auxiliary hydraulic circuit (15 GPM)	✓	✓	✓
	Boom angle indicator	✓	✓	✓
	Lifting shackle at boom tip	✓	✓	✓
	Self-leveling fork frame	✓	✓	✓

*Choose from either Open cab or Closed cab/ Heater only or AC and Heater

- S Standard
- S+ Standard +
- BtO Build to Order
- ✓ Standard Features
- Options



Side Mounted Engine



Lift Shackle



Long Life Tires



GTH Attachments

- Universal skid steer adapter (GTH-5519)
- QA Bucket .5cu.yd/0.38cu.m, 66in/1.67m (GTH-5519)
- QA Bucket 1cu.yd/0.76cu.m, 72in/1.82m (GTH-636, GTH-844)
- QA Bucket 1.5cu.yd/1.15cu.m, 96in/2.44m
- QA Carriage 48in/1.2m, 60in/1.5m, 72in/1.8m
- QA Fork positioner carriage 48in/1.2m
- QA Side shift carriage 48in/1.2m
- QA Side tilt rotating carr. 48in/1.2m, 60in/1.5m, 72in/1.8m
- QA Swing carriage 72in/1.8m
- QA Truss boom 8ft/2.44m Adjustable
- Cubing tines 48in (2x2x48in)/(.05x.05x1.2m) x 6
- Lumber forks 60in (1.75x7x60in)/(.04x.18x1.5m) x 2
- Pallet forks 48in (2x4x48in)/(.05x.1x1.2m) set of 2
- Pallet forks 60in (2x4x60in)/(.05x.1x1.5m) set of 2
- Pallet forks 72in (2x4x72in)/(.05x.1x1.8m) set of 2
- Pallet forks 96in (2x4x96in)/(.05x.1x2.4m) set of 2

Product specifications are subject to change without notice or obligation. Photographs and/or drawings herein are for illustrative purposes only. Refer to the appropriate Operator's Manual for instructions on proper equipment use. Failure to follow instructions in the Operator's Manual may result in serious injury or death. The only warranty applicable to our equipment is the standard written warranty applicable to the particular product and sale and we make no other warranty, express or implied. Products and services listed may be trademarks, service marks or trade names of Terex Corporation and/or their subsidiaries in the USA and many other countries. Terex, Genie, Quality By Design, Xtra Capacity, Lift Power, Lift Guard, Lift Tools, Lift Connect and Tech Pro Link are registered trademarks of Terex Corporation or its subsidiaries.

Genie® GTH™ -844

Specifications

Models	GTH-844	
Measurements	US	METRIC
Maximum lift height	43 ft 10 in	13.36 m
Maximum forward reach	28 ft 2 in	8.59 m
Reach at maximum height	2 ft 1 in	0.64 m
A Height, stowed	7 ft 10 in	2.39 m
B Length, stowed (without forks)	20 ft 3 in	6.17 m
Width	8 ft 1.5 in	2.48 m
C Wheelbase	11 ft 4 in	3.45 m
D Ground clearance, center	1 ft 3 in	0.38 m
E Ground clearance, axle	1 ft 5 in	0.43 m
Fork cross section	2×4 in	51×101 mm

Productivity

Maximum lift capacity	8,000 lb	3,629 kg
Lift capacity at maximum height	6,000 lb	2,722 kg
Lift capacity at maximum reach	2,000 lb	907 kg
Drive speed	15 mph	24 km/h
Boom up/down		13/10 sec
Boom extend/retract		14/9 sec
Draw bar pull	21,000 lb	9,525 kg
Frame leveling (side to side)		10°
Turning radius, outside (4WS)	13 ft 9 in	4.19 m
Auxiliary hydraulic flow	2-15 gpm	7.57-56.8 lpm
Auxiliary hydraulic pressure	3,000 psi	206.8 bar
Tires, standard size	13×28 in, 12 ply	0.33×0.71 m, 12 ply

Power

Power source	Deutz TCD 3.6	
Electrical system voltage	12V	
Alternator	95 amp	
Battery	1000 CCA 0°F (-18°C)	
Hydraulic tank capacity	40 gal	151.4 L
Hydraulic system capacity (w/tank)	55 gal	208.2 L
Fuel tank capacity	32 gal	121 L

Weight

Weight*	22,600 lb	10,251 kg
---------	-----------	-----------

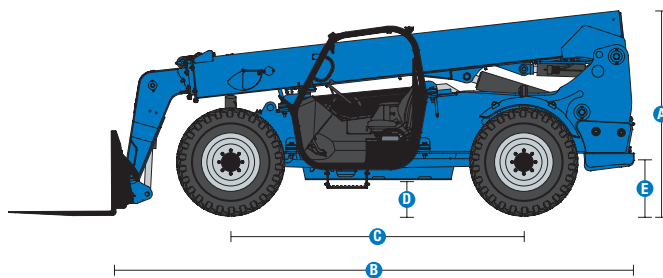

Range of motion GTH-844

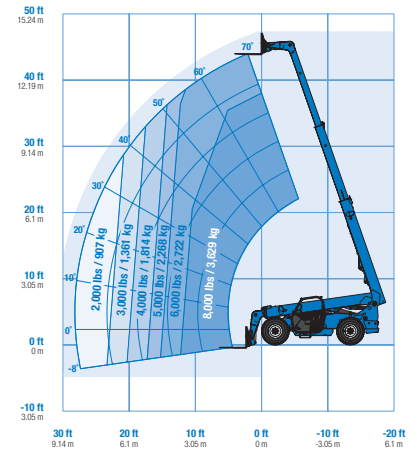

(1) Weight will vary depending on options and/or country standards.
 (2) Load ratings vary depending on attachment.

Genie® GTH™ -844

SKU: Standard Model

- **GTH84401AF0110:** GTH-844, 74 hp, Open cab
- **GTH84401AF0111:** GTH-844, 74 hp, Open Cab, Work lights, Flashing beacons

* Build to Order

SKU: Standard Model

- **GTH84401AF0113:** GTH-844, 74 hp, Closed cab w/ heater
- **GTH84401AF0112:** GTH-844, 74 hp, Closed cab w/ AC and heater

Option availability		S	S+	BtO	
Cab	Open cab ROPS/FOPS canopy*	✓	✓	✓	
	Closed cab: Heater, defrost, wipers, washer, split door*	✓	✓	✓	
	Closed cab: AC, heater, defrost, wipers, washer, split door*	✓	✓	✓	
	Front and top glass		○	○	
	Lift Guard White Noise Alarm		○	○	
	Rear Proximity Alarm		○	○	
	Rear proximity alarm with back-up camera and display		○	○	
	Fire extinguisher		○	○	
	3in/7.6cm high visibility red retractable seat belt	✓	✓	✓	
	Adjustable suspended seat	✓	✓	✓	
	Backup alarm	✓	✓	✓	
	Full gauge cluster with engine diagnostics	✓	✓	✓	
	Fully proportional hydraulic boom controls	✓	✓	✓	
	Machine level indicator	✓	✓	✓	
	Mirrors - LH canopy mounted and RH chassis mounted	✓	✓	✓	
	Multi-function joystick controller	✓	✓	✓	
	Power steering	✓	✓	✓	
	RH steel mesh screen	✓	✓	✓	
	Tilt steering wheel	✓	✓	✓	
	Chassis	74 hp, Deutz TCD 3.6, T4f, Side-mounted engine	✓	✓	✓
		Powershift transmission (PS) 3-speed 74 hp	✓	✓	✓
Telematics-ready		✓	✓	✓	
Lift Connect Telematics			○	○	
Lift Connect with Access Manager upgrade			○	○	
Cold weather package				○	
Extreme cold weather package				○	
Fenders set of four			○	○	
Lojack stolen vehicle recovery system				○	
Positive air shutdown system				○	
Flashing beacon			○	○	
Work lights: High output LED cab, boom, rear			○	○	
Road and work lights: High output LED front, cab, boom, rear			○	○	
Air-filled Enduro A/T tires		✓	✓	✓	
Foam-filled Enduro A/T tires			○	○	
Non-marking, foam-filled tires			○	○	
Solid rough terrain tires			○	○	
Lockable battery disconnect			○	○	
3-mode power steering (2-wheel, 4-wheel coordinated and crab)	✓	✓	✓		
Frame leveling +/- 10 degrees	✓	✓	✓		
Full time 4WD with front limited slip differential (LSD)	✓	✓	✓		
Internal multiple wet disc brakes	✓	✓	✓		
Rear axle stabilizing system	✓	✓	✓		
Spring applied, hydraulic release parking brake	✓	✓	✓		
Boom	Genie manual Quick-Attach (QA) system	✓	✓	✓	
	Auxiliary hydraulic circuit (15 GPM)	✓	✓	✓	
	Boom angle indicator	✓	✓	✓	
	Lifting shackle at boom tip	✓	✓	✓	
	Self-leveling fork frame	✓	✓	✓	

*Choose from either Open cab or Closed cab/ Heater only or AC and Heater

- S Standard
- S+ Standard +
- BtO Build to Order
- ✓ Standard Features
- Options



Side Mounted Engine



Lift Shackle



Long Life Tires



GTH Attachments

- Universal skid steer adapter (GTH-5519)
- QA Bucket .5cu.yd/0.38cu.m, 66in/1.67m (GTH-5519)
- QA Bucket 1cu.yd/0.76cu.m, 72in/1.82m (GTH-636, GTH-844)
- QA Bucket 1.5cu.yd/1.15cu.m, 96in/2.44m
- QA Carriage 48in/1.2m, 60in/1.5m, 72in/1.8m
- QA Fork positioner carriage 48in/1.2m
- QA Side shift carriage 48in/1.2m
- QA Side tilt rotating carr. 48in/1.2m, 60in/1.5m, 72in/1.8m
- QA Swing carriage 72in/1.8m
- QA Truss boom 8ft/2.44m Adjustable
- Cubing tines 48in (2x2x48in)/(.05x.05x1.2m) x 6
- Lumber forks 60in (1.75x7x60in)/(.04x.18x1.5m) x 2
- Pallet forks 48in (2x4x48in)/(.05x.1x1.2m) set of 2
- Pallet forks 60in (2x4x60in)/(.05x.1x1.5m) set of 2
- Pallet forks 72in (2x4x72in)/(.05x.1x1.8m) set of 2
- Pallet forks 96in (2x4x96in)/(.05x.1x2.4m) set of 2

Product specifications are subject to change without notice or obligation. Photographs and/or drawings herein are for illustrative purposes only. Refer to the appropriate Operator's Manual for instructions on proper equipment use. Failure to follow instructions in the Operator's Manual may result in serious injury or death. The only warranty applicable to our equipment is the standard written warranty applicable to the particular product and sale and we make no other warranty, express or implied. Products and services listed may be trademarks, service marks or trade names of Terex Corporation and/or their subsidiaries in the USA and many other countries. Terex, Genie, Quality By Design, Xtra Capacity, Lift Power, Lift Guard, Lift Tools, Lift Connect and Tech Pro Link are registered trademarks of Terex Corporation or its subsidiaries.

Genie® GTH™ -1044

Specifications

Models	GTH-1044	
Measurements	US	METRIC
Maximum lift height	44 ft 7 in	13.59 m
Maximum forward reach	30 ft 7 in	9.33 m
Reach at maximum height	4 ft 6 in	1.37 m
A Height, stowed	8 ft 5 in	2.57 m
B Length, stowed (without forks)	22 ft 2 in	6.76 m
Width	8 ft 6 in	2.59 m
C Wheelbase	11 ft 6 in	3.51 m
D Ground clearance, center	1 ft 3 in	0.38 m
E Ground clearance, axle	1 ft 6 in	0.46 m
Fork cross section	2×4 in	51×101 mm

Productivity

Maximum lift capacity	10,000 lb	4,536 kg
Lift capacity at maximum height	8,000 lb	3,629 kg
Lift capacity at maximum reach	4,000 lb	1,814 kg
Drive speed	18 mph	29 km/h
Boom up/down	13.12/11.23 sec	
Boom extend/retract	19.37/25.83 sec	
Draw bar pull	23,000 lb (74hp PS)	10,433 kg (74hp PS)
Frame leveling (side to side)	10°	
Turning radius, outside (4WS)	13 ft 11 in	4.24 m
Auxiliary hydraulic flow	2-15 gpm	7.6-56.8 lpm
Auxiliary hydraulic pressure	3,200 psi	220.6 bar
Tires, standard size	14×28 in	0.35×0.71 m

Power

Power source	Deutz TCD 3.6L4	
Electrical system voltage	12V	
Alternator	95 amp	
Battery	1000 CCA 0°F (-18°C)	
Hydraulic tank capacity	27 gal	102.2L
Hydraulic system capacity (w/tank)	52 gal	196.8L
Fuel tank capacity	30 gal	113.6L

Weight

Weight*	26,700 lb	12,111 kg
---------	-----------	-----------

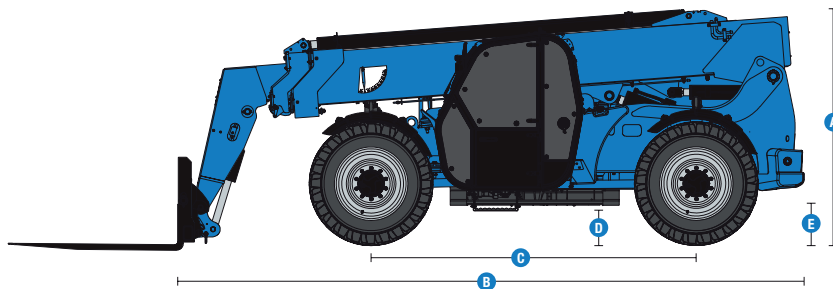

Range of motion GTH-1044 without stabilizers

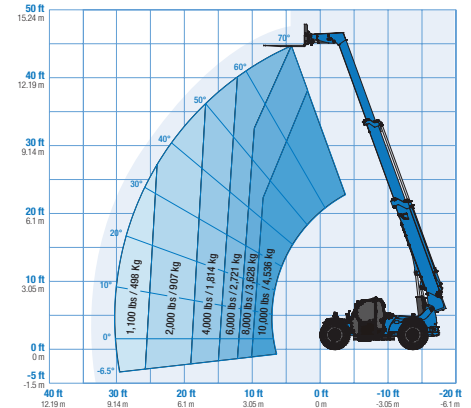

Range of motion GTH-1044 with stabilizers down

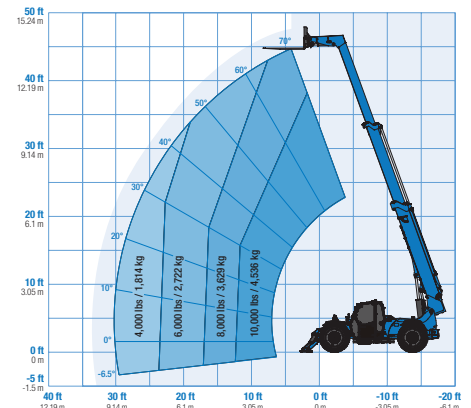

(1) Weight will vary depending on options and/or country standards.
 (2) Load ratings vary depending on attachment.

Genie® GTH™ -1044

SKU: Standard Model

- GTH10441AF0001:** GTH-1044, 74 hp, PS, No stabilizers, Open cab, FF Enduro A/T Tires
- GTH10441AF0002:** GTH-1044, 74 hp, PS, No stabilizers, Open cab, Solid Tires

* Build to Order

SKU: Standard Model

- GTH10441AF0003:** GTH-1044, 74 hp, PS, No stabilizers, Closed cab w/ AC and heater, FF Enduro A/T Tires
- GTH10441AF0004:** GTH-1044, 74 hp, PS, No stabilizers, Closed cab w/ AC and heater, Solid Tires

Option availability		S	S+	BtO	
Cab	Open cab*	✓	✓	✓	
	Closed cab*: Heater, defrost, wipers, washer, split door			○	
	Closed cab*: AC, heater, defrost, wipers, washer, split door	✓	✓	✓	
	Front and top glass			○	
	Lift Guard White Noise Alarm			○	
	Rear Proximity Alarm			○	
	Rear Proximity Alarm Ready			○	
	Rear proximity alarm with back-up camera and display			○	
	Fire extinguisher			○	
	3in/7.6cm high visibility red retractable seat belt	✓	✓	✓	
	Adjustable suspended seat	✓	✓	✓	
	Backup alarm	✓	✓	✓	
	Full gauge cluster with engine diagnostics	✓	✓	✓	
	Fully proportional hydraulic boom controls	✓	✓	✓	
	Machine level indicator	✓	✓	✓	
	Mirrors - LH canopy mounted and RH chassis mounted	✓	✓	✓	
	Multi-function joystick controller	✓	✓	✓	
	Chassis	74 hp, Deutz TCD 3.6, T4f, Side-mounted engine	✓	✓	✓
		Telematics-ready		○	○
		Lift Connect Telematics			○
Lift Connect with Access Manager upgrade				○	
Cold weather package				○	
Extreme cold weather package				○	
Fenders set of four				○	
Positive air shutdown system				○	
Flashing beacon			○	○	
Work lights: High output LED cab, boom, rear				○	
Road and work lights: High output LED front, cab, boom, rear			○	○	
Foam-filled Enduro A/T tires		✓	✓	✓	
Solid rough terrain tires		✓	✓	✓	
Air-filled Enduro A/T tires				○	
Non-marking, foam-filled Enduro A/T tires				○	
No stabilizers		✓	✓	✓	
Stabilizers, twin front mounted				○	
Lockable battery disconnect				○	
3-mode power steering (2-wheel, 4-wheel coordinated and crab)		✓	✓	✓	
Frame leveling +/- 10 degrees		✓	✓	✓	
Full time 4WD with front and rear limited slip differential (LSD)	✓	✓	✓		
Internal multiple wet disc brakes	✓	✓	✓		
Powershift transmission (PS) 3-speed 74 hp	✓	✓	✓		
Rear axle stabilizing system	✓	✓	✓		
Spring applied, hydraulic release parking brake	✓	✓	✓		
Tilt steering wheel	✓	✓	✓		
Boom	Genie manual Quick-Attach (QA) system	✓	✓	✓	
	Auxiliary hydraulic circuit (15 GPM)	✓	✓	✓	
	Boom angle indicator	✓	✓	✓	
	Lifting shackle at boom tip	✓	✓	✓	
	Self-leveling fork frame	✓	✓	✓	

*All our cabs are ROPS/FOPS canopy

- S Standard
- S+ Standard +
- BtO Build to Order
- ✓ Standard Features
- Options



74 HP No DEF Engine



Lift Shackle



Optional Stabilizers



GTH Attachments

- Universal skid steer adapter (GTH-5519)
- QA Bucket .5cu.yd/0.38cu.m, 66in/1.67m (GTH-5519)
- QA Bucket 1cu.yd/0.76cu.m, 72in/1.82m (GTH-636, GTH-844)
- QA Bucket 1.5cu.yd/1.15cu.m, 96in/2.44m
- QA Carriage 48in/1.2m, 60in/1.5m, 72in/1.8m
- QA Fork positioner carriage 48in/1.2m
- QA Side shift carriage 48in/1.2m
- QA Side tilt rotating carr. 48in/1.2m, 60in/1.5m, 72in/1.8m
- QA Swing carriage 72in/1.8m
- QA Truss boom 8ft/2.44m Adjustable
- Cubing tines 48in (2x2x48in)/(.05x.05x1.2m) x 6
- Lumber forks 60in (1.75x7x60in)/(.04x.18x1.5m) x 2
- Pallet forks 48in (2x4x48in)/(.05x.1x1.2m) set of 2
- Pallet forks 60in (2x4x60in)/(.05x.1x1.5m) set of 2
- Pallet forks 72in (2x4x72in)/(.05x.1x1.8m) set of 2
- Pallet forks 96in (2x4x96in)/(.05x.1x2.4m) set of 2

Product specifications are subject to change without notice or obligation. Photographs and/or drawings herein are for illustrative purposes only. Refer to the appropriate Operator's Manual for instructions on proper equipment use. Failure to follow instructions in the Operator's Manual may result in serious injury or death. The only warranty applicable to our equipment is the standard written warranty applicable to the particular product and sale and we make no other warranty, express or implied. Products and services listed may be trademarks, service marks or trade names of Terex Corporation and/or their subsidiaries in the USA and many other countries. Terex, Genie, Quality By Design, Xtra Capacity, Lift Power, Lift Guard, Lift Tools, Lift Connect and Tech Pro Link are registered trademarks of Terex Corporation or its subsidiaries.

Genie® GTH™ -1056

Specifications

Models	GTH-1056	
Measurements	US	METRIC
Maximum lift height	56 ft 7 in	17.25 m
Maximum forward reach	42 ft	12.80 m
A Height, stowed	8 ft 6 in	2.59 m
B Length, stowed (without forks)	22 ft 6 in	6.86 m
Width	8 ft 6 in	2.59 m
C Wheelbase	11 ft 6 in	3.50 m
D Ground clearance, center	1 ft 3 in	0.38 m
E Ground clearance, axle	1 ft 6 in	0.46 m
Fork cross section	2.25×4 in	57×101 mm
Productivity		
Maximum lift capacity	10,000 lb	4,536 kg
Lift capacity at maximum height	5,000 lb	2,268 kg
Lift capacity at maximum reach	3,000 lb	1,361 kg
Raise/Lower boom	15/12 sec	
Extend/Retract	23/30 sec	
Drive speed	15 mph (74hp PS) 18 mph (121hp PS)	24 km/h (74hp PS) 29 km/h (121hp PS)
Draw bar pull	23,000 lb (74hp PS) 25,000 lb (121hp PS)	10,433 kg (74hp PS) 11,340 kg (121hp PS)
Frame leveling (side to side)	10°	
Turning radius, outside (4WS)	14 ft	4.27 m
Auxiliary hydraulic flow	2-15 gpm	7.6-56.8 lpm
Auxiliary hydraulic pressure	3,170 psi	220 bar
Tires, standard size	Genie Enduro A/T 400/75-28	
Power		
Power source	Deutz TCD 3.6	
Electrical system voltage	12V	
Alternator	95 amp	
Battery	1000 CCA 0°F (-18°C)	
Hydraulic tank capacity	27 gal	102.2L
Hydraulic system capacity (w/tank)	52 gal	189.2L
Fuel tank capacity	30 gal	113.6L
Weight		
Weight*	31,900 lb	14,470 kg

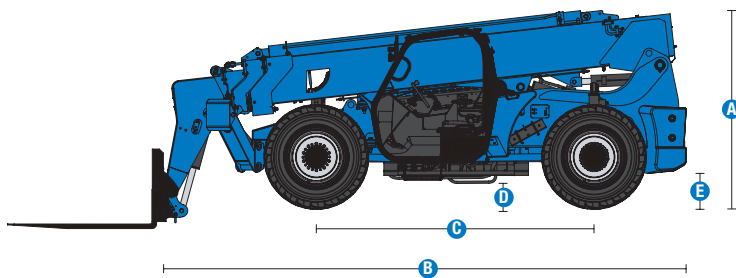

Range of motion GTH-1056 with stabilizers up

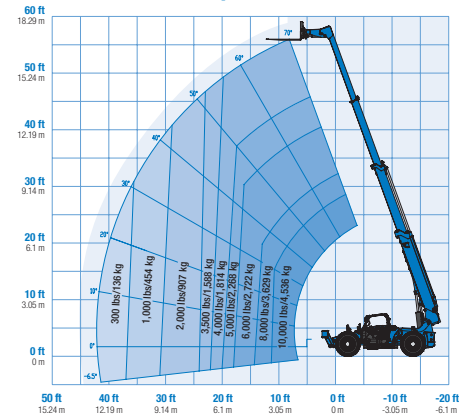

Range of motion GTH-1056 with stabilizers down

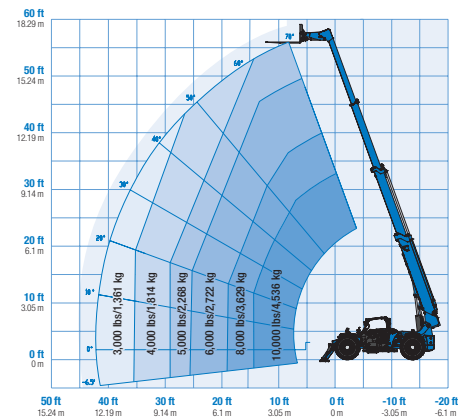

(1) Weight will vary depending on options and/or country standards.
 (2) Load ratings vary depending on attachment.

Genie® GTH™ -1056

SKU: Standard Model

- **GTH10561AF0148:** GTH-1056, 74 hp, PS, Open cab
 - **GTH10561AF0148:** GTH-1056, 121 hp, PS, Open cab
- * Build to Order

SKU: Standard Model

- **GTH10561AF0145:** GTH-1056, 74 hp, PS, Closed cab w/ AC and heater, road and work lights, flashing beacon
- **GTH10561AF0147:** GTH-1056, 121 hp, PS, Closed cab w/ AC and heater, road and work lights, flashing beacon

Option availability	S	S+	BtO
Cab			
Cab ROPS/FOPS canopy*	✓	✓	✓
Closed cab: Heater, defrost, wipers, washer, split door*	✓	✓	✓
Closed cab: AC, heater, defrost, wipers, washer, split door*	✓	✓	✓
Front and top glass		○	○
Lift Guard White Noise Alarm		○	○
Rear Proximity Alarm		○	○
Rear proximity alarm with back-up camera and display		○	○
Fire extinguisher		○	○
3in/7.6cm high visibility red retractable seat belt	✓	✓	✓
Adjustable suspended seat	✓	✓	✓
Backup alarm	✓	✓	✓
Full gauge cluster with engine diagnostics	✓	✓	✓
Fully proportional hydraulic boom controls	✓	✓	✓
Machine level indicator	✓	✓	✓
Mirrors - LH canopy mounted and RH chassis mounted	✓	✓	✓
Multi-function joystick controller	✓	✓	✓
Chassis			
74 hp, Deutz TCD 3.6, T4f, Side-mounted engine	✓	✓	✓
121 hp, Deutz TCD 3.6, T4f, Side-mounted engine			○
Powershift transmission (PS) 3-speed 74 hp	✓	✓	○
Powershift transmission (PS) 4-speed 121 hp			○
Telematics-ready	✓	✓	✓
Lift Connect Telematics		○	○
Lift Connect with Access Manager upgrade		○	○
Extreme cold weather package			○
Fenders set of four		○	○
Lojack stolen vehicle recovery system			○
Positive air shutdown system			○
Flashing beacon		○	○
Work lights: High output LED cab, boom, rear		○	○
Road and work lights: High output LED front, cab, boom, rear		○	○
Air-filled Enduro A/T tires		○	○
Foam-filled Enduro A/T tires	✓	✓	✓
Non-marking, foam-filled tires		○	○
Solid rough terrain tires		○	○
Stabilizers, twin front mounted	✓	✓	✓
Lockable battery disconnect		○	○
3-mode power steering (2-wheel, 4-wheel coordinated and crab)	✓	✓	✓
Frame leveling +/- 10 degrees	✓	✓	✓
Full time 4WD with front and rear limited slip differential (LSD)	✓	✓	✓
Internal multiple wet disc brakes	✓	✓	✓
Rear axle stabilizing system	✓	✓	✓
Spring applied, hydraulic release parking brake	✓	✓	✓
Tilt steering wheel	✓	✓	✓
Boom			
Genie manual Quick-Attach (QA) system	✓	✓	✓
Auxiliary hydraulic circuit (15 GPM)	✓	✓	✓
Boom angle indicator	✓	✓	✓
Lifting shackle at boom tip	✓	✓	✓
Self-leveling fork frame	✓	✓	✓

*Choose from either Open cab or Closed cab/ Heater only or AC and Heater

- S Standard
- S+ Standard +
- BtO Build to Order
- ✓ Standard Features
- Options



Side Mounted Engine



Lift Shackle



Long Life Tires



GTH Attachments

- Universal skid steer adapter (GTH-5519)
- QA Bucket .5cu.yd/0.38cu.m, 66in/1.67m (GTH-5519)
- QA Bucket 1cu.yd/0.76cu.m, 72in/1.82m (GTH-636, GTH-844)
- QA Bucket 1.5cu.yd/1.15cu.m, 96in/2.44m
- QA Carriage 48in/1.2m, 60in/1.5m, 72in/1.8m
- QA Fork positioner carriage 48in/1.2m
- QA Side shift carriage 48in/1.2m
- QA Side tilt rotating carr. 48in/1.2m, 60in/1.5m, 72in/1.8m
- QA Swing carriage 72in/1.8m
- QA Truss boom 8ft/2.44m Adjustable
- Cubing tines 48in (2x2x48in)/(.05x.05x1.2m) x 6
- Lumber forks 60in (1.75x7x60in)/(.04x.18x1.5m) x 2
- Pallet forks 48in (2x4x48in)/(.05x.1x1.2m) set of 2
- Pallet forks 60in (2x4x60in)/(.05x.1x1.5m) set of 2
- Pallet forks 72in (2x4x72in)/(.05x.1x1.8m) set of 2
- Pallet forks 96in (2x4x96in)/(.05x.1x2.4m) set of 2

Product specifications are subject to change without notice or obligation. Photographs and/or drawings herein are for illustrative purposes only. Refer to the appropriate Operator's Manual for instructions on proper equipment use. Failure to follow instructions in the Operator's Manual may result in serious injury or death. The only warranty applicable to our equipment is the standard written warranty applicable to the particular product and sale and we make no other warranty, express or implied. Products and services listed may be trademarks, service marks or trade names of Terex Corporation and/or their subsidiaries in the USA and many other countries. Terex, Genie, Quality By Design, Xtra Capacity, Lift Power, Lift Guard, Lift Tools, Lift Connect and Tech Pro Link are registered trademarks of Terex Corporation or its subsidiaries.

Genie® GTH™ -1244

Specifications

Models	GTH-1244	
Measurements	US	METRIC
Maximum lift height	44 ft 7 in	13.59 m
Maximum forward reach	30 ft 7 in	9.33 m
Reach at maximum height	4 ft 6 in	1.37 m
A Height, stowed	8 ft 5 in	2.57 m
B Length, stowed (without forks)	22 ft 2 in	6.76 m
Width	8 ft 6 in	2.59 m
C Wheelbase	11 ft 6 in	3.51 m
D Ground clearance, center	1 ft 3 in	0.38 m
E Ground clearance, axle	1 ft 6 in	0.46 m
Fork cross section	2x4 in	51x101 mm

Productivity

Maximum lift capacity	12,000 lb	5,443 kg
Lift capacity at maximum height	8,000 lb	3,629 kg
Lift capacity at maximum reach	4,000 lb	1,814 kg
Drive speed	18 mph	29 km/h
Boom up/down	14.9/13.6 sec	
Boom extend/retract	21/25 sec	
Draw bar pull	23,000 lb (74hp PS)	10,433 kg (74hp PS)
	25,000 lb (121hp PS)	11,340 kg (121hp PS)
Frame leveling (side to side)	10°	
Turning radius, outside (4WS)	13 ft 11 in	4.24 m
Auxiliary hydraulic flow	2-15 gpm	7.6-56.8 lpm
Auxiliary hydraulic pressure	3,200 psi	220.6 bar
Tires, standard size	14x28 in	0.35x0.71 m

Power

Power source	Deutz TCD 3.6 L4	
Electrical system voltage	12V	
Alternator	95 amp	
Battery	1000 CCA 0°F (-18°C)	
Hydraulic tank capacity	27 gal	102.2L
Hydraulic system capacity (w/tank)	52 gal	196.8L
Fuel tank capacity	30 gal	113.6L

Weight

Weight*	28,900 lb	13,109 kg
---------	-----------	-----------

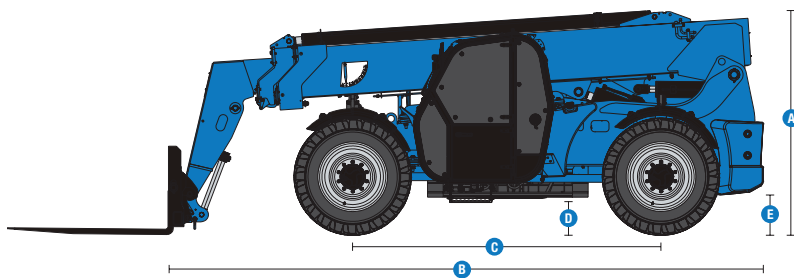

Range of motion GTH-1244 without stabilizers

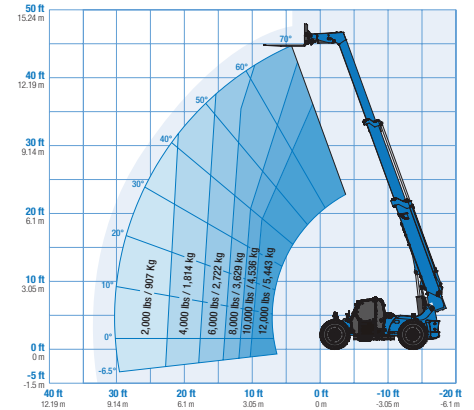

Range of motion GTH-1244 with stabilizers down

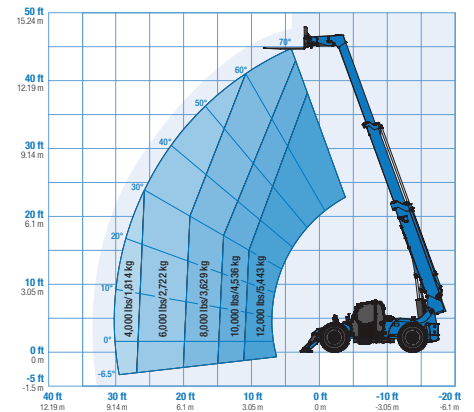

(1) Weight will vary depending on options and/or country standards.
 (2) Load ratings vary depending on attachment.

Genie® GTH™ -1244

SKU: Standard Model

- **GTH12441AF0001:** GTH-1244, 74 hp, PS, No stabilizers, Open cab, FF Enduro A/T Tires
- **GTH12441AF0003:** GTH-1244, 74 hp, PS, No stabilizers, Closed cab w/ AC and heater, FF Enduro A/T Tires
- **GTH12441AF0004:** GTH-1244, 74 hp, PS, No stabilizers, Closed cab w/ AC and heater, Solid Tires

SKU: Standard Model

- **GTH12441AF0002:** GTH-1244, 74 hp, PS, No stabilizers, Open cab, Solid Tires
- GTH-1244, 121 hp, PS, No stabilizers, Open cab*
- GTH-1244, 121 hp, PS, No stabilizers, Closed cab*

* Build to Order

Option availability		S	S+	BtO
Cab	Open cab*	✓	✓	✓
	Closed cab*: Heater, defrost, wipers, washer, split door			○
	Closed cab*: AC, heater, defrost, wipers, washer, split door	✓	✓	✓
	Front and top glass			○
	Lift Guard White Noise Alarm			○
	Rear Proximity Alarm			○
	Rear Proximity Alarm Ready			○
	Rear proximity alarm with back-up camera and display			○
	Fire extinguisher			○
	3in/7.6cm high visibility red retractable seat belt	✓	✓	✓
	Adjustable suspended seat	✓	✓	✓
	Backup alarm	✓	✓	✓
	Full gauge cluster with engine diagnostics	✓	✓	✓
	Fully proportional hydraulic boom controls	✓	✓	✓
	Machine level indicator	✓	✓	✓
	Mirrors - LH canopy mounted and RH chassis mounted	✓	✓	✓
	Multi-function joystick controller	✓	✓	✓
	Chassis	121 hp, Deutz TCD 3.6, T4f, Side-mounted engine		
74 hp, Deutz TCD 3.6, T4f, Side-mounted engine		✓	✓	✓
Powershift transmission (PS) 3-speed 74 hp		✓	✓	✓
Powershift transmission (PS) 4-speed 121 hp				○
Telematics-ready			○	○
Lift Connect Telematics				○
Lift Connect with Access Manager upgrade				○
Cold weather package				○
Extreme cold weather package				○
Fenders set of four				○
Positive air shutdown system				○
Flashing beacon			○	○
Work lights: High output LED cab, boom, rear				○
Road and work lights: High output LED front, cab, boom, rear			○	○
Foam-filled Enduro A/T tires		✓	✓	✓
Solid rough terrain tires		✓	✓	✓
Air-filled Enduro A/T tires				○
No stabilizers		✓	✓	✓
Stabilizers, twin front mounted				○
Lockable battery disconnect				○
3-mode power steering (2-wheel, 4-wheel coordinated and crab)	✓	✓	✓	
Frame leveling +/- 10 degrees	✓	✓	✓	
Full time 4WD with front and rear limited slip differential (LSD)	✓	✓	✓	
Internal multiple wet disc brakes	✓	✓	✓	
Rear axle stabilizing system	✓	✓	✓	
Spring applied, hydraulic release parking brake	✓	✓	✓	
Tilt steering wheel	✓	✓	✓	
Boom	Genie manual Quick-Attach (QA) system	✓	✓	✓
	Auxiliary hydraulic circuit (15 GPM)	✓	✓	✓
	Boom angle indicator	✓	✓	✓
	Lifting shackle at boom tip	✓	✓	✓
	Self-leveling fork frame	✓	✓	✓

*All our cabs are ROPS/FOPS canopy

Product specifications are subject to change without notice or obligation. Photographs and/or drawings herein are for illustrative purposes only. Refer to the appropriate Operator's Manual for instructions on proper equipment use. Failure to follow instructions in the Operator's Manual may result in serious injury or death. The only warranty applicable to our equipment is the standard written warranty applicable to the particular product and sale and we make no other warranty, express or implied. Products and services listed may be trademarks, service marks or trade names of Terex Corporation and/or their subsidiaries in the USA and many other countries. Terex, Genie, Quality By Design, Xtra Capacity, Lift Power, Lift Guard, Lift Tools, Lift Connect and Tech Pro Link are registered trademarks of Terex Corporation or its subsidiaries.

02/25

- S Standard
- S+ Standard +
- BtO Build to Order
- ✓ Standard Features
- Options



74 HP No DEF Engine



Lift Shackle



Optional Stabilizers



GTH Attachments

- Universal skid steer adapter (GTH-5519)
- QA Bucket .5cu.yd/0.38cu.m, 66in/1.67m (GTH-5519)
- QA Bucket 1cu.yd/0.76cu.m, 72in/1.82m (GTH-636, GTH-844)
- QA Bucket 1.5cu.yd/1.15cu.m, 96in/2.44m
- QA Carriage 48in/1.2m, 60in/1.5m, 72in/1.8m
- QA Fork positioner carriage 48in/1.2m
- QA Side shift carriage 48in/1.2m
- QA Side tilt rotating carr. 48in/1.2m, 60in/1.5m, 72in/1.8m
- QA Swing carriage 72in/1.8m
- QA Truss boom 8ft/2.44m Adjustable
- Cubing tines 48in (2x2x48in)/(.05x.05x1.2m) x 6
- Lumber forks 60in (1.75x7x60in)/(.04x.18x1.5m) x 2
- Pallet forks 48in (2x4x48in)/(.05x.1x1.2m) set of 2
- Pallet forks 60in (2x4x60in)/(.05x.1x1.5m) set of 2
- Pallet forks 72in (2x4x72in)/(.05x.1x1.8m) set of 2
- Pallet forks 96in (2x4x96in)/(.05x.1x2.4m) set of 2

Genie® GTH™ -1256

Specifications

Models	GTH-1256	
Measurements	US	METRIC
Maximum lift height	56 ft 3 in	17.15 m
Maximum forward reach	42 ft	12.80 m
Reach at maximum height	7 ft 11 in	2.41 m
A Height, stowed	8 ft 8 in	2.63 m
B Length, stowed (without forks)	22 ft 8 in	6.91 m
Width	8 ft 6 in	2.59 m
C Wheelbase	11 ft 6 in	3.51 m
D Ground clearance, center	1 ft 3 in	0.38 m
E Ground clearance, axle	1 ft 6 in	0.46 m
Fork cross section	2.4×4 in	61×99 mm

Productivity

Maximum lift capacity	12,000 lb	5,443 kg
Lift capacity at maximum height	6,000 lb	2,721 kg
Lift capacity at maximum reach	3,500 lb	1,588 kg
Raise/Lower boom	20/17 sec	
Extend/Retract	35/28.5 sec	
Drive speed	17 mph (121hp PS)	27 km/h (121hp PS)
Draw bar pull	25,000 lb (121hp PS)	11,340 kg (121hp PS)
Frame leveling (side to side)	10°	
Turning radius, outside (4WS)	14 ft 3 in	4.34 m
Auxiliary hydraulic flow	2-15 gpm	7.57-56.8 lpm
Auxiliary hydraulic pressure	3,200 psi	220.6 bar
Tires, standard size	Genie Enduro A/T 400/75-28	

Power

Power source	Deutz TCD 3.6	
Electrical system voltage	12V	
Alternator	95 amp	
Battery	1000 CCA 0°F (-18°C)	
Hydraulic tank capacity	27 gal	102.2L
Hydraulic system capacity (w/tank)	52 gal	196.8L
Fuel tank capacity	30 gal	113.6L

Weight

Weight*	34,500 lb	15,649 kg
---------	-----------	-----------

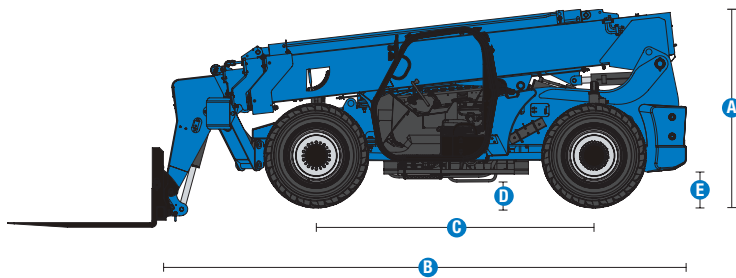

Range of motion GTH-1256 with stabilizers up

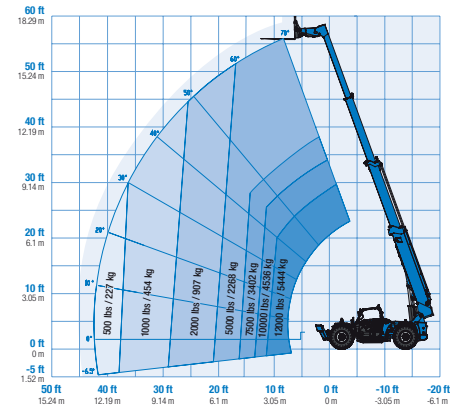

Range of motion GTH-1256 with stabilizers down

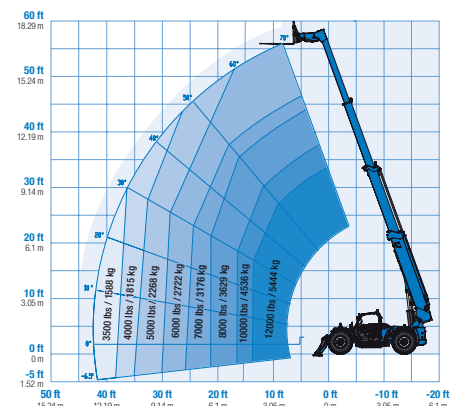

(1) Weight will vary depending on options and/or country standards.
 (2) Load ratings vary depending on attachment.

Genie® GTH™ -1256

SKU: Standard Model

- **GTH12561AF0024:** GTH-1256, 121 hp, PS, Open cab

* Build to Order

SKU: Standard Model

- **GTH12561AF0025:** GTH-1256, 121 hp, PS, Closed cab w/ AC and heater, road and work lights, flashing beacon

Option availability		S	S+	BtO
Cab	Cab ROPS/FOPS canopy*	✓	✓	✓
	Closed cab: Heater, defrost, wipers, washer, split door*	✓	✓	✓
	Closed cab: AC, heater, defrost, wipers, washer, split door*	✓	✓	✓
	Front and top glass		○	○
	Lift Guard White Noise Alarm			○
	Rear Proximity Alarm		○	○
	Rear proximity alarm with back-up camera and display		○	○
	Fire extinguisher		○	○
	3in/7.6cm high visibility red retractable seat belt	✓	✓	✓
	Adjustable suspended seat	✓	✓	✓
	Backup alarm	✓	✓	✓
	Full gauge cluster with engine diagnostics	✓	✓	✓
	Fully proportional hydraulic boom controls	✓	✓	✓
	Machine level indicator	✓	✓	✓
	Mirrors - LH canopy mounted and RH chassis mounted	✓	✓	✓
	Multi-function joystick controller	✓	✓	✓
	Chassis	121 hp, Deutz TCD 3.6, T4f, Side-mounted engine	✓	✓
Powershift transmission (PS) 4-speed 121 hp		✓	✓	✓
Telematics-ready		✓	○	○
Lift Connect Telematics			○	○
Lift Connect with Access Manager upgrade			○	○
Cold weather package				○
Fenders set of four			○	○
Lojack stolen vehicle recovery system				○
Positive air shutdown system				○
Flashing beacon			○	○
Work lights: High output LED cab, boom, rear			○	○
Road and work lights: High output LED front, cab, boom, rear			○	○
Air-filled Enduro A/T tires			○	○
Foam-filled Enduro A/T tires		✓	○	○
Solid rough terrain tires			○	○
Stabilizers, twin front mounted		✓	✓	✓
Lockable battery disconnect			○	○
3-mode power steering (2-wheel, 4-wheel coordinated and crab)		✓	✓	✓
Frame leveling +/- 10 degrees		✓	✓	✓
Full time 4WD with front and rear limited slip differential (LSD)		✓	✓	✓
Internal multiple wet disc brakes	✓	✓	✓	
Rear axle stabilizing system	✓	✓	✓	
Spring applied, hydraulic release parking brake	✓	✓	✓	
Tilt steering wheel	✓	✓	✓	
Boom	Genie manual Quick-Attach (QA) system	✓	✓	✓
	Auxiliary hydraulic circuit (15 GPM)	✓	✓	✓
	Boom angle indicator	✓	✓	✓
	Lifting shackle at boom tip	✓	✓	✓
	Self-leveling fork frame	✓	✓	✓

*Choose from either Open cab or Closed cab/ Heater only or AC and Heater

- S Standard
- S+ Standard +
- BtO Build to Order
- ✓ Standard Features
- Options



Side Mounted Engine



Lift Shackle



Long Life Tires



GTH Attachments

- Universal skid steer adapter (GTH-5519)
- QA Bucket .5cu.yd/0.38cu.m, 66in/1.67m (GTH-5519)
- QA Bucket 1cu.yd/0.76cu.m, 72in/1.82m (GTH-636, GTH-844)
- QA Bucket 1.5cu.yd/1.15cu.m, 96in/2.44m
- QA Carriage 48in/1.2m, 60in/1.5m, 72in/1.8m
- QA Fork positioner carriage 48in/1.2m
- QA Side shift carriage 48in/1.2m
- QA Side tilt rotating carr. 48in/1.2m, 60in/1.5m, 72in/1.8m
- QA Swing carriage 72in/1.8m
- QA Truss boom 8ft/2.44m Adjustable
- Cubing tines 48in (2x2x48in)/(.05x.05x1.2m) x 6
- Lumber forks 60in (1.75x7x60in)/(.04x.18x1.5m) x 2
- Pallet forks 48in (2x4x48in)/(.05x.1x1.2m) set of 2
- Pallet forks 60in (2x4x60in)/(.05x.1x1.5m) set of 2
- Pallet forks 72in (2x4x72in)/(.05x.1x1.8m) set of 2
- Pallet forks 96in (2x4x96in)/(.05x.1x2.4m) set of 2

Product specifications are subject to change without notice or obligation. Photographs and/or drawings herein are for illustrative purposes only. Refer to the appropriate Operator's Manual for instructions on proper equipment use. Failure to follow instructions in the Operator's Manual may result in serious injury or death. The only warranty applicable to our equipment is the standard written warranty applicable to the particular product and sale and we make no other warranty, express or implied. Products and services listed may be trademarks, service marks or trade names of Terex Corporation and/or their subsidiaries in the USA and many other countries. Terex, Genie, Quality By Design, Xtra Capacity, Lift Power, Lift Guard, Lift Tools, Lift Connect and Tech Pro Link are registered trademarks of Terex Corporation or its subsidiaries.



Genie®

20021 120th Ave NE, Bothell, WA 98011

TOLL FREE IN USA/CANADA +1 (800) 536-1800 . TELEPHONE +1 (425) 881-1800 . FAX +1 (425) 883-3475

www.genielift.com

Worldwide Manufacturing And Distribution

For our full list of locations, go to www.genielift.com

Effective Date: March, 2025. Product specifications and prices are subject to change without notice or obligation. The photographs and/or drawings in this document are for illustrative purposes only. Refer to the appropriate Operator's Manual for instructions on the proper use of this equipment. Failure to follow the appropriate Operator's Manual when using our equipment or to otherwise act irresponsibly may result in serious injury or death. The only warranty applicable to our equipment is the standard written warranty applicable to the particular product and sale and we make no other warranty, express or implied. Products and services listed may be trademarks, service marks or trade names of Terex Corporation and/or their subsidiaries in the USA and many other countries. © 2025 Terex Corporation. Genie is a trademark of Terex Corporation or its subsidiaries. GPB 3K 0109M. Part No. 793690.

